

TOP VIEW (COVER NOT SHOWN)

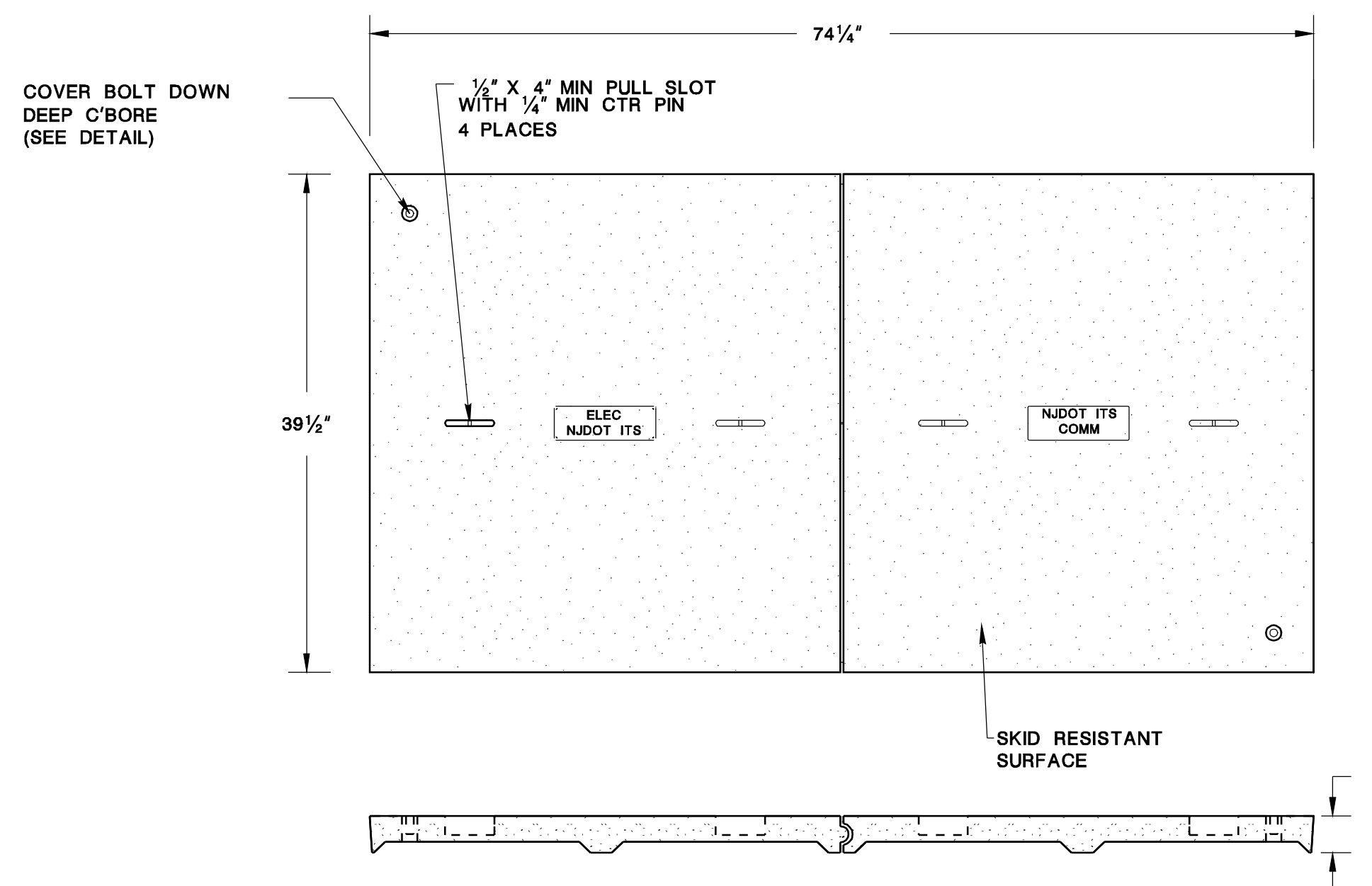

COVER

**NOTES:**

1. ENSURE THE COVER IS FASTENED TO THE BOX WITH TWO (2) 1/2" -13NC STAINLESS STEEL HEX BOLTS, LOCATED AT OPPOSITE CORNERS OF THE COVER. ENSURE BOLTS ARE CAPTIVE TO LID.
2. ENSURE THE COVER SURFACE IS SKID RESISTANT WITH A COEFFICIENT OF FRICTION OF AT LEAST 0.5.
3. ENSURE THE DESIGN AND FABRICATION OF THE BOX AND COVER CONFORMS TO ALL ASPECTS OF ANSI/SCTE 77. ENSURE LOADING IS TIER 22.
4. ENSURE THE JUNCTION BOX IS PRECAST POLYMER CONCRETE. ENSURE THE COVER IS MADE OF FIBER GLASS REINFORCED POLYMER CONCRETE.
5. ENSURE THE COLOR OF THE COVER AND ANY PART OF THE BOX VISIBLE WHEN IT IS INSTALLED, IS "CONCRETE GREY."
6. ENSURE THE IDENTIFICATION OF THE COVER IS PERMANENTLY MOLDED ON THE TOP SURFACE WITH "NJDOT ITS".
7. UNLESS OTHERWISE DIRECTED BY THE ENGINEER ALL CONDUIT ENTRANCES INTO THE JUNCTION BOX ARE TO BE FIELD DRILLED WITH A HOLE SAW OR PUNCHED OUT USING A HYDRAULIC HOLE PUNCH.
8. ALL CONDUIT OPENINGS MUST BE SANDED. AFTER THE CONDUITS ARE INSTALLED, ALL CONDUIT ENTRANCES MUST BE SEALED WITH AN EPOXY PUTTY OR SILICON CAULK.
9. IN GRASS OR DIRT AREAS, A CONCRETE PAD, CLASS "C", MUST BE POURED AROUND THE TOP OF THE JUNCTION BOX.
10. COMPACTED 3/4" GRAVEL OR BROKEN STONE IS REQUIRED BELOW THE BOX. SUPPLY AN ADDITIONAL SIX (6) INCHES OF TIGHTLY COMPACTED 3/4" CLEAN STONE PLACED IN BOTTOM OF BOX.
11. PROVIDE A CONCRETE LOCK-IN FEATURE AT THE TOP OF THE BOX. ACTUAL DESIGN CAN VARY PER MANUFACTURER.
12. ENSURE THE GAP FROM THE EDGE OF THE COVER TO THE INSIDE EDGE OF THE BOX IS A MAXIMUM OF 1/8" +/- 1/16".
13. ENSURE THE TOP OF THE POLYMER CONCRETE COVER IS SET FLUSH WITH THE TOP OF THE JUNCTION BOX.
14. PROVIDE CERTIFICATION BY A PROFESSIONAL ENGINEER OF TEST RESULTS SHOWING THAT THE JUNCTION BOX AND COVER MEET THE DESIGN SPECIFIED LOADING REQUIREMENTS.
15. UTILIZE BOX EXTENSION TO PROVIDE REQUIRED DEPTH.
16. SUPPLY BOX WITH CABLE RACK SYSTEMS AFFIXED TO BOTH LONG SIDES OF THE BOX FOR STORAGE OF CABLE SLACK.
17. THE BOX MUST MEET REQUIREMENTS OF NEC ARTICLE 314.
18. ALL EXPOSED HARDWARE TO BE STAINLESS STEEL.
19. DIMENSIONS ARE TYPICAL. ENSURE CUT SHEETS ARE SUBMITTED FOR APPROVAL FOR THE EXACT BOX TO BE UTILIZED. THE BOX IS TO HAVE AN OPEN BOTTOM.

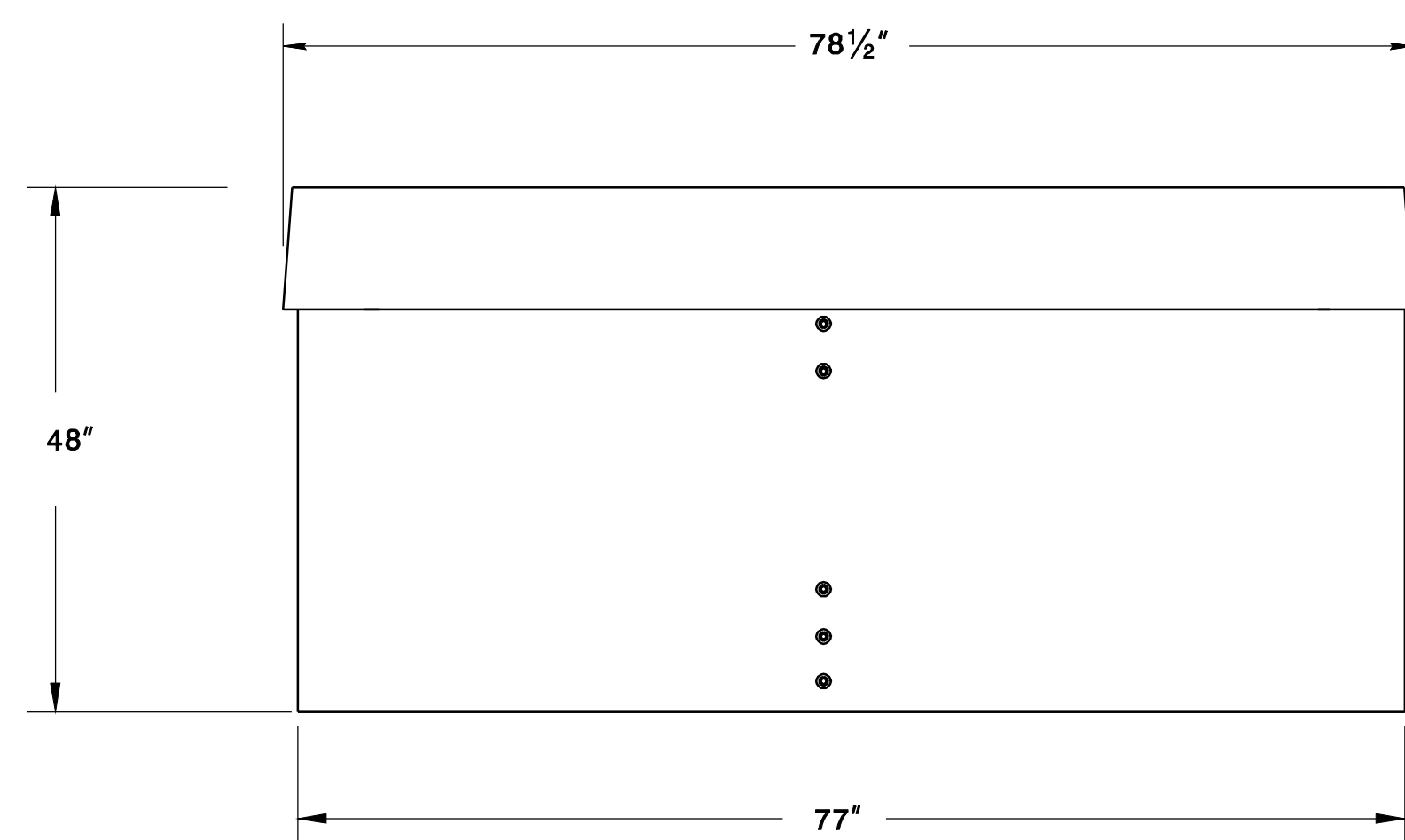

ELEVATION

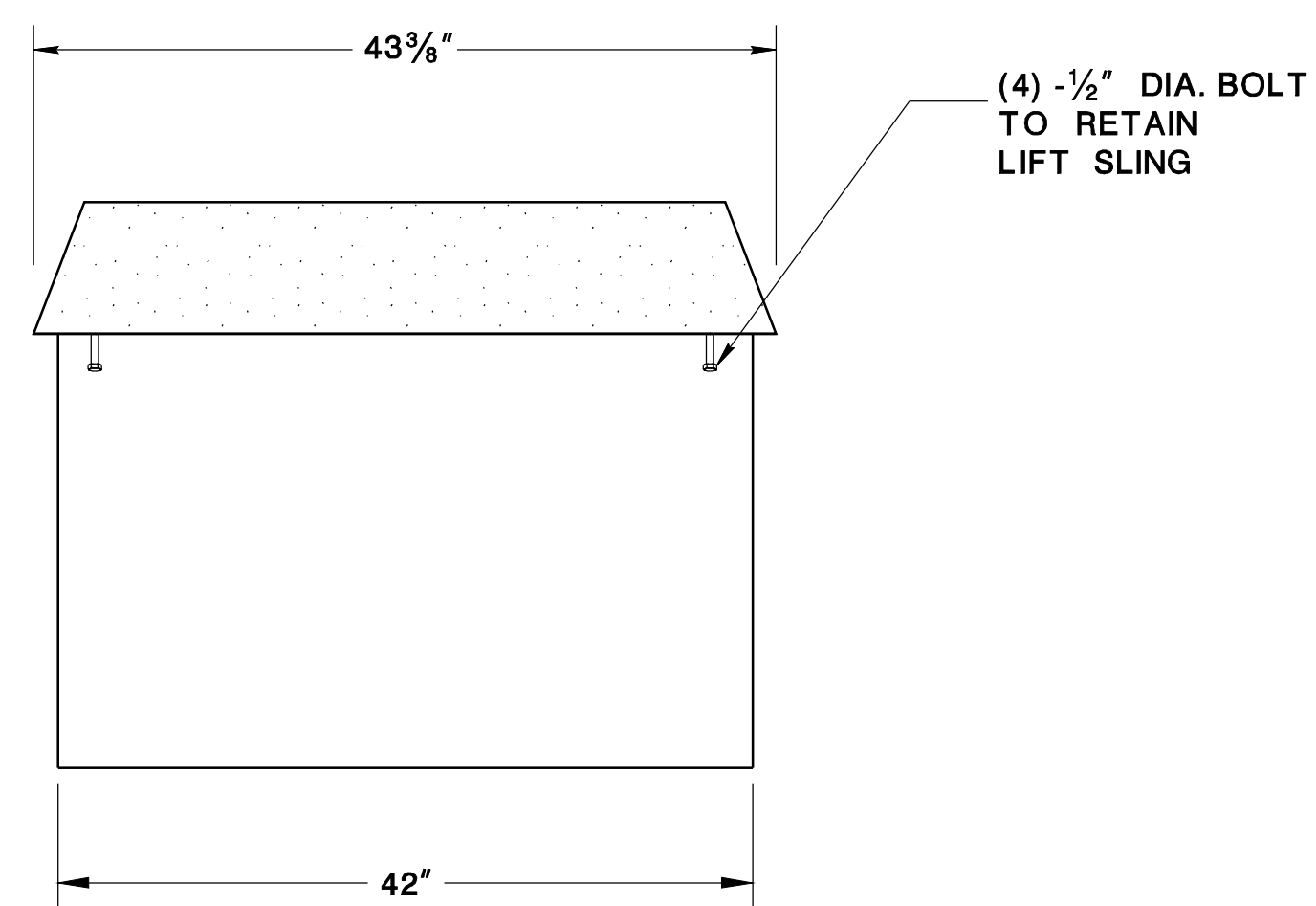

SIDE VIEW

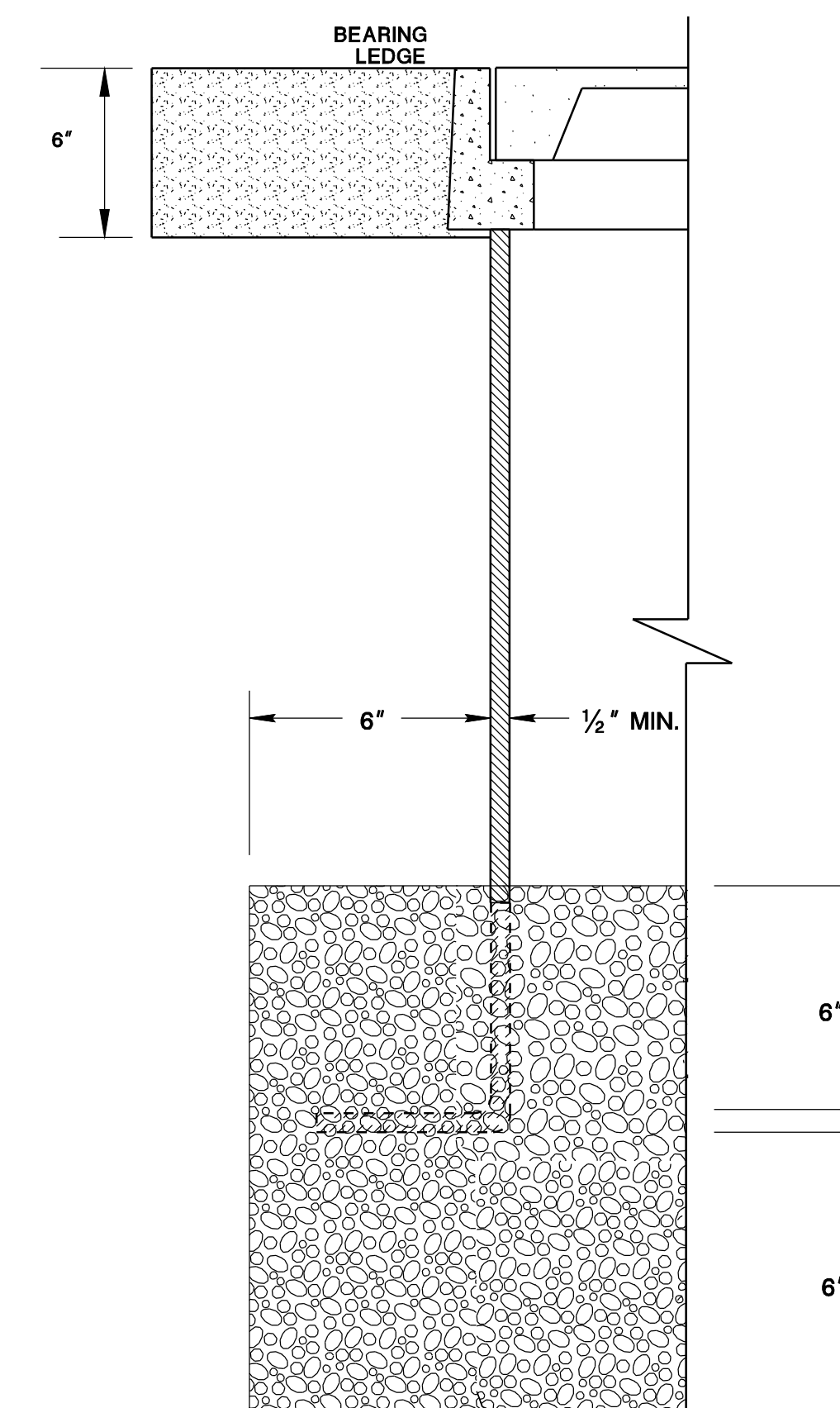

SECTION A-A

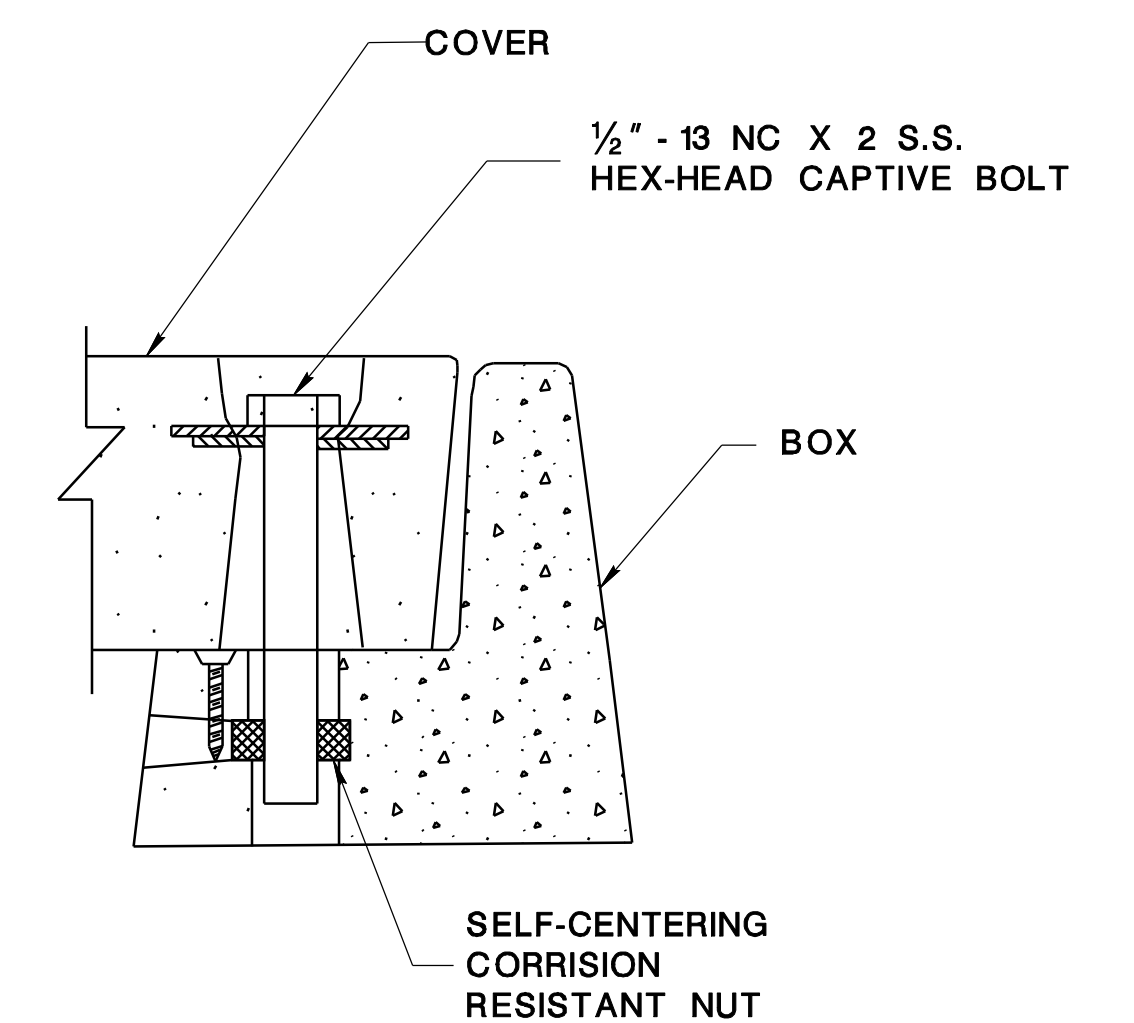

COVER BOLT DOWN DETAIL

NOT TO SCALE

ITS-704-10

NEW JERSEY DEPARTMENT OF TRANSPORTATION

**ITS DETAILS**  
JUNCTION BOX ITS TYPE D

