

State of New Jersey
Department of Transportation

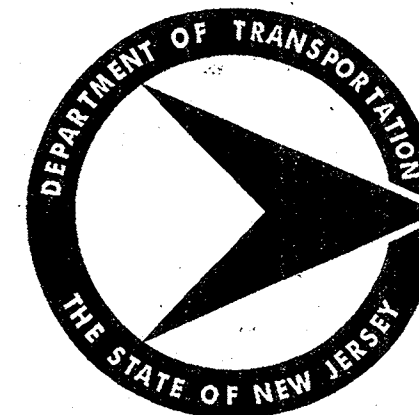

STANDARD ROADWAY CONSTRUCTION –
TRAFFIC CONTROL – BRIDGE CONSTRUCTION
DETAILS
2001

(U.S. Customary English Units)



Baseline Document Change Announcement

Standard Roadway Construction - Traffic Control - Bridge Construction Details Booklet, 2001 English Units

BDC00D-1

August 24, 2001

Subject: Release of the Standard Roadway Construction - Traffic Control - Bridge Construction Details Booklet, 2001, in U.S. Customary English Units.

This Release of the Standard Roadway Construction - Traffic Control - Bridge Construction Details Booklet, 2001, in U.S. Customary English Units is a continuation of the Department's conversion of engineering documents from metric to English units.

The details in the attached booklet are similar in content to the metric 1996 Standard Roadway Construction - Traffic Control - Bridge Construction Details Booklet issued under BDC96D-001 dated October 25, 1996. The differences between the new booklet and the 1996 metric booklet are indicated below.

General:

- All the dimensions, with one exception, have been converted from metric to U.S. Customary English Units. The exception is due to the steel industry producing and marking/designating reinforcing bars in metric units only. Therefore, all reinforcing bar sizes indicated on the details are in metric units. The note "REINFORCING BARS ARE IN METRIC UNITS.", has been added on all sheets that include reinforcing bars.
- The attached booklet has been updated to include the following construction details that were issued via BDC Announcements subsequent to the 1996 booklet:
 - BDC98D-001 dated 02/16/99
 - BDC98D-005 dated 10/09/98
 - BDC98D-004 dated 08/20/98
 - BDC97D-004 dated 05/28/98
 - BDC97D-003 dated 06/04/98
 - BDC97DS-001 dated 03/18/99
 - BDC98DS-001 dated 02/11/99
- The revisions include corrections to spelling, grammar and drafting errors, as well as changes to sequencing of notes and the removal of redundant information. In some cases notes have been added to clarify intent.
- All known details, which are no longer used, have been eliminated.
- The detail booklet is produced in half scale for convenience. For legibility, the font and general presentation has been enhanced.
- The note N.T.S., "Not to Scale", was indicated on each sub-detail in the 1996 booklet. However, the N.T.S. is indicated only once on each sheet, above the title block.
- The details indicating "white concrete" as the concrete for curb and sidewalk have been revised to allow both gray and white colors by stating "concrete/white concrete" in the detail title and changing the reference "white concrete, class B" to "concrete class B".

New Jersey Is An Equal Opportunity Employer • Printed on Recycled and Recyclable Paper

- The TCDs that included letters in the sheet designation, such as TCD-14A and TCD-14B have been renumbered to eliminate the letter suffixes.
- References to bituminous concrete have been changed to Hot Mix Asphalt. This was accomplished by replacing the words "bituminous concrete" with "HMA" throughout the details and indicating HMA = HOT MIX ASPHALT in the vicinity of the title block on every sheet that the material is shown.
- The Table of Contents has been revised to include the title of each construction detail sheet.

Specific Changes:

- CD-306-1, Contraction Joints in Concrete Base Course
The previous CD-306-1 was outdated. Therefore, the detail has been revised to be consistent with current construction practices
- CD-405-1, Concrete Surface Course
This detail has been revised to clarify the application of options for thickness of slabs and type of reinforcement.
- CD-602-1, Pipe End Sections
The dimensions of the various sizes of pipe end sections indicated on the previous details were not consistent with what is currently manufactured. Therefore, the details have been revised to the current manufactured dimensions. In addition, the "dimension chart" has been revised to include only the dimensions that are required for quality control.
- CD-605-1, Concrete and Granite Curb
This detail has been revised to compliment the details in number 1, under New Construction Detail Sheets, below.
- CD-607-1, Public Sidewalk and Curb Ramps
The detail has been revised to be more comprehensive by adding curb ramp types and associated dimensions as well as, modifying and adding general notes.
- CD-610-1, Concrete Headwalls and Aprons
The depth of the headwalls and aprons below the ground line has been changed to 36 inches to be consistent with NJDEP standards. The volumes of the concrete have revised to reflect the change. A view entitled "End View of Outlet End" has been added to CD-610-1.2.
- CD-612-12, Thrie Beam and W Beam Terminal Connector.
This detail has been revised to compliment the details in number 1, under New Construction Detail Sheets, below.
- CD-813-1, Planting
This detail has been modified due to changes in standard horticultural practices, to address safety and maintenance issues as well as include details that were frequently used in the past but never standardized.
- BCD-8A, Bridge Chain Link Fence (Curved Top)
BCD-8B, Bridge Chain Link Fence (6' - 3" High)
In the previous booklet, these details were numbered BCD-8 and BCD-9, respectively.

New Construction Detail Sheets:

- CD-612-13, Beam Guide Rail Attachments
CD-612-14, Beam Guide Rail Attachments
CD-612-15, Beam Guide Rail Attachments
CD-612-16, Beam Guide Rail Attachments
These details are required to provide for NCHRP 350 compliance relative to bridge guide rail attachments.
- TCD-10, 4 Lanes, Undivided, 2 Lanes & Shoulder One Direction Closing
This Traffic Control Detail has been added.
- BCD-9 Stay In Place Forms

New Jersey Is An Equal Opportunity Employer • Printed on Recycled and Recyclable Paper

This detail sheet has been added to standardize detailing of SIP forms. This information was previously included in the Bridges and Structures Design Manual as guide plates.

Instructions to Designers

The English version of the Standard Roadway Construction - Traffic Control - Bridge Construction Details Booklet, dated 2001, shall be used on all future projects in English units. These details shall be used in conjunction with Department standard documents, such as the design manual, standard specifications, electrical details and EB specifications that have been or are in the process of being converted to English units. The actual implementation plan for the English projects will be announced when all the standards have been issued.

Distribution and Announcement Access Information

This announcement is being distributed electronically to our in-house staff and various public agencies based on our *Standard Details* booklet distribution list maintained by the Engineering Documents Unit.

Internet access to this BDC Announcement can be downloaded and viewed from the following New Jersey Department of Transportation Web Page:

<http://www.state.nj.us/transportation/cpm/BaselineDocuments/bdcdownload.htm>

In-house staff can copy or view this BDC Announcement files in the QM shared area on the NJDOT-FA-NTS7 server. To access this area, open Windows Explorer on an NJDOT Network Computer. Go to the drop down menu labeled **Tools**, and then select **Map Network Drive**. In the path box type in **\\NJDOT-FA-NTS7\QM**, then click on the OK button. All files are located in the **QM\BDC Announcements\BDC 00 Folder**.

Hard copies of this document can be acquired on a limited basis by contacting:

NJDOT
Engineering Documents Unit
E&O Building, 1st Floor
1035 Parkway Avenue, PO Box 600
Trenton, New Jersey 08625-0600
Phone: (609) 530-5587
Fax: (609) 530-6626

Recommended By:

Brian Strizki
Manager,
Quality Management Services

Approved By:

W. Dennis Keel
Assistant Commissioner,
Capital Program Management

Attachment: English version of the Standard Roadway Construction - Traffic Control - Bridge Construction Details Booklet, dated 2001 available upon request

BJS: JF
BDC00D-1.doc

New Jersey Is An Equal Opportunity Employer • Printed on Recycled and Recyclable Paper

TABLE OF CONTENTS - SHEET 1

SHEET #	DESCRIPTION	SHEET #	DESCRIPTION	SHEET #	DESCRIPTION
1	COVER SHEET	43	CD-612-1 BEAM GUIDE RAIL	87	CD-619-14 NON-BREAKAWAY SIGN SUPPORTS FOR GROUND MOUNTED SIGNS
2	TABLE OF CONTENTS - SHEET 1	44	CD-612-2 BEAM GUIDE RAIL, DUAL-FACED	88	CD-619-15 NON-BREAKAWAY SIGN SUPPORTS FOR GROUND MOUNTED SIGNS
3	TABLE OF CONTENTS - SHEET 2	45	CD-612-3 RUB RAIL	89	CD-620-1 DELINEATORS
		46	CD-612-4 BEAM GUIDE RAIL ANCHORAGES	90	CD-809-1 TOPSOIL STABILIZATION
	ROADWAY CONSTRUCTION DETAILS	47	CD-612-5 SLOTTED GUIDE RAIL TERMINALS AND EXTRUDER TERMINALS	91	CD-813-1 PLANTING
4	INDEX FOR STANDARD ROADWAY CONSTRUCTION DETAILS (Index Sheet 1)	48	CD-612-6 CONTROLLED RELEASE TERMINALS	92	CD-814-1 NONVEGETATIVE SURFACE DETAILS
5	INDEX FOR STANDARD ROADWAY CONSTRUCTION DETAILS (Index Sheet 2)	49	CD-612-7 MEDIAN GUIDE RAIL TREATMENT		
6	INDEX FOR STANDARD ROADWAY CONSTRUCTION DETAILS (Index Sheet 3)	50	CD-612-8 BEAM GUIDE RAIL END TREATMENT		
7	CD-107-1 NOISE CONTROL	51	CD-612-9 BEAM GUIDE RAIL ATTACHMENTS		TRAFFIC CONTROL DETAILS
8	CD-202-1 CONCRETE JOINT REMOVAL, MILLING AND RUMBLE STRIPS	52	CD-612-10 BEAM GUIDE RAIL ATTACHMENTS	93	INDEX SHEET FOR STANDARD TRAFFIC CONTROL DETAILS
9	CD-203-1 POROUS FILL AND EMBANKMENT	53	CD-612-11 BEAM GUIDE RAIL ATTACHMENTS	94	TCD-1 LEGEND & GENERAL NOTES
10	CD-212-1 TEMPORARY SOIL EROSION AND SEDIMENT CONTROL MEASURES	54	CD-612-12 THREE BEAM AND W BEAM TERMINAL CONNECTOR	95	TCD-2 SIGHT DIST., TAPER LENGTH, ESCAPE RAMP, CONST. BARRIER DETAIL ..
11	CD-212-2 TEMPORARY SOIL EROSION AND SEDIMENT CONTROL MEASURES	55	CD-612-13 BEAM GUIDE RAIL ATTACHMENTS	96	TCD-3 2 LANES, UNDIVIDED, LANE & SHOULDER CLOSING
12	CD-212-3 TEMPORARY SOIL EROSION AND SEDIMENT CONTROL MEASURES	56	CD-612-14 BEAM GUIDE RAIL ATTACHMENTS	97	TCD-4 2 LANES, UNDIVIDED, LANE & SHOULDER CLOSING W/FLAGGING
13	CD-306-1 CONTRACTION JOINTS IN CONCRETE BASE COURSE	57	CD-612-15 BEAM GUIDE RAIL ATTACHMENTS	98	TCD-5 2 LANES, UNDIVIDED, INTERSECTION
14	CD-405-1 CONCRETE SURFACE COURSE	58	CD-612-16 BEAM GUIDE RAIL ATTACHMENTS	99	TCD-6 2 LANES, UNDIVIDED, INTERSECTION
15	CD-405-2 CONCRETE SURFACE COURSE JOINT DETAILS	59	CD-614-1 CHAIN-LINK FENCE	100	TCD-7 2 LANES, UNDIVIDED, INTERSECTION
16	CD-405-3 CONCRETE SURFACE COURSE JOINT DETAILS	60	CD-614-2 CHAIN-LINK AND SNOW FENCE	101	TCD-8 4 LANES, UNDIVIDED, RIGHT LANE & SHOULDER CLOSING
17	CD-405-4 TIE BOLTS AND TIE BARS	61	CD-616-1 SLOPE AND CHANNEL PROTECTION	102	TCD-9 4 LANES, UNDIVIDED, LEFT LANE & SHOULDER CLOSING
18	CD-405-5 TRANSVERSE EXPANSION JOINT TYPE A	62	CD-617-1 TRAFFIC CONTROL DEVICES	103	TCD-10 4 LANES, UNDIVIDED, 2 LANES & SHLD. ONE DIRECTION CLOSING
19	CD-405-6 BRIDGE APPROACH SLABS AND TRANSITION SLABS ADJOINING ..	63	CD-617-2 TRAFFIC CONTROL DEVICES AND DETAILS	104	TCD-11 4 LANES, UNDIVIDED, INTERSECTION
20	CD-405-7 BRIDGE APPROACH SLABS AND TRANSITION SLABS ADJOINING ..	64	CD-617-3 PRECAST CONCRETE CURB, CONSTRUCTION BARRIER, TYPE 1	105	TCD-12 4 LANES, UNDIVIDED, INTERSECTION
21	CD-601-1 UNDERDRAINS	65	CD-617-4 PRECAST CONCRETE CURB, CONSTRUCTION BARRIER TYPE 4, (ALT. A)	106	TCD-13 4 LANES, UNDIVIDED, INTERSECTION
22	CD-602-1 PIPE END SECTIONS	66	CD-617-5 PRECAST CONCRETE CURB, CONSTRUCTION BARRIER TYPE 4, (ALT. B)	107	TCD-14 4 & 6 LANES, DIVIDED, RIGHT LANE & SHOULDER CLOSING
23	CD-602-2 CROSS DRAIN TRENCH CONSTRUCTION	67	CD-617-6 CONSTRUCTION SIGNS	108	TCD-15 4 & 6 LANES, DIVIDED, LEFT LANE CLOSING
24	CD-603-1 INLET GENERAL DETAILS	68	CD-617-7 CONSTRUCTION SIGNS	109	TCD-16 6 LANES, DIVIDED, (LEFT & RIGHT) TWO LANE CLOSING
25	CD-603-2 INLETS, TYPE A, B & C	69	CD-617-8 CONSTRUCTION IDENTIFICATION SIGN	110	TCD-17 6 LANES, DIVIDED, CENTER LANE CLOSURE
26	CD-603-3 INLETS, TYPE B1, B2, & B, B1 & B2 MODIFIED	70	CD-617-9 CONSTRUCTION IDENTIFICATION SIGNS	111	TCD-18 DIVIDED, EXIT RAMP CONSTRUCTION (LEFT & RIGHT)
27	CD-603-4 INLETS, TYPE E, E1, E2, & E5	71	CD-618-1 PLOWABLE PAVEMENT REFLECTOR LOCATION DETAILS	112	TCD-19 DIVIDED, EXIT RAMP CONSTRUCTION (LEFT & RIGHT) W/DECEL LANE
28	CD-603-5 INLETS, TYPE D1 & D2	72	CD-618-2 PLOWABLE PAVEMENT REFLECTOR LOCATION DETAILS	113	TCD-20 DIVIDED, ENTRANCE RAMP CONSTRUCTION (LEFT & RIGHT)
29	CD-603-6 CAST IRON EXTENSION FRAMES FOR EXISTING INLETS	73	CD-618-3 PLOWABLE PAVEMENT REFLECTOR LOCATION DETAILS	114	TCD-21 DIVIDED, ENTRANCE RAMP CONSTRUCTION (LEFT & RIGHT) W/ACCEL
30	CD-603-7 CAST IRON EXTENSION RINGS FOR EXISTING MANHOLES	74	CD-619-1 SIGNS	115	TCD-22 MULTI-LANE ROAD MOVING OPERATION
31	CD-603-8 MANHOLES	75	CD-619-2 SIGNS		
32	CD-603-9 PRECAST MANHOLES	76	CD-619-3 SIGNS		
33	CD-604-1 CONCRETE SLOPE GUTTERS	77	CD-619-4 STEEL U-POST SIGN SUPPORTS		
34	CD-605-1 CONCRETE AND GRANITE CURB	78	CD-619-5 STEEL U-POST SIGN SUPPORTS		
35	CD-605-2 BARRIER CURB AND VERTICAL CURB DETAILS	79	CD-619-6 STEEL U-POST SIGN SUPPORTS		
36	CD-605-3 BARRIER CURB	80	CD-619-7 BREAKAWAY SIGN SUPPORTS FOR GROUND MOUNTED SIGNS		
37	CD-607-1 PUBLIC SIDEWALK AND CURB RAMPS	81	CD-619-8 BREAKAWAY SIGN SUPPORTS FOR GROUND MOUNTED SIGNS		
38	CD-607-2 DRIVEWAYS	82	CD-619-9 BREAKAWAY SIGN SUPPORTS FOR GROUND MOUNTED SIGNS		
39	CD-608-1 CONCRETE AND HMA ISLANDS	83	CD-619-10 BREAKAWAY SIGN SUPPORTS FOR GROUND MOUNTED SIGNS		
40	CD-610-1 CONCRETE HEADWALLS AND APRONS	84	CD-619-11 BREAKAWAY SIGN SUPPORTS FOR GROUND MOUNTED SIGNS		
41	CD-610-2 CONCRETE CULVERTS	85	CD-619-12 BREAKAWAY SIGN SUPPORTS FOR GROUND MOUNTED SIGNS		
42	CD-611-1 MONUMENTS AND MONUMENT BOXES	86	CD-619-13 NON-BREAKAWAY SIGN SUPPORTS FOR GROUND MOUNTED SIGNS		

ABBREVIATIONS

CD = ROADWAY CONSTRUCTION DETAILS
 TCD = TRAFFIC CONTROL DETAILS
 BCD = BRIDGE CONSTRUCTION DETAILS

TABLE OF CONTENTS - SHEET 2

SHEET #	DESCRIPTION	SHEET #	DESCRIPTION	SHEET #	DESCRIPTION
BRIDGE CONSTRUCTION DETAILS					
116	INDEX SHEET FOR STANDARD BRIDGE CONSTRUCTION DETAILS				
117	BCD-1A BRIDGE DECK REHABILITATION WITH CONCRETE OVERLAY				
118	BCD-1B BRIDGE DECK REHABILITATION WITHOUT CONCRETE OVERLAY				
119	BCD-1C BRIDGE DECK REHABILITATION, DECK JOINT REPAIR (SHEET 1 OF 2)				
120	BCD-1D BRIDGE DECK REHABILITATION, DECK JOINT REPAIR (SHEET 2 OF 2)				
121	BCD-2 STRIP SEAL DECK JOINTS				
122	BCD-3 2'-8", 2'-10", AND 6'-6" PARAPETS				
123	BCD-4 BRIDGE MEDIAN BARRIER				
124	BCD-5 SAWCUT GROOVING FOR BRIDGE DECKS				
125	BCD-6 CONCRETE CLASSES AND PAY ITEMS				
126	BCD-7 MISCELLANEOUS BRIDGE ITEMS				
127	BCD-8A BRIDGE CHAIN LINK FENCE (CURVED TOP)				
128	BCD-8B BRIDGE CHAIN LINK FENCE (6'-3" HIGH)				
129	BCD-9 STAY-IN-PLACE FORMS				

ABBREVIATIONS
 CD = ROADWAY CONSTRUCTION DETAILS
 TCD = TRAFFIC CONTROL DETAILS
 BCD = BRIDGE CONSTRUCTION DETAILS

ID = . file = . scale = . queue = . pen table = .headseaduz_ghorabababaf-reahabi

BCD-9 - ORIGINAL SHEET

INDEX FOR STANDARD ROADWAY CONSTRUCTION DETAILS

INDEX SHEET 1

DESCRIPTION	CD	DESCRIPTION	CD	DESCRIPTION	CD
BEAM GUIDE RAIL		BEAM GUIDE RAIL (CONTINUED)		CURBS (CONTINUED)	
BEAM GUIDE RAIL	CD-612-1.1	BEAM GUIDE RAIL ATTACHMENTS (CONTINUED)		CURB TRANSITION	CD-605-2.3
GUIDE RAIL POST INSTALLATION IN ROCK	CD-612-1.2	GUIDE RAIL ATTACHMENT TO FOOTING	CD-612-11.1	METHOD OF DEPRESSING CURB AT DRIVEWAYS	CD-605-2.4
BEAM GUIDE RAIL, DUAL-FACED	CD-612-2.1	THREE BEAM	CD-612-12.1	24" x ____" CONCRETE / WHITE CONCRETE BARRIER CURB, DOWELLED	CD-605-3.1
RUB RAIL	CD-612-3	W BEAM TERMINAL CONNECTOR	CD-612-12.2	GENERAL NOTES	CD-605-3.2
C6 x 8.2	CD-612-3.1	GUIDE RAIL ATTACHMENT - NEW CONSTRUCTION NEW JERSEY BARRIER SHAPE PARAPET (NO ROADWAY CURBING ON APPROACH)	CD-612-13.1	OPENINGS TO BE CONSTRUCTED IN BARRIER CURB	CD-605-3.3
RUB RAIL SECTION	CD-612-3.2	GUIDE RAIL ATTACHMENT - NEW CONSTRUCTION NEW JERSEY BARRIER SHAPE PARAPET (WITH ROADWAY CURBING ON APPROACH)	CD-612-14.1	24" x 41" CONCRETE / WHITE CONCRETE BARRIER CURB	CD-605-3.4
BENT PLATE	CD-612-3.3	GUIDE RAIL ATTACHMENT - NEW CONSTRUCTION (SIDEWALK WITH PARAPET)	CD-612-15.1	BARRIER CURB AT LIGHTING POLE BASE INSTALLATION	CD-605-3.5
CARRIAGE BOLT DETAIL	CD-612-3.4	GUIDE RAIL ATTACHMENT - NEW CONSTRUCTION (SIDEWALK WITH STEEL RAILING)	CD-612-16.1	DELINEATORS	CD-620-1.1
RUB RAIL ANGLE ATTACHMENT	CD-612-3.5			DRIVEWAYS	
BEAM GUIDE RAIL IN LINE ANCHORAGE	CD-612-4.1	BRIDGE APPROACH SLABS		TYPE A	CD-607-2.1
BEAM GUIDE RAIL END ANCHORAGE	CD-612-4.2	BRIDGE APPROACH SLABS AND TRANSITION SLABS ADJOINING HMA CONCRETE PAVEMENT	CD-405-6.1	TYPE B	CD-607-2.2
ANCHOR PLATE	CD-612-4.3	BRIDGE APPROACH SLABS AND TRANSITION SLABS ADJOINING CONCRETE PAVEMENT	CD-405-7.1	GENERAL NOTES	CD-607-2.3
SLOTTED GUIDE RAIL TERMINALS	CD-612-5.1			TYPE C	CD-607-2.4
EXTRUDER TERMINALS	CD-612-5.2			TYPE D	CD-607-2.5
GRADING TREATMENT AT EXTRUDER TERMINALS	CD-612-5.3			TYPE E	CD-607-2.6
CONTROLLED RELEASE TERMINALS	CD-612-6.1			TYPE F	CD-607-2.7
CONTROLLED RELEASE TERMINALS ANCHORAGE	CD-612-6.2			TYPICAL DRIVEWAY TREATMENT	CD-607-2.8
GENERAL NOTES	CD-612-6.3	CONCRETE SURFACE COURSE		EMBANKMENT	
BEAM GUIDE RAIL TREATMENT		CONCRETE SURFACE COURSE, REINFORCEMENT, ____" THICK	CD-405-1.1	BENCHING DETAIL	CD-203-1.1
MEDIAN GUIDE RAIL WHEN CLEARANCE FROM BACK OF RAIL TO OBSTRUCTION IS 4' OR GREATER	CD-612-7.1	CULVERTS		LIMITS AND METHODS OF PLACING EMBANKMENT AND POROUS BACKFILL AND LIMITS OF ROADWAY EXCAVATION ADJACENT TO BRIDGE ABUTMENTS	CD-203-1.2
MEDIAN GUIDE RAIL WHEN CLEARANCE FROM BACK OF RAIL TO OBSTRUCTION IS MORE THAN 2' BUT LESS THAN 4'	CD-612-7.2	CONCRETE CULVERTS	CD-610-2.1		
TELESCOPING GUIDE RAIL END TERMINALS	CD-612-7.3	CONSTRUCTION JOINT OF CULVERT	CD-610-2.2	FENCES	
MEDIAN GUIDE RAIL TREATMENT AT ADJACENT BRIDGES	CD-612-7.4			CHAIN-LINK FENCE, ' HIGH	CD-614-1.1
WHERE CLEARANCE FROM BACK OF RAIL TO OBSTRUCTION IS LESS THAN 2'	CD-612-8.1	CURBS		DRIVE ANCHOR SHOE ASSEMBLY	CD-614-1.2
WHERE CLEARANCE FROM BACK OF RAIL TO OBSTRUCTION IS MORE THAN 2' BUT LESS THAN 4'	CD-612-8.2	GENERAL NOTES APPLYING TO ALL TYPES OF DOWELLED CURBS	CD-605-1.1	CHAIN-LINK FENCE ASSEMBLIES	CD-614-1.3
WHERE CLEARANCE FROM BACK OF RAIL TO OBSTRUCTION IS 4' OR GREATER	CD-612-8.3	9" x ____" CONCRETE / WHITE CONCRETE VERTICAL CURB, DOWELLED	CD-605-1.2	NOTES - CHAIN-LINK FENCE	CD-614-1.4
GUIDE RAIL FOR CUTS (END BURIED IN SLOPE)	CD-612-8.4	12" x 3" CONCRETE / WHITE CONCRETE SLOPING CURB, DOWELLED	CD-605-1.3	GATES, CHAIN-LINK FENCE, ____' WIDE	CD-614-1.5
ADDITIONAL LENGTH BEAM GUIDE RAIL POSTS	CD-612-8.5	CONCRETE / WHITE CONCRETE VERTICAL CURB MONOLITHIC WITH CONCRETE BASE COURSE	CD-605-1.4	SNOW FENCE	CD-614-2.1
SLOPE TREATMENT AT SLOTTED GUIDE RAIL TERMINALS	CD-612-8.6	12" x 13" CONCRETE / WHITE CONCRETE SLOPING CURB	CD-605-1.5	CHAIN-LINK FARM-TYPE FENCE	CD-614-2.2
WHERE RAIL ELEMENT WITH SPACER IS ATTACHED TO OBSTRUCTION	CD-612-8.7	CONCRETE / WHITE CONCRETE VERTICAL CURB	CD-605-1.6	SNOW FENCE, PLASTIC	CD-614-2.3
GENERAL NOTES	CD-612-8.8	CONCRETE / WHITE CONCRETE VERTICAL CURB MONOLITHIC WITH CONCRETE PAVEMENT	CD-605-1.7	HEADWALLS	
BEAM GUIDE RAIL ATTACHMENTS		NEW OR RESET GRANITE CURB	CD-605-1.8	CONCRETE HEADWALLS	CD-610-1.1
GUIDE RAIL ATTACHMENT TO BARRIER	CD-612-9.1	LIP CURB	CD-605-1.9	CONCRETE HEADWALLS AND APRONS	CD-610-1.2
MODIFICATION OF GUIDE RAIL ATTACHMENT TO PARAPET	CD-612-9.2	15" x VARIABLE HEIGHT CONCRETE / WHITE CONCRETE BARRIER CURB, DOWELLED	CD-605-2.1		
BRIDGE ATTACHMENT TYPES	CD-612-9.3	15" x 41" CONCRETE / WHITE CONCRETE BARRIER CURB	CD-605-2.2		
GENERAL NOTES	CD-612-9.4	CURB TREATMENT AT BERM SECTION AND ALL CURB ENDS			
GUIDE RAIL ATTACHMENT TO BALUSTRADE	CD-612-10.1				
GUIDE RAIL ATTACHMENT TO SIDEWALK	CD-612-10.2				

ED0002-1 ORIGINAL SHEET

INDEX FOR STANDARD ROADWAY CONSTRUCTION DETAILS

INDEX SHEET 2

DESCRIPTION	CD	DESCRIPTION	CD	DESCRIPTION	CD
INLETS AND MANHOLES		ISLANDS		MONUMENTS	
CONNECTION OF PIPE AND INLET FOR PRECAST INLET	CD-603-1.1	CONCRETE/WHITE CONCRETE ISLAND ON EXISTING PAVEMENT	CD-608-1.1	MONUMENTS	CD-611-1.1
RISER JOINT DETAIL FOR PRECAST INLETS	CD-603-1.2	LONGITUDINAL & TRANSVERSE JOINT TREATMENT FOR CONCRETE ISLAND	CD-608-1.2	MONUMENT BOXES FOR NEW MONUMENTS	CD-611-1.2
LADDER RUNG DETAIL	CD-603-1.3	HMA ISLAND, 10" THICK	CD-608-1.3		
DETAIL OF INVERT FOR INLET WITHOUT CONTINUOUS PIPE	CD-603-1.4	CONCRETE / WHITE CONCRETE ISLAND, 4" THICK	CD-608-1.4	NOISE CONTROL	
COPOLYMER POLYPROPYLENE PLASTIC LADDER RUNG	CD-603-1.5			TEMPORARY NOISE BARRIER	CD-107-1.1
GENERAL NOTES	CD-603-1.6	JOINTS			
NEW MANHOLE CASTINGS, SQUARE FRAME, CIRCULAR COVER	CD-603-1.7	CONCRETE JOINT REMOVAL, MILLING AND RUMBLE STRIPS	CD-202-1	PIPES	
BICYCLE SAFE GRATE (CAST IRON)	CD-603-1.8	JOINT REMOVAL	CD-202-1.1	PIPE END SECTIONS	CD-602-1
FRAME-BACK-CURB PIECE FOR INLET TYPE B AND TYPE C	CD-603-2.1	MILLING TRANSITIONS	CD-202-1.2	END SECTIONS FOR METAL PIPE	CD-602-1.1
INLETS, TYPE C WITH C.I. CURB PIECE-BACK-FRAME AND GRATE	CD-603-2.2	END TREATMENT FOR MILLING OPERATIONS	CD-202-1.3	END SECTIONS FOR CONCRETE PIPE	CD-602-1.2
METHOD OF SETTING CASTING FOR B TYPE INLETS WHERE CURB PIECE HEIGHT IS 2" GREATER THAN CURB FACE	CD-603-2.3	CONTRACTION JOINT ASSEMBLY	CD-306-1.1	CONCRETE COLLAR	CD-602-1.3
FRAME FOR INLETS, TYPE A	CD-603-2.4	TRANSVERSE CONTRACTION JOINT	CD-306-1.2	STORMWATER OUTFALL PROTECTION	CD-602-1.4
ALTERNATE BACK PLATE	CD-603-2.5	CONCRETE SURFACE COURSE JOINT DETAILS	CD-405-2	CROSS DRAIN TRENCH CONSTRUCTION	CD-602-2
INLETS, TYPE B WITH C.I. CURB PIECE-BACK-FRAME AND GRATE	CD-603-2.6	METAL CHANNEL CAP FOR JOINT FILLER	CD-405-2.1	CONCRETE SURFACE COURSE REPLACEMENT AT CROSS DRAIN TRENCH	CD-602-2.1
INLETS, TYPE B MODIFIED	CD-603-3.1	CONCRETE HEADER	CD-405-2.2	HMA REPLACEMENT WHERE CONCRETE COURSE IS REMOVED AT CROSS DRAIN TRENCH	CD-602-2.2
INLETS, TYPE B1 MODIFIED AND TYPE B2 MODIFIED	CD-603-3.2	LONGITUDINAL JOINT	CD-405-2.3	HMA REPLACEMENT WHERE EXISTING OVERLAY AND CONCRETE COURSE IS REMOVED AT CROSS DRAIN TRENCH WITH PROPOSED RESURFACING	CD-602-2.3
METHOD OF DEPRESSING INLET AT SHOULDERS	CD-603-3.3	PROCEDURE TO BE FOLLOWED IN THE EDGING AND FINISHING OF ALL TRANSVERSE JOINTS	CD-405-2.4	HMA REPLACEMENT WHERE EXISTING CONCRETE COURSE IS REMOVED AT CROSS DRAIN TRENCH WITH PROPOSED RESURFACING	CD-602-2.4
FRAME TO BE USED FOR INLETS, TYPE B MODIFIED	CD-603-3.4	METHOD OF CONSTRUCTION LONGITUDINAL JOINT WHERE NO KEYWAY EXISTS	CD-405-2.5	TRANSVERSE JOINT TIE IN CONCRETE SURFACE COURSE FOR CONDUIT OR CROSS DRAIN TRENCHES	CD-602-2.5
INLETS, TYPE B1 AND TYPE B2	CD-603-3.5	CONCRETE SURFACE COURSE JOINT DETAILS	CD-405-3	MINIMUM DEPTH OF ADDITIONAL EXCAVATION OR PIPE BEDDING	CD-602-2.6
INLETS, TYPE E1 AND TYPE E2	CD-603-4.1	DETAILS OF JOINT BETWEEN EXISTING CONCRETE TO REMAIN AND PROPOSED CONCRETE	CD-405-3.1		
INLETS, TYPE E	CD-603-4.2	LONGITUDINAL JOINT TIE FOR NARROW WIDTH WIDENING	CD-405-3.2	PLOWABLE PAVEMENT REFLECTORS	
FRAMES FOR INLETS, TYPE E	CD-603-4.3	DETAIL OF CONTRACTION JOINT FOR NON-REINFORCED CONCRETE SURFACE COURSE	CD-405-3.3	TEMPORARY PAVEMENT MARKERS	CD-617-2.6
INLETS, TYPE ES	CD-603-4.4	TIE BOLTS AND TIE BARS	CD-405-4	TYPICAL DECELERATION LANE TREATMENT	CD-618-1.1
INLET CASTINGS, TYPE E5	CD-603-4.5	TIE BOLT ASSEMBLY	CD-405-4.1	LEGEND	CD-618-1.2
INLETS TYPE D1	CD-603-5.1	LOCATION OF TIE BOLTS OR TIE BARS IN CONCRETE SURFACE COURSE	CD-405-4.2	TYPICAL ACCELERATION LANE TREATMENT	CD-618-1.3
INLETS TYPE D2	CD-603-5.2	TRANSVERSE EXPANSION JOINT TYPE A	CD-405-5	TYPICAL PAVED MEDIAN TREATMENT	CD-618-1.4
CAST IRON CURB PIECE FOR INLETS, TYPE D1 AND D2	CD-603-5.3	TYPICAL CROSS SECTION, PLAN, ELEVATION	CD-405-5.1	TYPICAL DIVISIONAL ISLAND TREATMENT	CD-618-2.1
CAST IRON EXTENSION FRAMES FOR EXISTING INLETS	CD-603-6.1	DOWEL SPECIFICATIONS	CD-405-5.2	NARROW BRIDGE OR CULVERT TREATMENT	CD-618-2.2
CAST IRON EXTENSION RINGS FOR EXISTING MANHOLES	CD-603-7.1	DETAILS OF JOINT FILLER	CD-405-5.3	LEGEND	CD-618-2.3
STANDARD MANHOLE FRAME AND COVER	CD-603-8.1	ALTERNATE JOINT DEVICES	CD-405-5.4	TYPICAL TWO LANE SECTION	CD-618-2.4
MANHOLES, MANHOLES 5 FOOT DIAMETER, MANHOLES 6 FOOT DIAMETER	CD-603-8.2	DETAILS OF SHEET METAL SLEEVES	CD-405-5.5	TYPICAL LEFT TURN LANE SECTION	CD-618-2.5
GENERAL NOTES	CD-603-8.3			TYPICAL MULTI-LANE DIVIDED SECTION	CD-618-3.1
MANHOLES PRECAST CONCRETE	CD-603-9.1	LANDSCAPING		TYPICAL MULTI-LANE UNDIVIDED SECTION	CD-618-3.2
MANHOLES 5' DIAMETER, MANHOLES 6' DIAMETER PRECAST CONCRETE	CD-603-9.1	TOPSOIL STABILIZATION	CD-809-1.1	METHOD FOR DETERMINING REFLECTOR SPACING ON HORIZONTAL CURVES	CD-618-3.3
48" PRECAST REINFORCED CONCRETE MANHOLE FLAT TOP	CD-603-9.2	PLANTING	CD-813-1.1	LEGEND	CD-618-3.4
PRECAST MANHOLE RISER JOINT	CD-603-9.3	NONVEGETATIVE SURFACE DETAILS	CD-814-1.1	RUMBLE STRIPS	CD-202-1.4

RECORDS - ORIGINAL SHEET

INDEX FOR STANDARD ROADWAY CONSTRUCTION DETAILS

INDEX SHEET 3

DESCRIPTION	CD	DESCRIPTION	CD	DESCRIPTION	CD
SIDEWALK		SOIL EROSION AND SEDIMENT CONTROL (CONTINUED)			
CONCRETE SIDEWALK, 4" THICK	CD-607-1.1	TEMPORARY STONE CHECK DAM	CD-212-2.2		
HMA SIDEWALK, 5 1/2" THICK	CD-607-1.2	TEMPORARY STONE OUTLET SEDIMENT TRAPS, ___' x ___'	CD-212-2.3		
CURB RAMPS	CD-607-1.3	INLET FILTERS	CD-212-2.4		
		INLET PROTECTION HAYBALE BARRIER	CD-212-2.5		
SIGNS		ROADWAY GRADING	CD-212-3.1		
CONSTRUCTION SIGNS	CD-617-6.1	TEMPORARY RUNOFF DIVERSION	CD-212-3.2		
	CD-617-7.1	STREAM DIVERSION	CD-212-3.3		
INTERSTATE CONSTRUCTION IDENTIFICATION SIGN	CD-617-8.1	FLOATING TURBIDITY BARRIER	CD-212-3.4		
CONSTRUCTION IDENTIFICATION SIGNS	CD-617-9.1				
SIGNS	CD-619-1.1	TRAFFIC CONTROL			
	CD-619-2.1	DRUMS	CD-617-1.1		
	CD-619-3.1	TRAFFIC CONES	CD-617-1.2		
		BREAKAWAY BARRICADES	CD-617-1.3		
SIGN SUPPORTS		ILLUMINATED FLASHING ARROWS, ___ x ___	CD-617-2.1		
STEEL U-POST SIGN SUPPORTS	CD-619-4.1	DELINEATOR GUIDE POSTS	CD-617-2.2		
	CD-619-5.1	VERTICAL PANELS	CD-617-2.3		
	CD-619-6.1	STOP/SLOW PADDLE	CD-617-2.4		
BREAKAWAY SIGN SUPPORTS FOR GROUND MOUNTED SIGNS	CD-619-7.1	TEMPORARY SIDEWALK	CD-617-2.5		
	CD-619-8.1	PRECAST CONCRETE CURB, CONSTRUCTION BARRIER, TYPE 1	CD-617-3.1		
	CD-619-9.1	ANCHORAGE FOR TYPE 4 BARRIER USED AS TYPE 1	CD-617-3.2		
	CD-619-10.1	PRECAST CONCRETE CURB, CONSTRUCTION BARRIER, TYPE 4 (ALTERNATE A)	CD-617-4.1		
	CD-619-11.1	PRECAST CONCRETE CURB, CONSTRUCTION BARRIER, TYPE 4 (ALTERNATE B)	CD-617-5.1		
	CD-619-12.1				
NON-BREAKAWAY SIGN SUPPORTS FOR GROUND MOUNTED SIGNS	CD-619-13.1	UNDERDRAINS			
	CD-619-14.1	UNDERDRAIN TYPE F WITH POROUS PIPE	CD-601-1.1		
	CD-619-15.1	UNDERDRAIN TYPE F WITH PERFORATED PIPE			
SLOPE AND CHANNEL PROTECTION		SUBBASE OUTLET DRAIN WITH 6" CORRUGATED UNDERDRAIN PIPE	CD-601-1.2		
RIPRAP STONE CHANNEL / SLOPE TREATMENT	CD-616-1.1	COMBINED STORM DRAIN AND OUTLET TRENCH IN ROCK CUTS	CD-601-1.3		
SLOPE TREATMENT AT LOW POINTS OF UMBRELLA SECTIONS	CD-616-1.2				
SLOPE GUTTERS					
CONCRETE SLOPE GUTTERS, 6" THICK	CD-604-1.1				
SOIL EROSION AND SEDIMENT CONTROL					
SILT FENCE	CD-212-1.1				
ATTACHING TWO SILT FENCES	CD-212-1.2				
HEAVY DUTY SILT FENCE	CD-212-1.3				
TEMPORARY SLOPE DRAIN	CD-212-1.4				
HAYBALE CHECK DAM WITH TEMPORARY STONE OUTLET	CD-212-1.5				
INLET SEDIMENT TRAPS	CD-212-2.1				

ID = ... file = ... date = ... queue = ... scale = ...



BROOKS - ORIGINAL SHEET

pen table = f:\roadway\pilot\p\half-scale.tbl
scale =
queue =
date =
file =
ID =

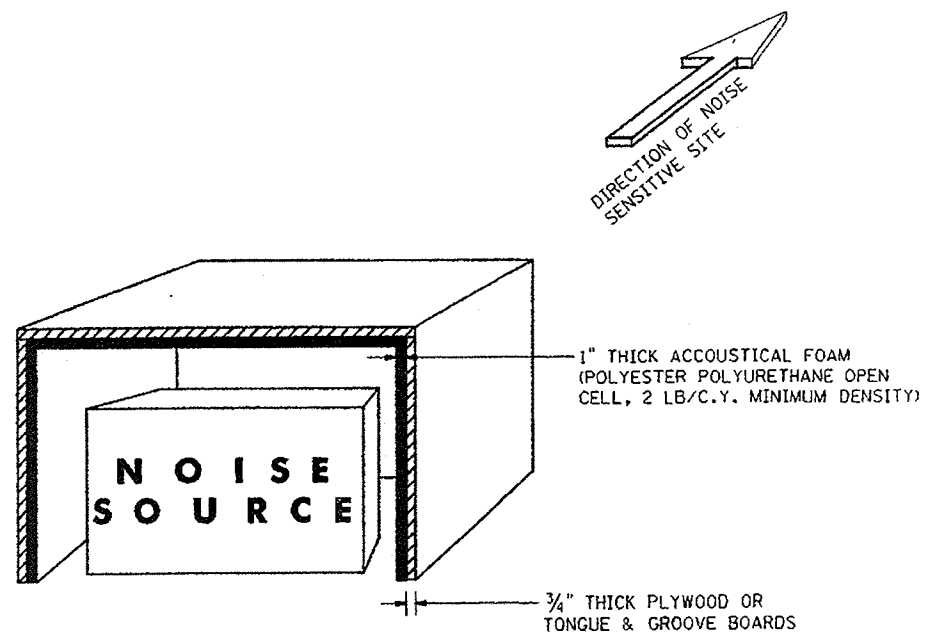

TEMPORARY NOISE BARRIER

CD-107-1.1

NOISE CONTROL

N.T.S.

CD-107-1

NEW JERSEY DEPARTMENT OF TRANSPORTATION

CONSTRUCTION DETAILS

RECORDS - ORIGINAL SHEET

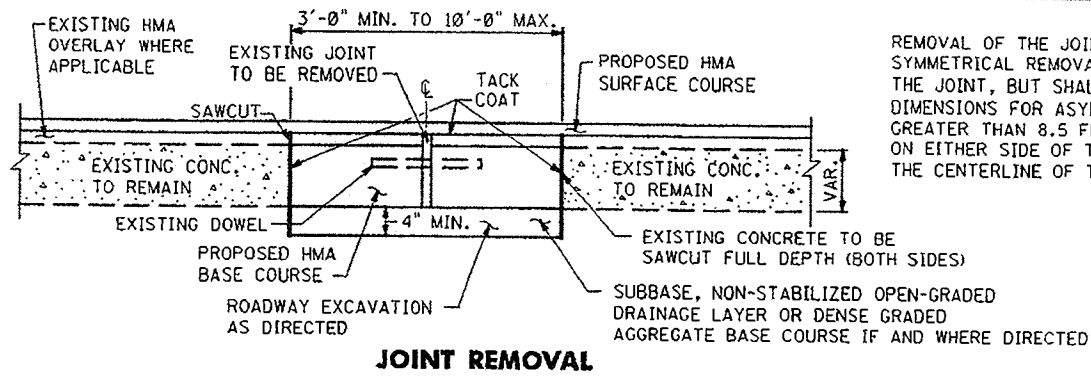

REMOVAL OF THE JOINT SHALL NOT BE LIMITED TO A SYMMETRICAL REMOVAL ABOUT THE CENTERLINE OF THE JOINT, BUT SHALL BE AS DIRECTED. THE LIMITING DIMENSIONS FOR ASYMMETRIC REMOVAL SHALL NOT BE GREATER THAN 8.5 FEET NOR LESS THAN 1.5 FEET ON EITHER SIDE OF THE JOINT WHEN MEASURED FROM THE CENTERLINE OF THE JOINT.

CD-202-1.1

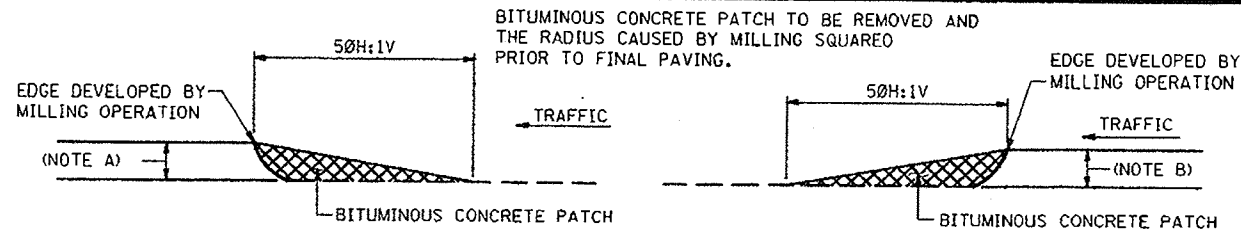

NOTE A:
BITUMINOUS CONCRETE PATCH MILLING TRANSITION TO BE USED WHEN LEADING EDGE DEVELOPED BY MILLING OPERATION IS EQUAL TO OR GREATER THAN 1 INCH. NONE REQUIRED FOR EDGE LESS THAN 1 INCH.

NOTE B:
BITUMINOUS CONCRETE PATCH MILLING TRANSITION TO BE USED WHEN TRAILING EDGE DEVELOPED BY MILLING OPERATION IS EQUAL TO OR GREATER THAN 1 1/2 INCHES. NONE REQUIRED FOR EDGE LESS THAN 1 1/2 INCHES.

MILLING TRANSITIONS

CD-202-1.2

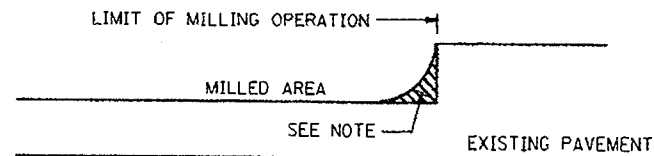

NOTE:
AT THE LIMITS OF THE MILLING OPERATION THE BITUMINOUS MATERIAL LEFT BY THE DRUM RADIUS SHALL BE REMOVED. SAWING OR TRANSVERSE MILLING SHALL BE USED TO INSURE THAT THE FACE IS CLEAN AND VERTICAL. THIS END TREATMENT IS NOT APPLICABLE TO TEMPORARY LIMITS OF MILLING (i.e. END OF WORKDAY). IT IS APPLICABLE TO ALL AREAS WHERE THE COMPLETED MILLING OPERATION MATCHES ANY EXISTING PAVEMENT INCLUDING BRIDGES.

END TREATMENT FOR MILLING OPERATIONS

CD-202-1.3

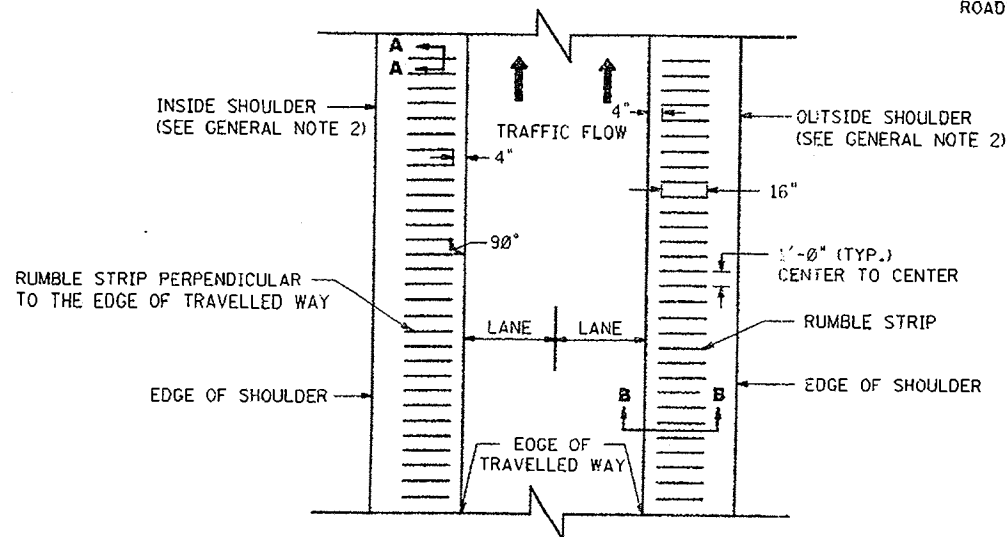
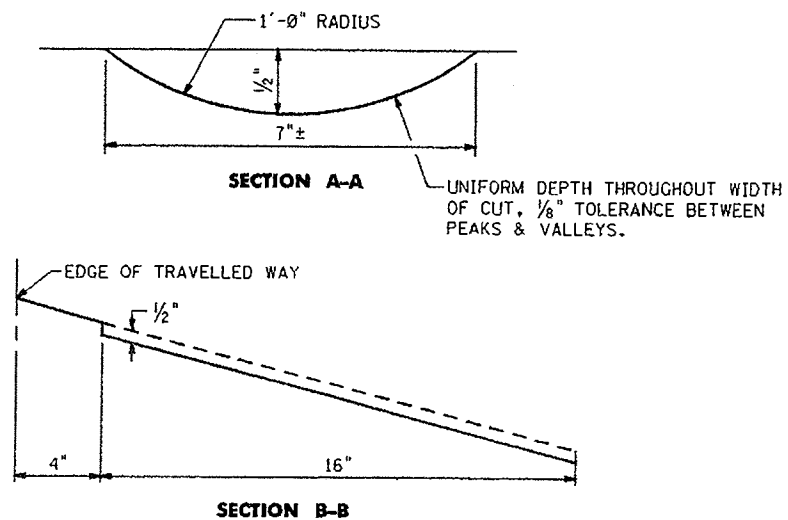

RUMBLE STRIPS

CONCRETE JOINT REMOVAL, MILLING AND RUMBLE STRIPS

N.T.S.

HMA = HOT ASPHALT MIX

CD-202-1

NEW JERSEY DEPARTMENT OF TRANSPORTATION

CONSTRUCTION DETAILS

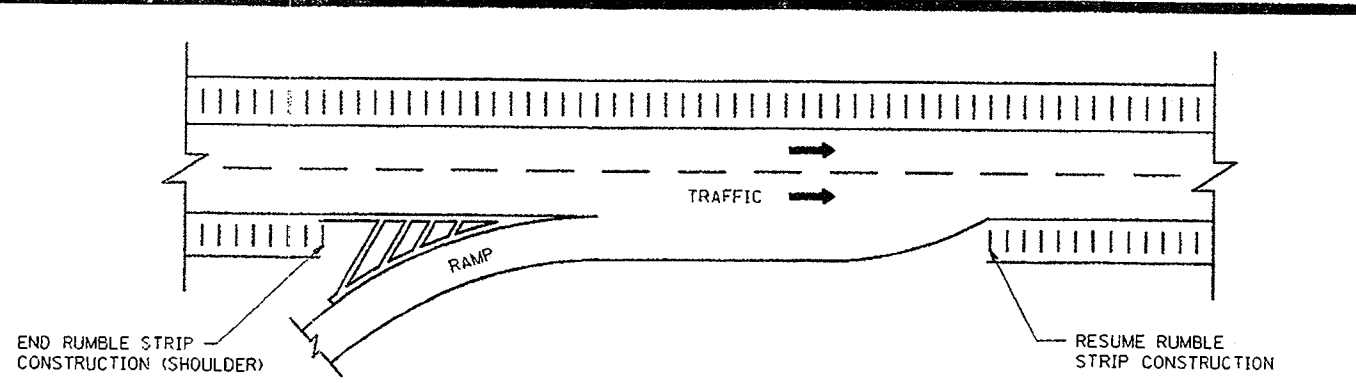

TYPICAL ACCELERATION LANE (RUMBLE STRIP CONSTRUCTION)

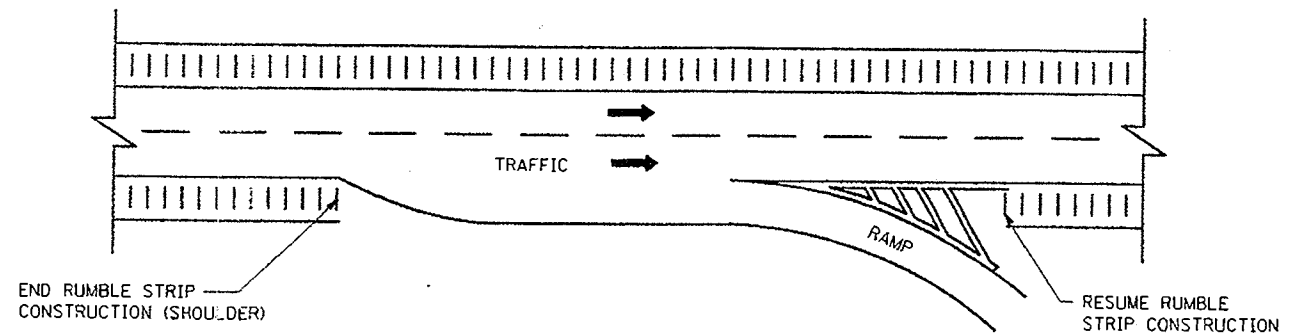

TYPICAL DECELERATION LANE (RUMBLE STRIP CONSTRUCTION)

GENERAL NOTES:

1. THE MINIMUM LENGTH OF RUMBLE STRIPS MEASURED LONGITUDINALLY ALONG THE SHOULDER SHALL BE 100 FEET.
2. RUMBLE STRIPS SHALL BE CONSTRUCTED ON 5 FEET OR WIDER INSIDE SHOULDERS AND 8 FEET OR WIDER OUTSIDE SHOULDERS.
3. RUMBLE STRIPS SHALL NOT BE CONSTRUCTED ACROSS BRIDGE DECKS.
4. RUMBLE STRIPS SHALL NOT BE CONSTRUCTED WITHIN 100 FEET BEFORE AND 100 FEET AFTER THE P.C. OF INTERSECTING ROADWAYS AND DRIVEWAYS.

CD-202-1.4

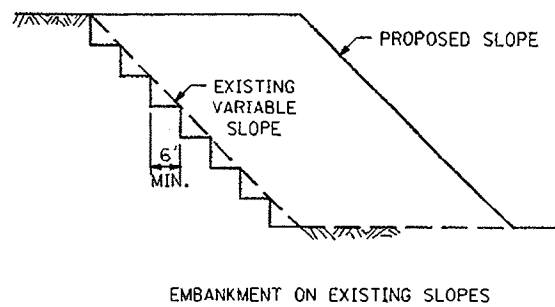

BENCHING DETAIL

CD-203-1.1

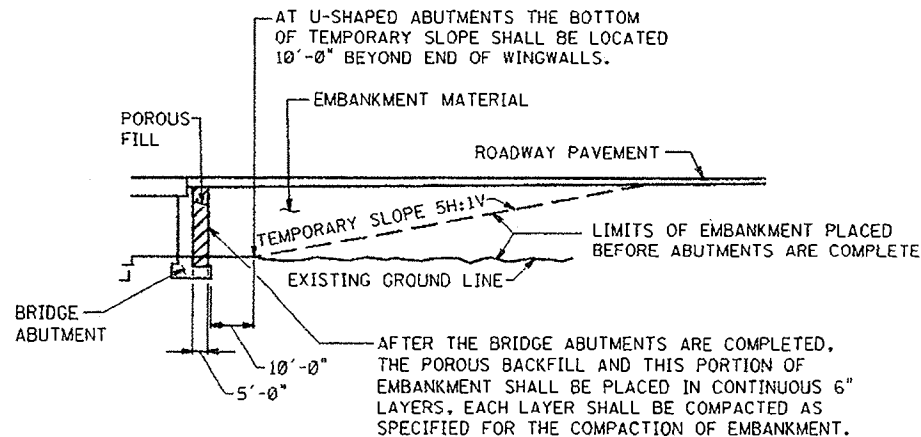

**METHOD A
OVERPASS ROADWAY COMPLETELY IN FILL**

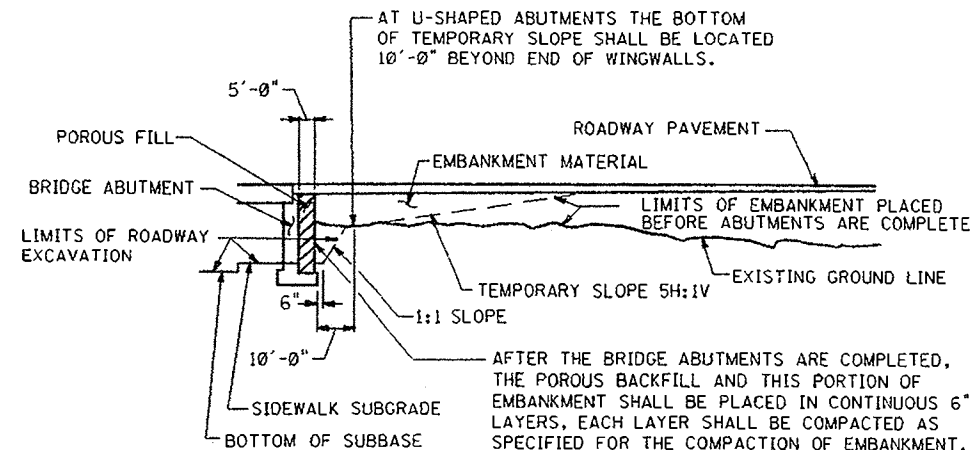

**METHOD B
OVERPASS ROADWAY PARTLY IN FILL**

NOTES:

AT U-SHAPED WINGWALLS THE METHODS OF PLACING AND COMPACTING EMBANKMENT AND POROUS BACKFILL AS SHOWN SHALL APPLY. FOR U-SHAPED WINGWALLS EXCAVATION BELOW THE BOTTOM LIMITS OF ROADWAY EXCAVATION SHOWN ON THESE SECTIONS SHALL BE PAID FOR AS BRIDGE FOUNDATION EXCAVATION. POROUS BACKFILL SHALL BE PLACED BETWEEN THE BACKFACES OF U-SHAPED WINGWALLS AND VERTICAL PLANES AS SHOWN FOR ABUTMENTS.

BRIDGE FOUNDATION EXCAVATION. POROUS BACKFILL SHALL BE PLACED BETWEEN THE BACKFACES OF U-SHAPED WINGWALLS AND VERTICAL PLANES AS SHOWN FOR ABUTMENTS.

AT HIGHWAY BRIDGES OVERPASSING RAILROADS AND STREAMS, THE LIMITS AND METHODS OF PLACING AND COMPACTING EMBANKMENTS AS SHOWN SHALL APPLY. WHERE POROUS BACKFILL IS CALLED FOR THE LIMITS AND METHODS OF PLACING AND COMPACTING IT AS SHOWN SHALL ALSO APPLY.

THE LIMITS SHOWN FOR ROADWAY EXCAVATION DO NOT APPLY TO RAILROAD AND STREAM BRIDGES UNLESS SPECIFICALLY PROVIDED ELSEWHERE IN THE CONTRACT. THESE SECTIONS AND REQUIREMENTS DO NOT APPLY TO ARCH BRIDGES.

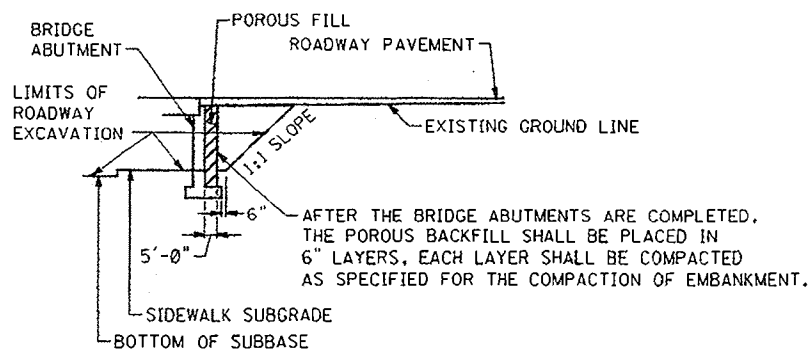

**METHOD C
OVERPASS ROADWAY AT EXISTING GRADE**

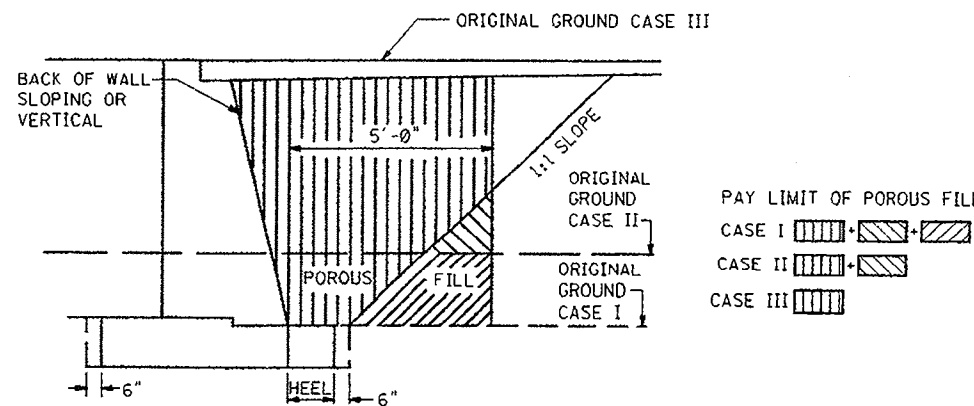

**METHOD D
WHEN HEEL IS LESS THAN 4' - 6"**

NOTE:
LIMITS OF ROADWAY EXCAVATION AND METHODS OF PLACING EMBANKMENT, OTHER THAN POROUS FILL, SHALL BE AS SHOWN IN METHODS A, B, OR C, WHICHEVER IS APPLICABLE.

**POROUS FILL
AND EMBANKMENT**

N.T.S.

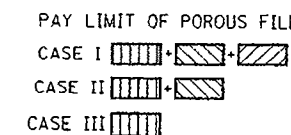

**LIMITS AND METHODS OF PLACING EMBANKMENT AND POROUS BACKFILL
AND LIMITS OF ROADWAY EXCAVATION ADJACENT TO BRIDGE ABUTMENTS**

CD-203-1.2

CD-203-1

NEW JERSEY DEPARTMENT OF TRANSPORTATION

CONSTRUCTION DETAILS

pen table # A:\roadway\plot\pnt\half-scale.tbl
 scale # .
 queue # .
 date # .
 file # .
 ID # .
 BD0001 - ORIGINAL SHEET

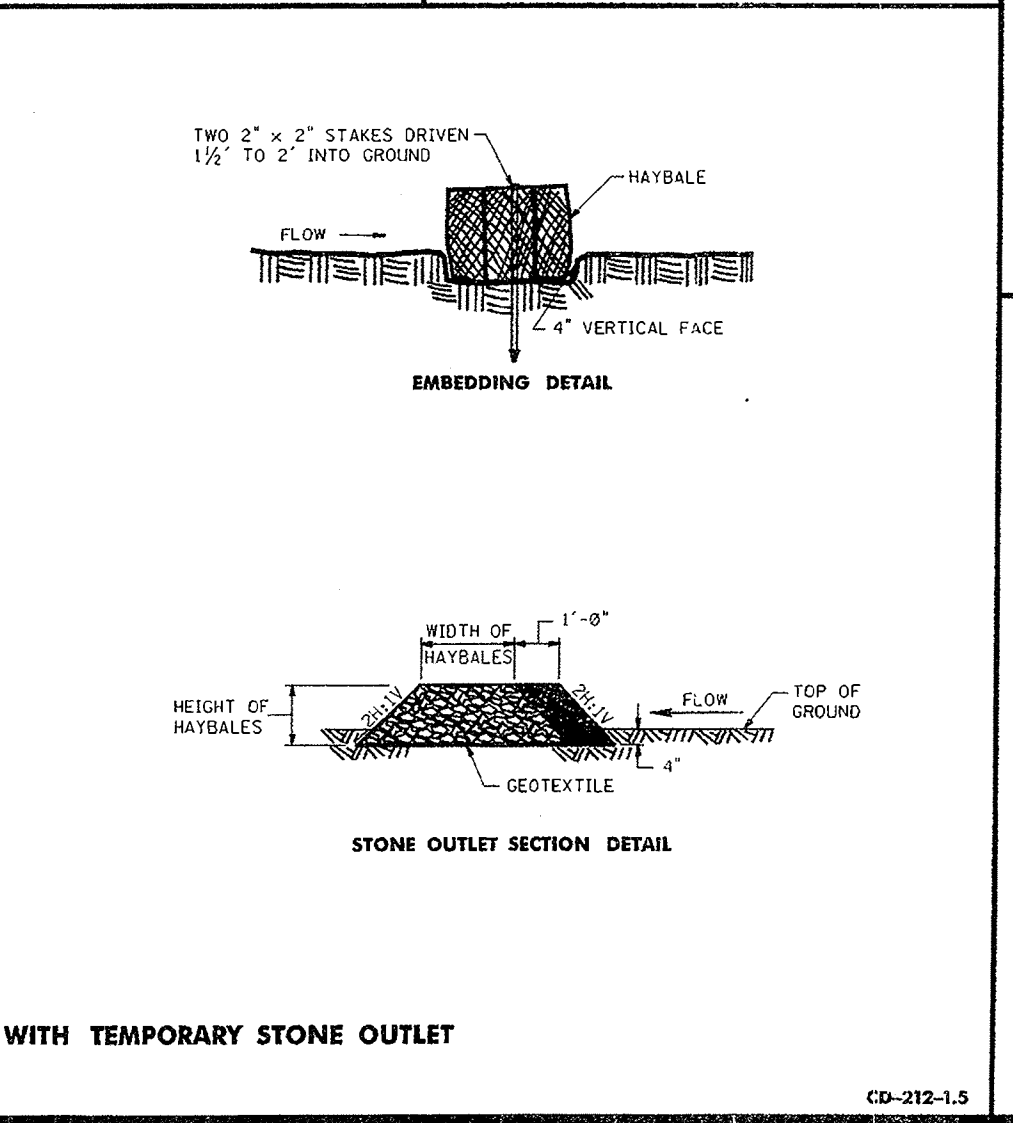
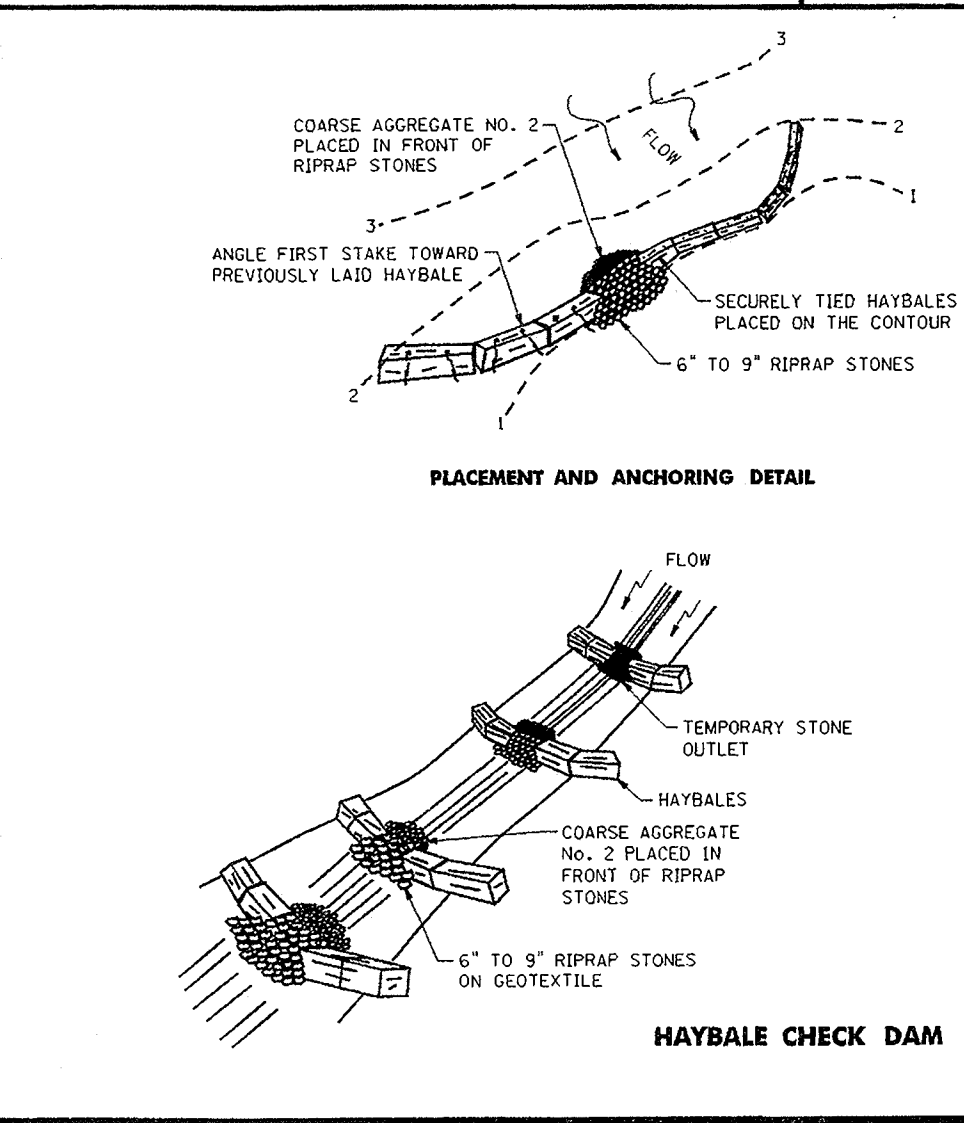
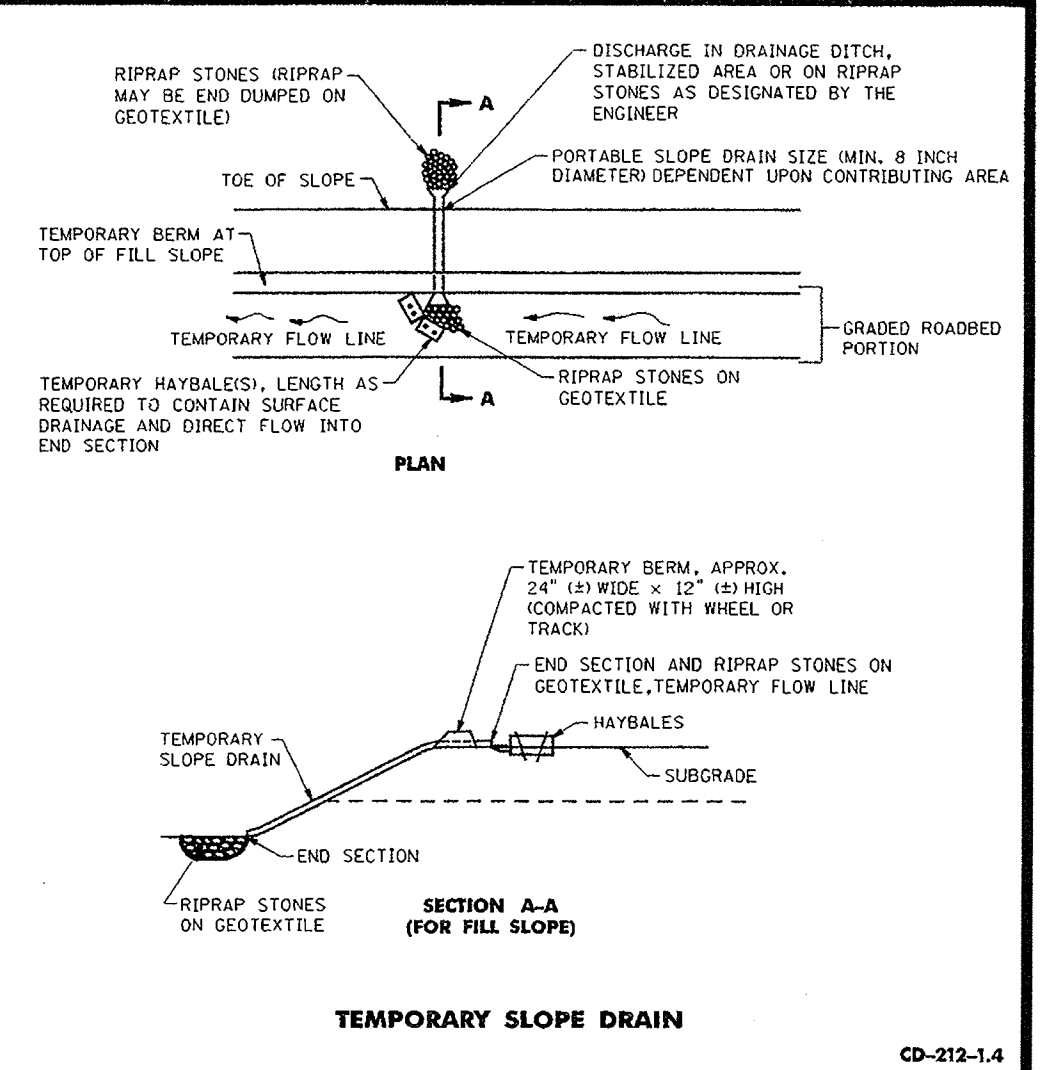
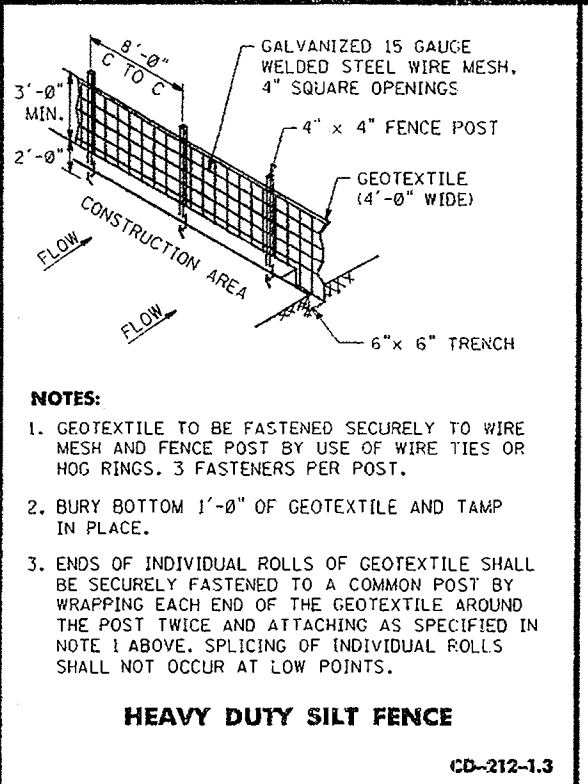
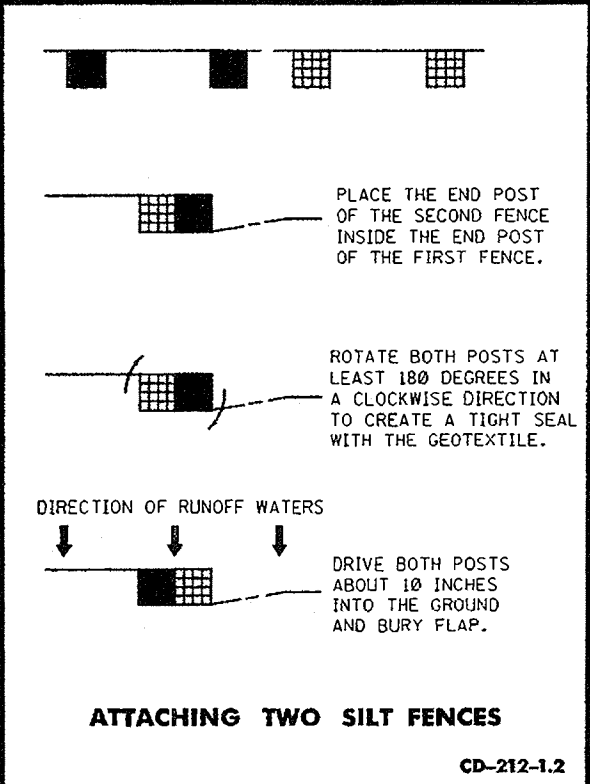
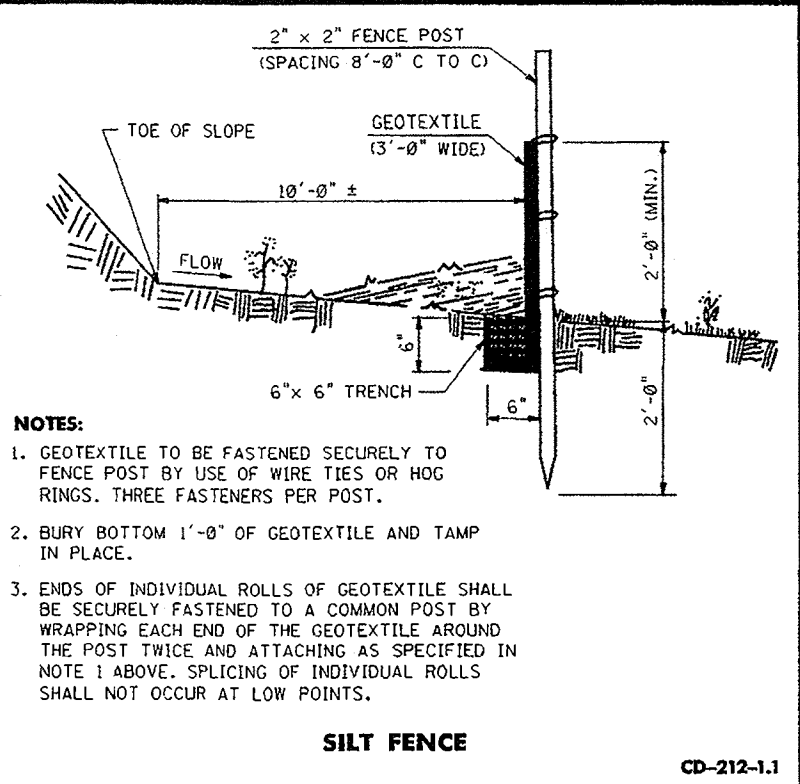

TEMPORARY SOIL EROSION AND SEDIMENT CONTROL MEASURES
N.T.S.

CD-212-1
 NEW JERSEY DEPARTMENT OF TRANSPORTATION
CONSTRUCTION DETAILS
 10
 129

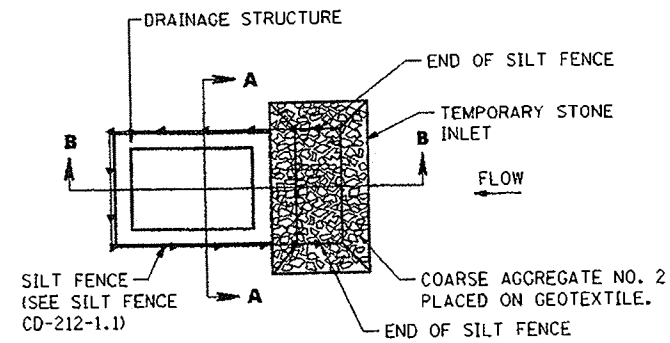

PLAN

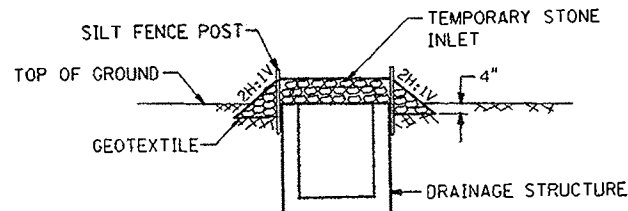

SECTION A-A

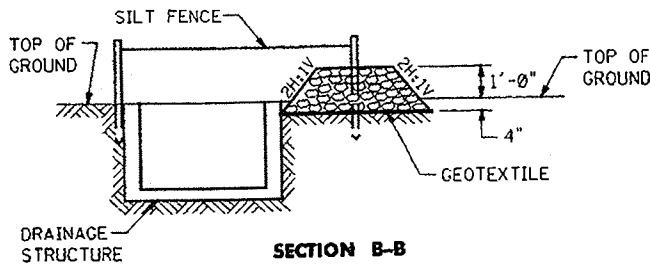

SECTION B-B

INLET SEDIMENT TRAPS

CD-212-2.1

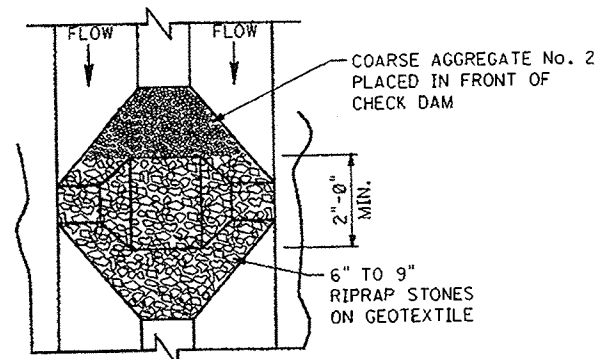

PLAN

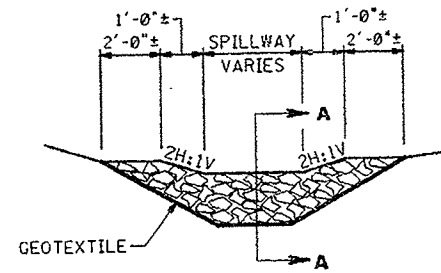

ELEVATION

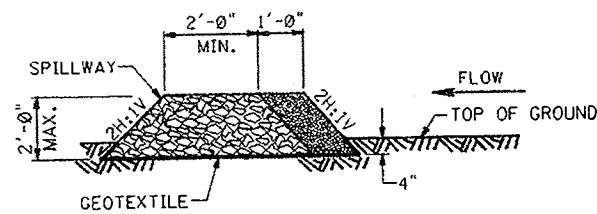

SECTION A-A

TEMPORARY STONE CHECK DAM

CD-212-2.2

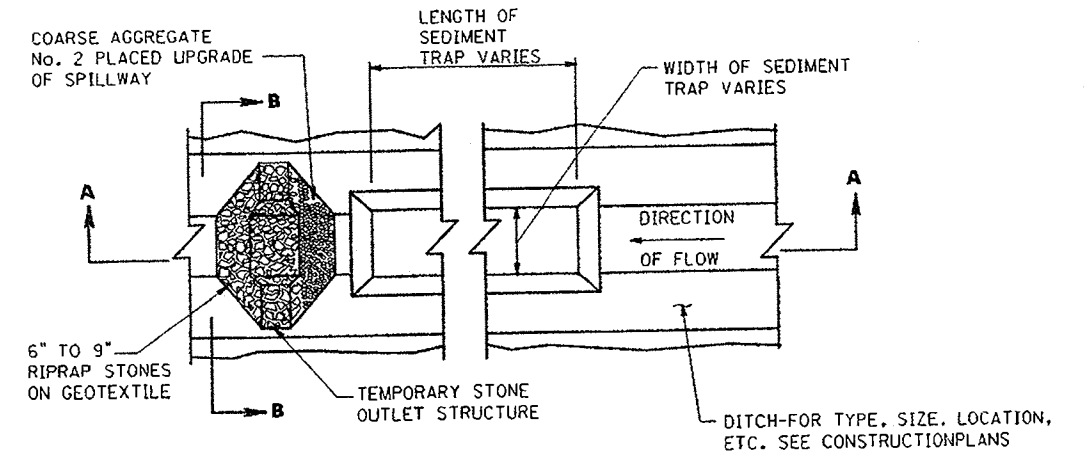

PLAN

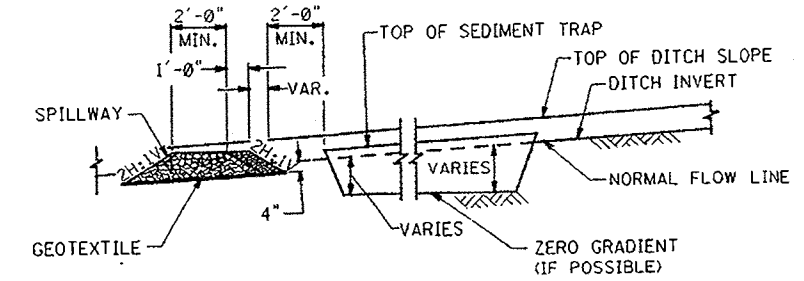

SECTION A-A

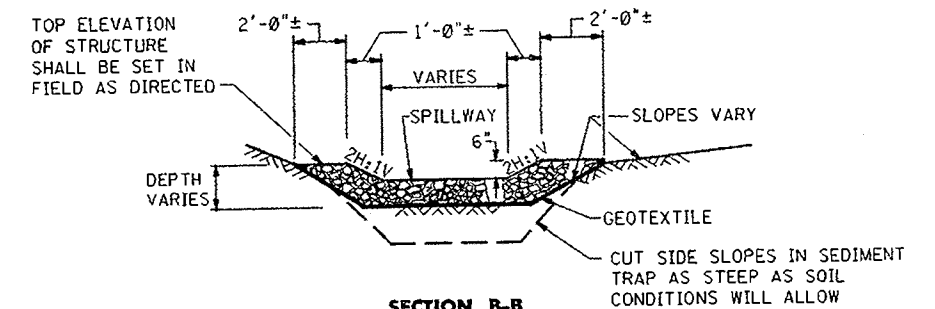

SECTION B-B

TEMPORARY STONE OUTLET SEDIMENT TRAPS, 'x'

CD-212-2.3

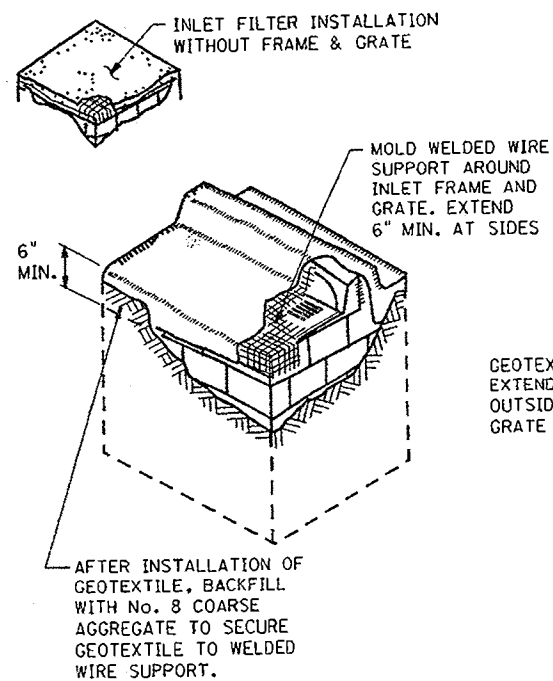

NEW CONSTRUCTION

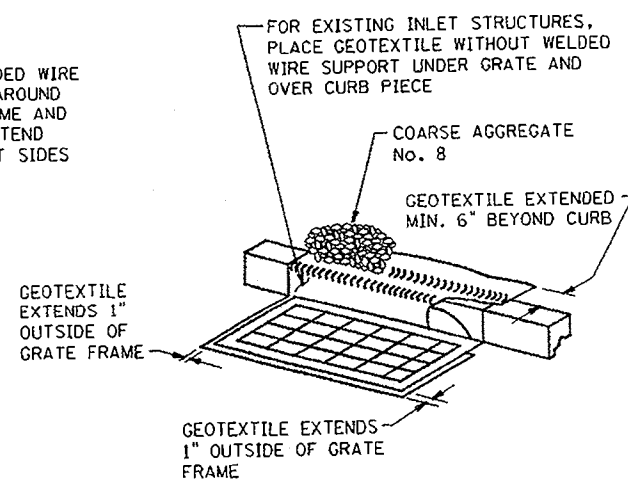

EXISTING INLET

INLET FILTERS

CD-212-2.4

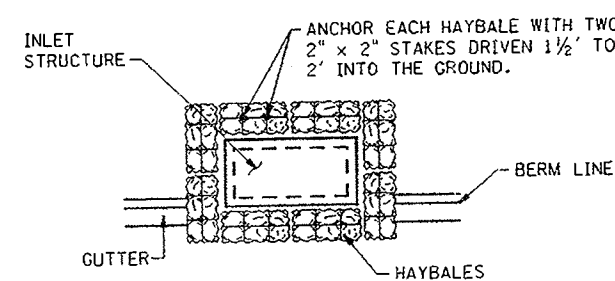

NOTE:
WHERE STAKING IS NOT PRACTICAL, HAYBALES SHALL BE TIED TOGETHER TO PREVENT MOVEMENT.

INLET PROTECTION HAYBALE BARRIER

CD-212-2.5

TEMPORARY SOIL EROSION AND SEDIMENT CONTROL MEASURES

N.T.S.

CD-212-2

NEW JERSEY DEPARTMENT OF TRANSPORTATION

CONSTRUCTION DETAILS

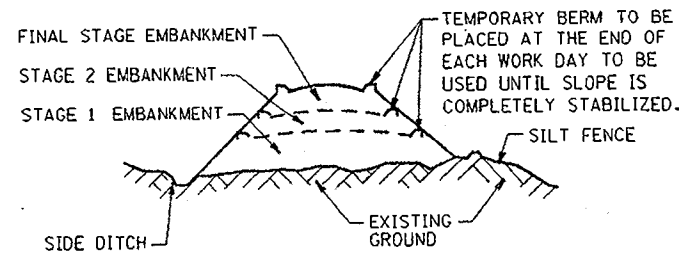

PHASING PLAN-FILL SECTION

CONSTRUCTION SEQUENCE:

1. EXCAVATE AND STABILIZE SIDE DITCHES AND/OR INSTALL PROPOSED CONTROLS AT THE TOES OF SLOPE.
2. PLACE STAGE 1 EMBANKMENT. PLACE TEMPORARY SEEDING AND MULCH, OR TOPSOIL AND PERMANENTLY SEED AND MULCH SLOPE OF THIS STAGE.
3. PLACE STAGE 2 EMBANKMENT. PLACE TEMPORARY SEEDING AND MULCH OR TOPSOIL AND PERMANENTLY SEED AND MULCH SLOPE OF THIS STAGE.
4. PLACE FINAL STAGE EMBANKMENT. PLACE TOPSOIL, PERMANENT SEED AND MULCH ON THE SLOPE THIS STAGE AND ON THE ENTIRE SLOPE IF NOT PREVIOUSLY DONE.

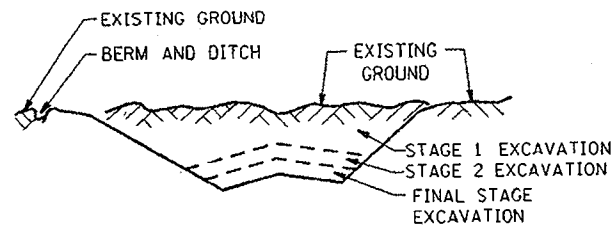

PHASING PLAN-CUT SECTION

CONSTRUCTION SEQUENCE:

1. EXCAVATE AND STABILIZE BERM, SIDE AND OUTLET DITCHES.
2. PERFORM STAGE 1 EXCAVATION. TOPSOIL, PERMANENTLY SEED, AND MULCH SLOPE OF THIS STAGE.
3. PERFORM STAGE 2 EXCAVATION. TOPSOIL, PERMANENTLY SEED, AND MULCH SLOPE OF THIS STAGE.
4. PERFORM FINAL STAGE EXCAVATION. TOPSOIL, PERMANENTLY SEED, AND MULCH SLOPE OF THIS STAGE. REPAIR ANY DAMAGE DONE TO PREVIOUS STAGES.

EMBANKMENT

BEFORE BEGINNING ANY EARTHWORK, EXCAVATE AND STABILIZE SIDE DITCHES AND INSTALL PERIMETER CONTROLS, (SILT FENCE, ETC.). SLOPES GREATER THAN 25 FEET IN HEIGHT SHALL BE EXCAVATED AND STABILIZED IN STAGES OF EQUAL INCREMENTS NOT TO EXCEED 15 FEET.

AT THE END OF EACH WORK DAY TEMPORARY BERMS (EARTH) AND SLOPE DRAINS SHALL BE CONSTRUCTED ALONG THE TOP EDGE(S) OF THE EMBANKMENT TO INTERCEPT SURFACE RUNOFF.

CD-212-3.1

ROADWAY GRADING

	DITCH A (5 AC OR LESS)	DITCH B (5 - 10 AC)
DITCH DEPTH (C)	1'-0"	1'-0"
DITCH WIDTH (D)	4'-0"	6'-0"

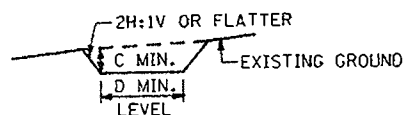

DITCH CROSS SECTION

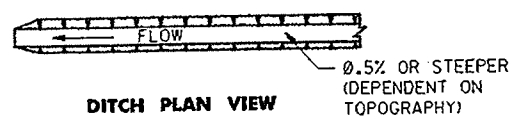

DITCH PLAN VIEW

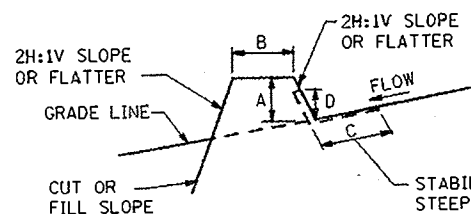

BERM CROSS SECTION

	BERM A (5 AC OR LESS)	BERM B (5 - 10 AC)
BERM HEIGHT (A)	18"	36"
BERM WIDTH (B)	24"	36"
FLOW WIDTH (C)	48"	72"
FLOW HEIGHT (D)	8"	15"

STABILIZATION AS REQUIRED. ON STEEP SLOPES EXCAVATE TO PROVIDE REQUIRED FLOW WIDTH AT FLOW DEPTH.

NOTE:

FIELD LOCATION SHOULD BE ADJUSTED AS NEEDED TO UTILIZE A STABILIZED OUTLET.

STABILIZATION FOR DITCH OR BERM

TYPE OF TREATMENT	GRADE	A - (5 AC OR LESS)	B - (5 - 10 AC)
1	0.5 - 5.0%	SEED USED WITH TOPSOIL STABILIZATION MATTING	SEED USED WITH TOPSOIL STABILIZATION MATTING
2	5.1 - 8.0%	SEED USED WITH TOPSOIL STABILIZATION MATTING	LINED 6"- 9" RIPRAP
3	8.1 - 20.0%	LINED 6"- 9" RIPRAP	ENGINEERED DESIGN

TEMPORARY RUNOFF DIVERSION

CD-212-3.2

1/4" NYLON OR MANILA ROPE FORMS REINFORCEMENT AIDS IN REMOVAL OR RELOCATION OF BARRIER BY SERVING AS A PICK-UP LINE FOR WEIGHTS. ROPES AND WEIGHTS ARE TO BE ATTACHED TO END FLOATS AND EVERY SECOND FLOAT BETWEEN END FLOATS.

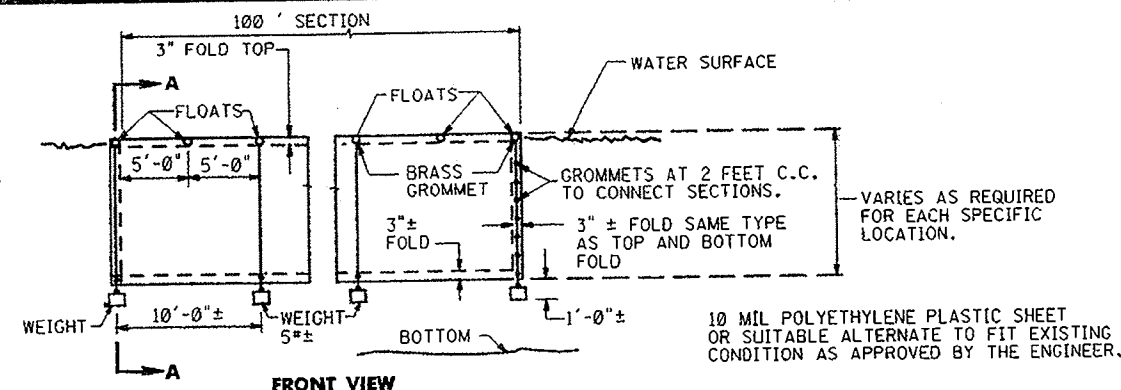

FRONT VIEW

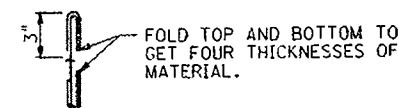

SIDE VIEW FOLDING DETAIL

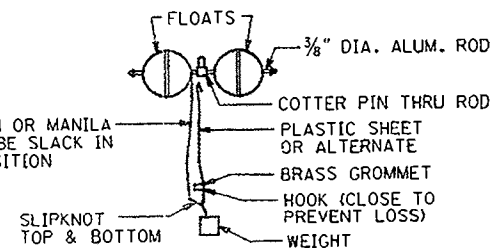

SECTION A-A

NOTE:

SUITABLE ALTERNATE MAY BE FASTENED TO STAKES DRIVEN INTO THE BOTTOM IN LIEU OF FLOATS AND WEIGHTS

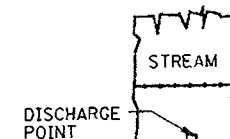

TYPICAL APPLICATION

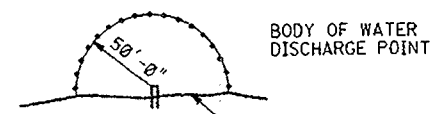

TYPICAL APPLICATION

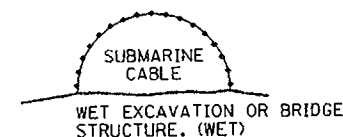

TYPICAL APPLICATION

GENERAL NOTES:

PLACE SILT BARRIER TO PREVENT DRIFTING OF SILT CAUSED BY DISCHARGE OF STORM SEWERS DURING CONSTRUCTION, DREDGING OR FILLING OPERATIONS.

EXACT PLACEMENT OF SILT BARRIER SHALL BE SO AS TO EFFECTIVELY CONTROL SILT DISPERSION UNDER THE CONDITIONS PRESENT ON A PARTICULAR PROJECT.

THE DETAILS SHOWN ON THIS SHEET ARE SUGGESTED METHODS. ONLY ALTERNATE SOLUTION AND USAGE OF MATERIALS MAY BE USED AS APPROVED.

FLOATING TURBIDITY BARRIER

CD-212-3.4

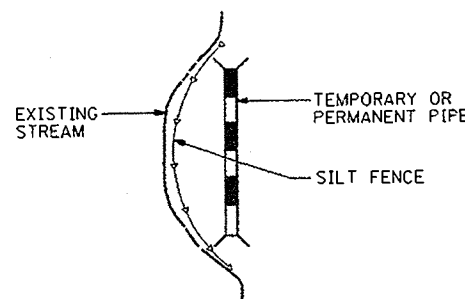

METHOD A PREFERRED

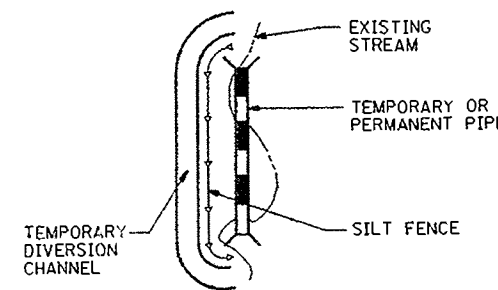

METHOD B

CONSTRUCTION SEQUENCE:

1. INSTALL SILT FENCE ALONG EXISTING STREAM IN AREA OF PROPOSED PIPE CONSTRUCTION.
2. CONSTRUCT PIPE SYSTEM.
3. DIVERT STREAM FLOW INTO PIPE.
4. CONTINUE WITH CONSTRUCTION STAGING.

CONSTRUCTION SEQUENCE:

1. INSTALL SILT FENCE ALONG EXISTING STREAM IN AREA OF TEMPORARY DIVERSION CHANNEL.
2. CONSTRUCT TEMPORARY DIVERSION CHANNEL AND LINE WITH GEOTEXTILE AND TEMPORARY RIPRAP.
3. DIVERT STREAM FLOW INTO TEMPORARY CHANNEL.
4. CONTINUE SEQUENCE FROM STEP 2, METHOD A.

STREAM DIVERSION

CD-212-3.3

TEMPORARY SOIL EROSION AND SEDIMENT CONTROL MEASURES

N.T.S.

CD-212-3

NEW JERSEY DEPARTMENT OF TRANSPORTATION

CONSTRUCTION DETAILS

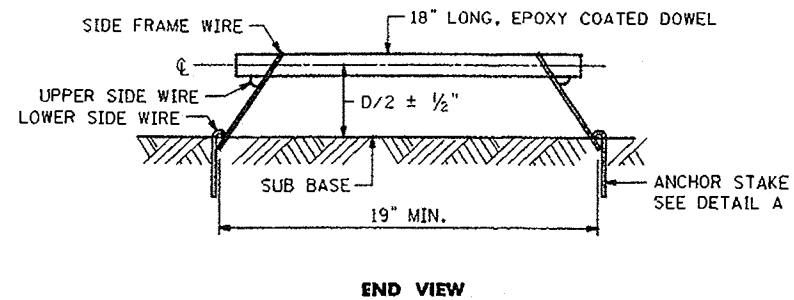
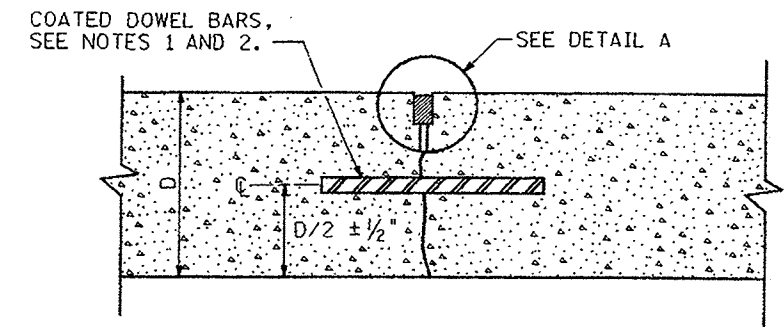
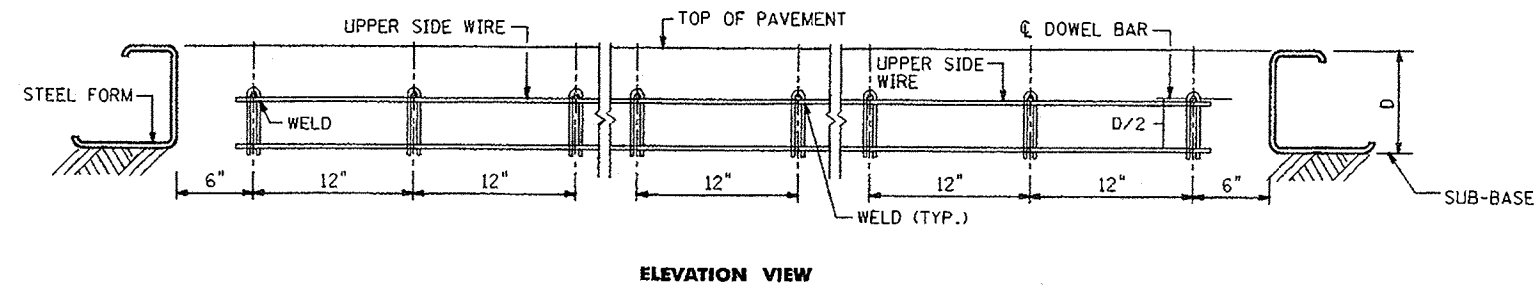
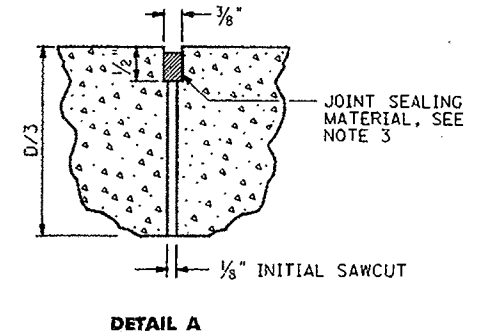
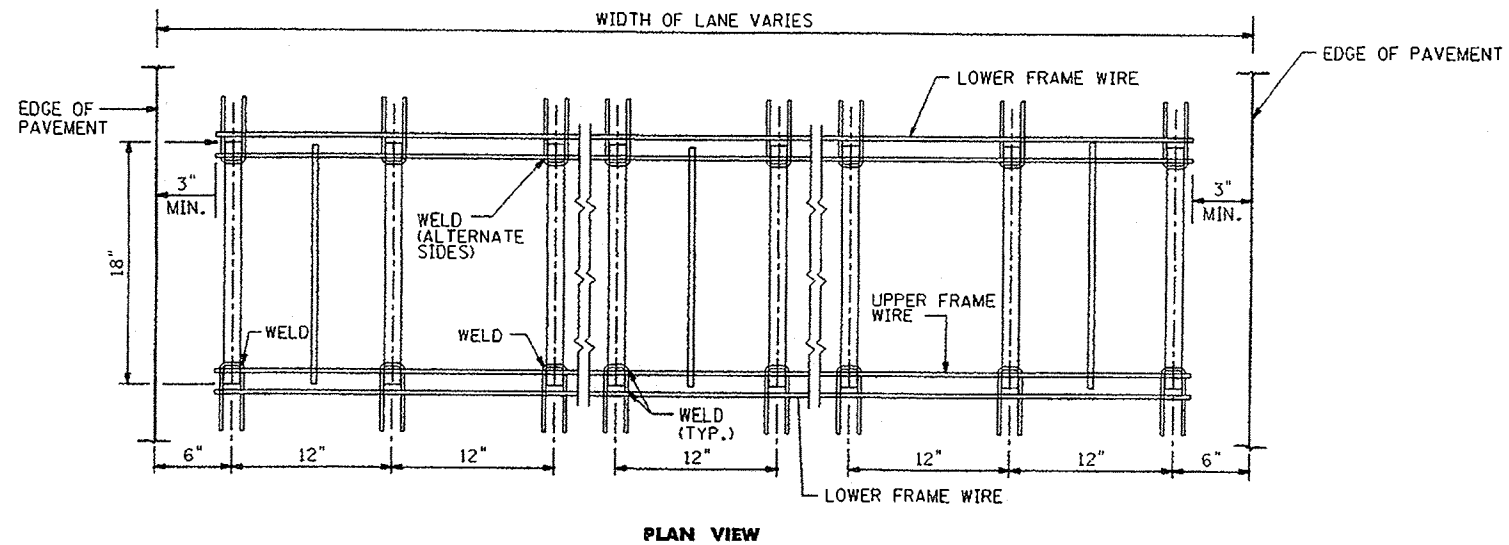

NOTES:

1. PROVIDE A MINIMUM OF EIGHT ANCHOR STAKES (FOUR PER SIDE). ANCHOR STAKES SHALL ENGAGE LOWER SIDE FRAME WIRES. USE ADDITIONAL STAKES AS NECESSARY, TO SECURE ASSEMBLIES, AS DIRECTED BY THE ENGINEER.
2. PROVIDE 12" MINIMUM ANCHOR STAKES TO SECURE ASSEMBLIES WHEN SUBBASE IS USED AND 18" MINIMUM ANCHOR STAKES WHEN AN OPEN GRADED DRAINAGE LAYER IS USED.
3. PROVIDE DOWEL BARS PARALLEL TO THE CENTERLINE AND TO THE PAVEMENT SURFACE. TOLERANCE OF THIS PLACEMENT SHALL BE WITHIN 1/4" PER DOWEL BAR.
4. PROVIDE FRAME SUPPORT ASSEMBLY WIRES CONFORMING TO THE CURRENT ASTM DESIGNATION A-82 SPECIFICATIONS FOR COLD-DRAWN STEEL WIRE FOR CONCRETE REINFORCEMENT AND OF A MINIMUM ALLOWABLE SIZE AS FOLLOWS:

PAVEMENT DEPTHS	UPPER AND LOWER FRAME WIRES	SIDE FRAME WIRES
9" OR LESS	5/16" MIN.	5/16" MIN.
> 9"	7/16" MIN.	7/16" MIN.

TYPICAL LOAD TRANSFER ASSEMBLY		
LANE WIDTH	OVERALL UNIT LENGTH	NO. OF DOWELS
9'-0"	8'-6"	9
10'-0"	9'-6"	10
11'-0"	10'-6"	11
12'-0"	11'-6"	12

NOTES:

1. USE MINIMUM 1/4" X 18" LONG DOWEL BARS FOR PAVEMENT DEPTHS 9" OR LESS. MINIMUM 1/2" X 18" LONG DOWEL BARS FOR PAVEMENT DEPTHS GREATER THAN 9". APPROVED ALTERNATE DOWEL BARS HAVING EQUIVALENT PROPERTIES TO CONVENTIONAL ROUND DOWEL BARS MAY BE USED.
2. PLACE DOWEL BARS PARALLEL TO THE CENTERLINE AND SURFACE OF THE SLAB. THE VERTICAL OR HORIZONTAL SKEW FROM ONE END OF THE DOWEL BAR TO THE OTHER END SHALL NOT EXCEED 1/4".
3. THE TOP OF THE JOINT SEALING MATERIAL SHALL NOT BE LESS THAN 1/16" NOR MORE THAN 3/16" BELOW THE SURFACE OF THE PAVEMENT.
4. THE INITIAL SAWCUT IS NOT REQUIRED FOR TRANSVERSE BUTT JOINTS.

TRANSVERSE CONTRACTION JOINT

CD-306-1.2

CONTRACTION JOINTS IN CONCRETE BASE COURSE

N.T.S.

CD-306-1

NEW JERSEY DEPARTMENT OF TRANSPORTATION

CONSTRUCTION DETAILS

CONTRACTION JOINT ASSEMBLY

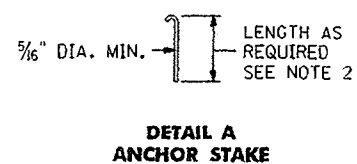
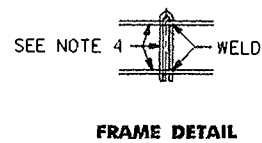

CD-306-1.1

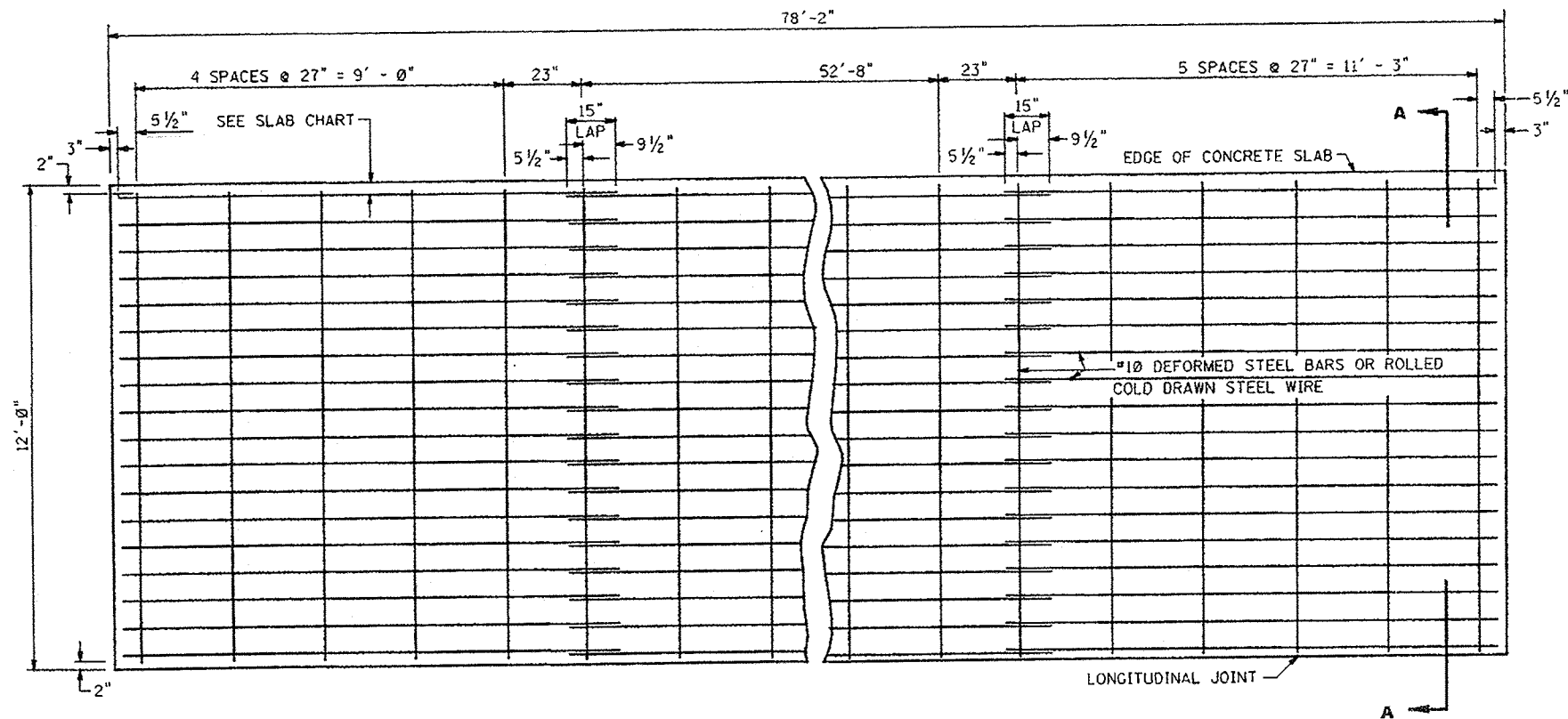

REINFORCEMENT FOR 12'-0" WIDTH SLAB

NOTES:

1. BAR MATS DIFFERING WITH RESPECT TO THEIR LENGTH, SPACING OF TRANSVERSE BARS AND TYPE OF FABRICATION FROM THE MAT SHOWN IN THESE DRAWINGS MAY BE USED, PROVIDED THAT (a) THE MATS HAVE THE SAME SIZE AND SPACING OF LONGITUDINAL BARS, AND PROVIDE AT LEAST THE SAME NUMBER OF TRANSVERSE BARS PER SLAB, AS CALLED FOR IN THESE DRAWINGS, AND (b) APPROVAL FOR USE HAS BEEN OBTAINED FROM THE ENGINEER.

* SEE SLAB CHART

2. ALL BAR MATS SHALL BE FABRICATED ALIKE WITH FIVE (5) TRANSVERSE BARS EXCEPT THE LAST MAT IN EACH SLAB WHICH HAS AN ADDITIONAL TRANSVERSE BAR PLACED 8 1/2" FROM THE TRANSVERSE JOINT.

SLAB CHART FOR THICKNESS LESS THAN 10"														
• WIDTH OF SLAB	3'	4'	5'	6'	7'	8'	9'	10'	11'	12'	13'	14'	15'	16'
NUMBER OF LONGITUDINAL BARS	5	6	8	9	11	13	14	16	17	19	21	22	24	25
SLAB CHART FOR 10" THICKNESS														
• WIDTH OF SLAB	3'	4'	5'	6'	7'	8'	9'	10'	11'	12'	13'	14'	15'	16'
NUMBER OF LONGITUDINAL BARS	6	8	10	12	14	16	18	20	22	24	26	28	30	32

NOTE:

THE EDGE CLEARANCE OF OUTSIDE LOGITUDINAL BARS SHALL BE 3 INCHES IN ALL CASES.

BARS TO BE EVENLY SPACED ACROSS WIDTH OF SLAB WITH A MAXIMUM SPACING OF 7 1/2" FOR SLABS WITH A THICKNESS OF LESS THAN 10" AND 6" FOR SLABS WITH A THICKNESS OF 10".

REINFORCEMENT REQUIREMENTS WHEN USING WELDED STEEL WIRE FABRIC

SLABS LESS THAN 10" THICK:

- LONGITUDINAL WIRE SHALL BE SIZE NO. W8.6 SPACED 6" ON CENTER.
- TRANSVERSE WIRE SHALL BE SIZE NO. W4.7 SPACED 12" ON CENTER.
- EDGE CLEARANCE OF OUTSIDE LONGITUDINAL WIRE SHALL BE 3".
- EDGE CLEARANCE OF THE LAST TRANSVERSE WIRE SHALL NOT BE GREATER THAN 11".
- END CLEARANCE OF THE LONGITUDINAL WIRE SHALL NOT BE LESS THAN 1" NOR MORE THAN 3".
- LONGITUDINAL WIRES SHALL BE LAPPED A MINIMUM OF 12".

SLABS 10" THICK:

- LONGITUDINAL WIRE SHALL BE SIZE NO. W10.5 SPACED 6" ON CENTER.
- TRANSVERSE WIRE SHALL BE SIZE NO. W5.5 SPACED 12" ON CENTER.
- EDGE CLEARANCE OF OUTSIDE LONGITUDINAL WIRE SHALL BE 3".
- EDGE CLEARANCE OF THE LAST TRANSVERSE WIRE SHALL NOT BE GREATER THAN 11".
- END CLEARANCE OF THE LONGITUDINAL WIRE SHALL NOT BE LESS THAN 1" NOR MORE THAN 3".
- LONGITUDINAL WIRES SHALL BE LAPPED A MINIMUM OF 12".

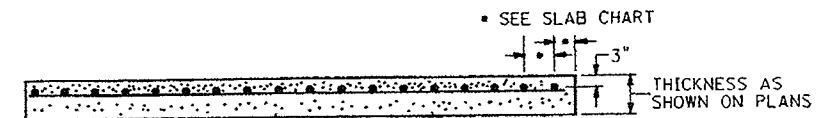

SECTION A-A

GENERAL NOTE:

THE LONGITUDINAL LENGTH OF THE SLAB (78'-2") REFERS TO THE MAXIMUM SLAB DIMENSION WHICH WILL OCCUR AT THE OUTER EDGE OF THE OUTSIDE SLAB ON A CURVE. THE LONGITUDINAL DIMENSION ON THE INNER EDGE OF THIS SLAB AND ADJACENT SLABS WILL VARY IN ORDER TO PROVIDE TRANSVERSE JOINT ALIGNMENT.

NOTE:

REINFORCING BARS ARE IN METRIC UNITS.

CONCRETE SURFACE COURSE

N.T.S.

CONCRETE SURFACE COURSE, REINFORCED _____ " THICK

CD-405-1.1

CD-405-1

NEW JERSEY DEPARTMENT OF TRANSPORTATION

CONSTRUCTION DETAILS

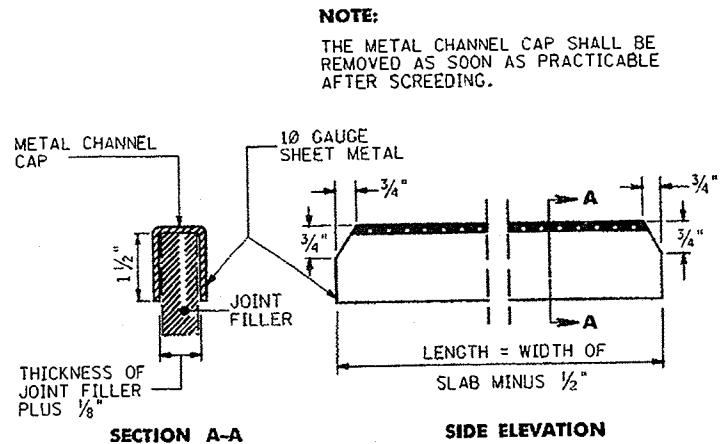

METAL CHANNEL CAP FOR JOINT FILLER

CD-405-2.1

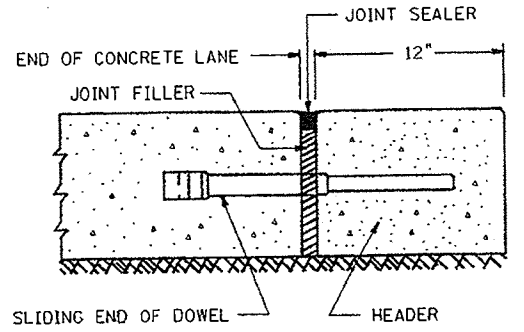

HEADER TO BE CONSTRUCTED AT ENDS OF MAIN TRAFFIC LANES WHERE THE PROPOSED CONCRETE ADJOINS A TEMPORARY TYPE PAVEMENT OTHER THAN CONCRETE AND WHERE IT IS ANTICIPATED THAT THE TEMPORARY PAVEMENT WILL BE REMOVED AND REPLACED WITH CONCRETE.

CONCRETE HEADER

CD-405-2.2

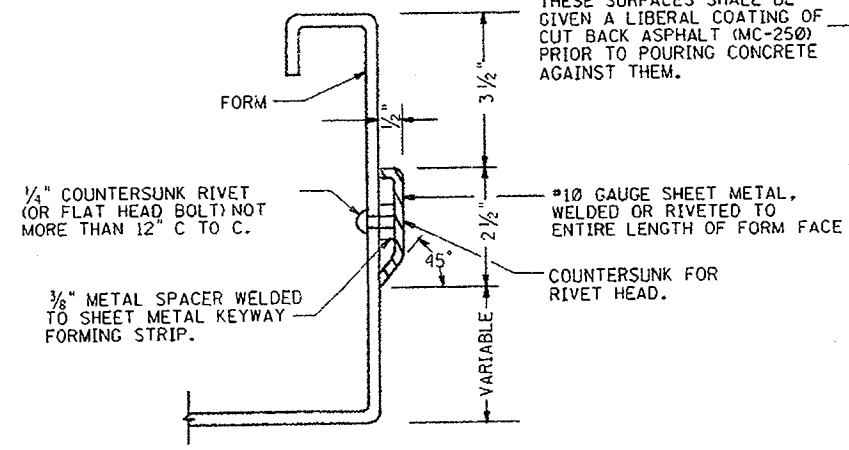

KEYWAY FORMING STRIP

LONGITUDINAL JOINT

THESE SURFACES SHALL BE GIVEN A LIBERAL COATING OF CUT BACK ASPHALT (MC-250) PRIOR TO POURING CONCRETE AGAINST THEM.

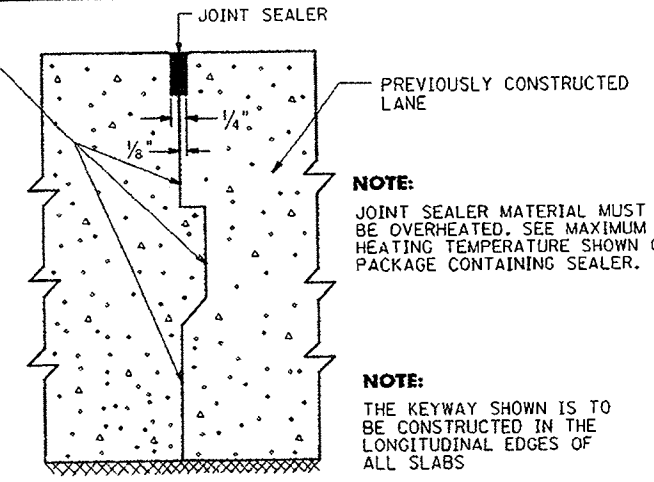

CROSS SECTION OF LONGITUDINAL JOINT

NOTE:
JOINT SEALER MATERIAL MUST NOT BE OVERHEATED. SEE MAXIMUM SAFE HEATING TEMPERATURE SHOWN ON PACKAGE CONTAINING SEALER.

NOTE:
THE KEYWAY SHOWN IS TO BE CONSTRUCTED IN THE LONGITUDINAL EDGES OF ALL SLABS

CD-405-2.3

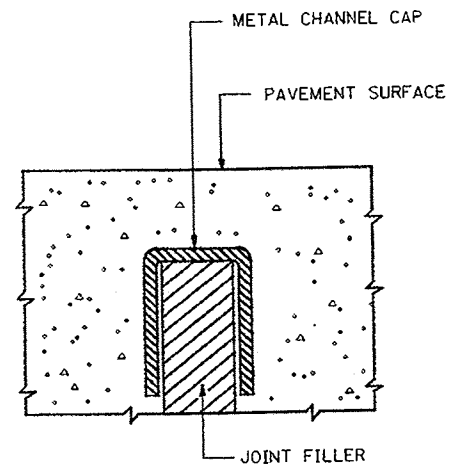

TOP OF JOINT FILLER PROTECTED BY THE METAL CHANNEL CAP DURING THE PLACING OF THE CONCRETE AND OPERATION OF THE FINISHING MACHINES. THE CAP SHALL BE REMOVED AS SOON AS PRACTICAL AFTER THE FINAL PASSAGE OF THE FINISHING MACHINES.

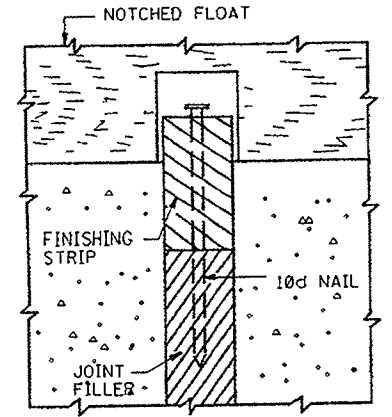

AFTER REMOVAL OF THE CAP, THE FINISHING STRIP IS TO BE CENTERED DIRECTLY OVER THE JOINT FILLER AND NAILED SECURELY THERETO. AFTER THE REPLACEMENT OF THE DISTURBED CONCRETE, THE PAVEMENT SURFACE IS TO BE FINISHED TO THE PROPER GRADE BY MEANS OF A NOTCHED FLOAT.

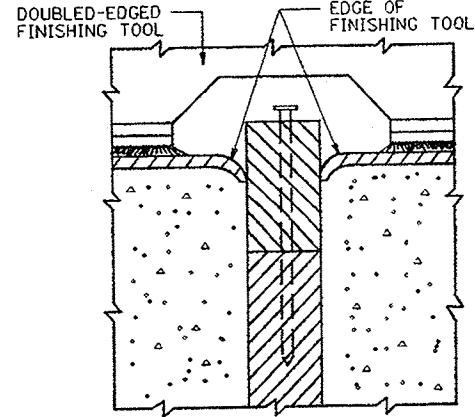

AFTER THE CONCRETE HAS SET SUFFICIENTLY, AND AFTER SURFACE TEXTURING, THE CONCRETE AT THE JOINT SHALL BE LIGHTLY EDGED AND FINISHED WITH A DOUBLE-EDGED TOOL. THE FINISHING STRIP IS TO REMAIN IN PLACE UNTIL IMMEDIATELY PRIOR TO SEALING THE JOINT.

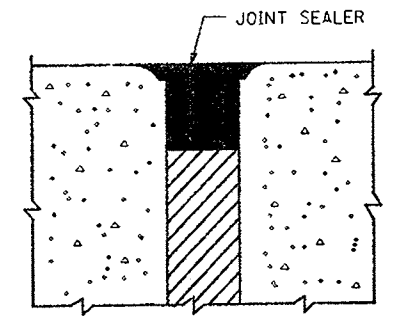

PROCEDURE TO BE FOLLOWED IN THE EDGING AND FINISHING OF ALL TRANSVERSE JOINTS

CD-405-2.4

3" x 3" ANGLE OF 12 GAUGE THICK SHEET METAL PLACED TO PROTECT THE JOINT FILLER AGAINST THE ACTION OF THE FINISHING SCREEN CAN BE ANY LENGTH.

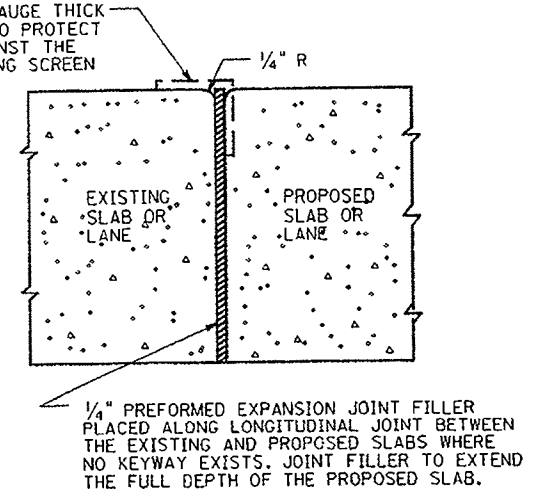

METHOD OF CONSTRUCTION LONGITUDINAL JOINT WHERE NO KEYWAY EXISTS

CD-405-2.5

CONCRETE SURFACE COURSE JOINT DETAILS

N.T.S.

CD-405-2

NEW JERSEY DEPARTMENT OF TRANSPORTATION

CONSTRUCTION DETAILS

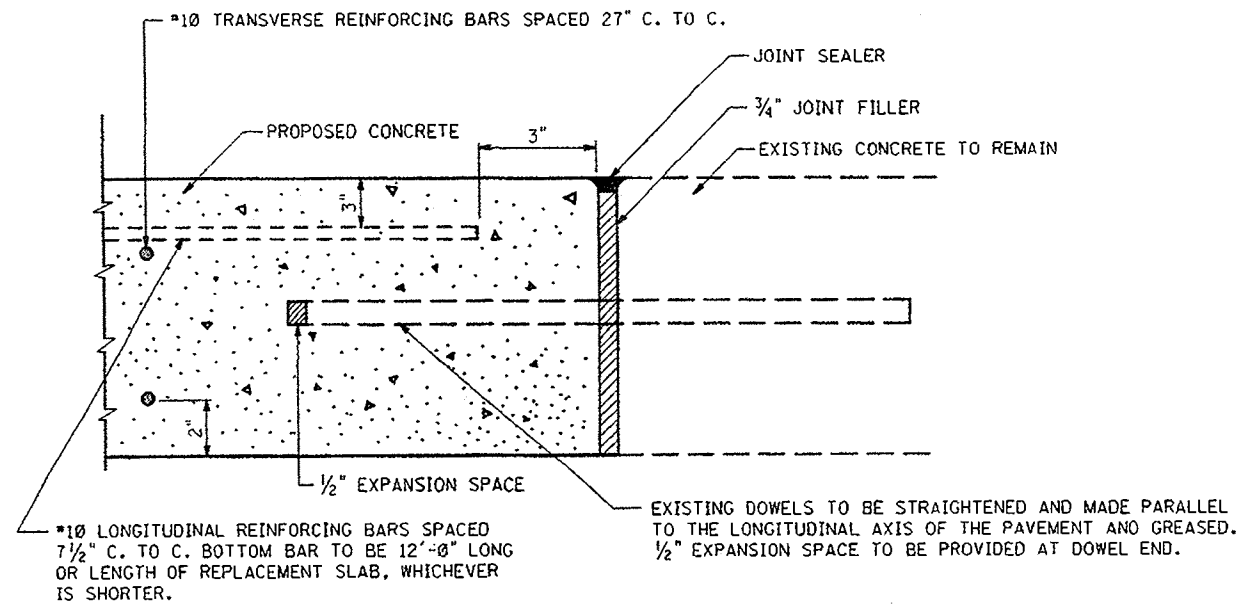

DETAILS OF JOINT BETWEEN EXISTING CONCRETE TO REMAIN AND PROPOSED CONCRETE

CD-405-3.1

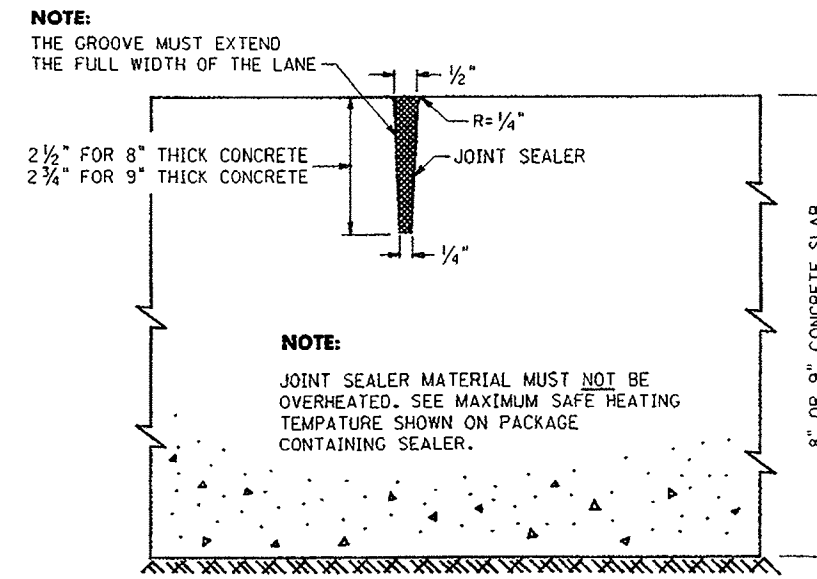

CONTRACTION JOINTS TO BE INSTALLED IN CONCRETE AT INTERVALS OF 15 FEET

DETAIL OF CONTRACTION JOINT FOR NON-REINFORCED CONCRETE SURFACE COURSE

CD-405-3.3

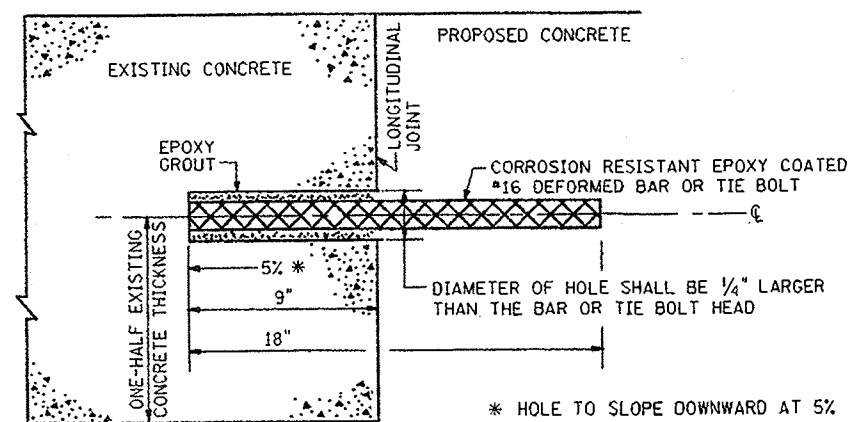

NOTE:
THE TIES SHALL BE SPACED 36 INCHES CENTER TO CENTER. TIES SHALL NOT BE PLACED WITHIN TWO (2) FEET OF A TRANSVERSE EXPANSION OR CONTRACTION JOINT. WHEN A TIE WILL FALL WITHIN ONE (1) FOOT OF A CRACK EXTENDING THROUGH THE FULL DEPTH OF THE EXPOSED EDGE OF THE EXISTING CONCRETE IT SHALL BE MOVED LATERALLY OR OMITTED AT THE DIRECTION OF THE ENGINEER.

LONGITUDINAL JOINT TIE FOR NARROW WIDTH WIDENING

CD-405-3.2

NOTE:
REINFORCING BARS ARE IN METRIC UNITS.

CONCRETE SURFACE COURSE JOINT DETAILS

N.T.S.

CD-405-3

NEW JERSEY DEPARTMENT OF TRANSPORTATION

CONSTRUCTION DETAILS

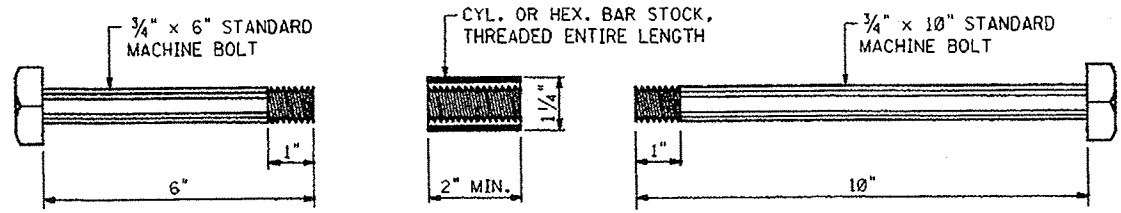

DETAIL OF PARTS

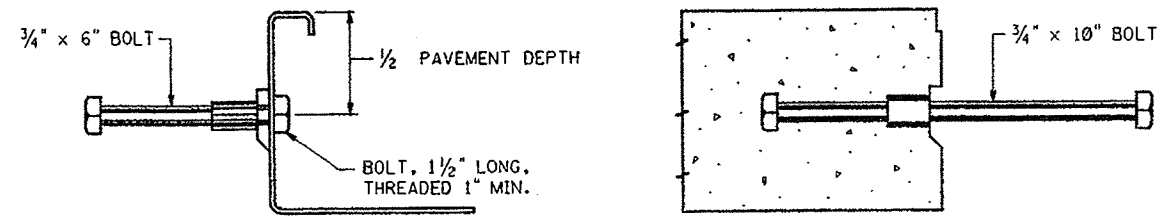

SKETCH SHOWING ATTACHMENT TO FORM

SKETCH SHOWING COMPLETE INSTALLATION

TIE BOLT ASSEMBLY

CD-405-4.1

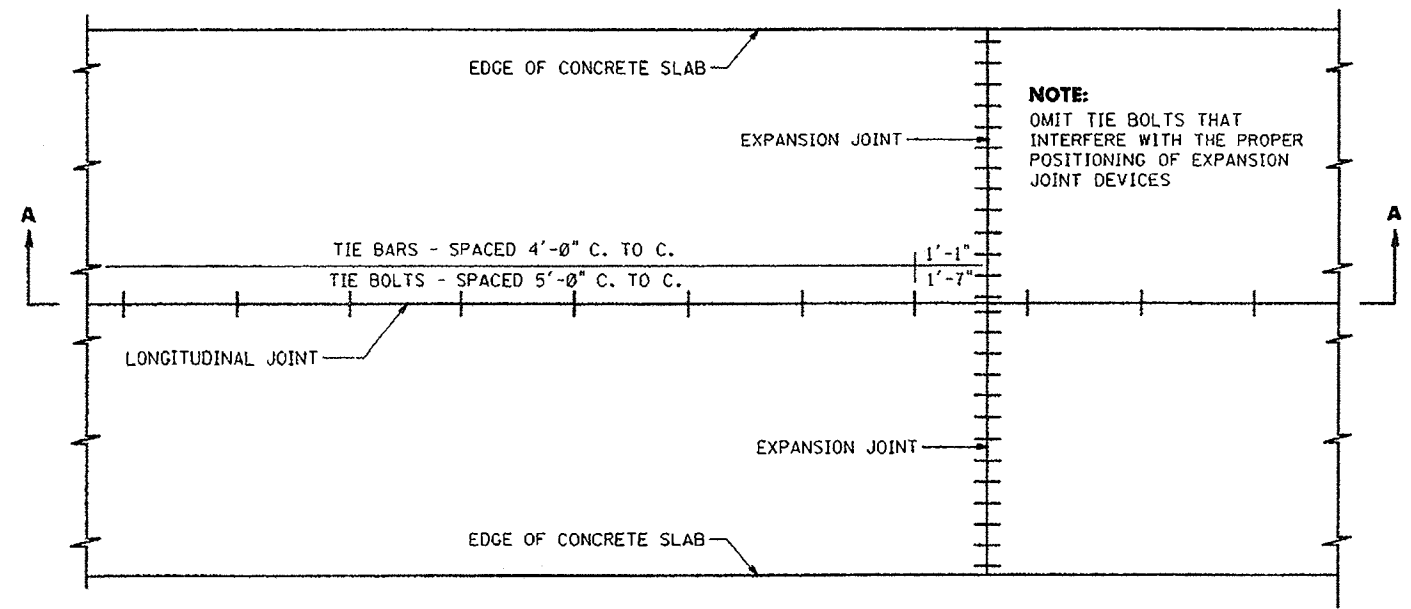

LOCATION OF TIE BOLTS OR TIE BARS IN CONCRETE SURFACE COURSE

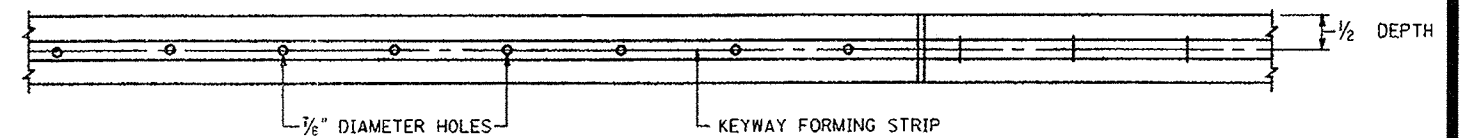

SECTION A-A

NOTES:

IN THE CASE OF FOUR ADJACENT LANES, TIES ARE TO BE OMITTED ALONG THE LONGITUDINAL JOINT BETWEEN THE INNER LANES. UNDER ANY OTHER CONDITIONS, NO MORE THAN THREE ADJACENT LANES ARE TO BE CONNECTED BY TIES.

TIES SHALL BE OMITTED IN TRANSITION PAVEMENT AND BRIDGE APPROACH SLABS.

WHEN TWO ADJACENT LANES OF CONCRETE ARE CONSTRUCTED IN A SINGLE OPERATION, TIE BARS, CONSISTING OF NO. 5 STRAIGHT BARS OF REINFORCING STEEL, 36 INCHES LONG, SHALL BE INSTALLED BETWEEN THE LANES AND POSITIONED SUCH THAT THEY WILL BE CENTERED ON A LONGITUDINAL JOINT AND AT RIGHT ANGLES THERETO, AND MIDWAY BETWEEN THE TOP AND BOTTOM OF THE CONCRETE COURSE.

TIE BOLTS AND TIE BARS

N.T.S.

CD-405-4

NEW JERSEY DEPARTMENT OF TRANSPORTATION

CONSTRUCTION DETAILS

CD-405-4.2

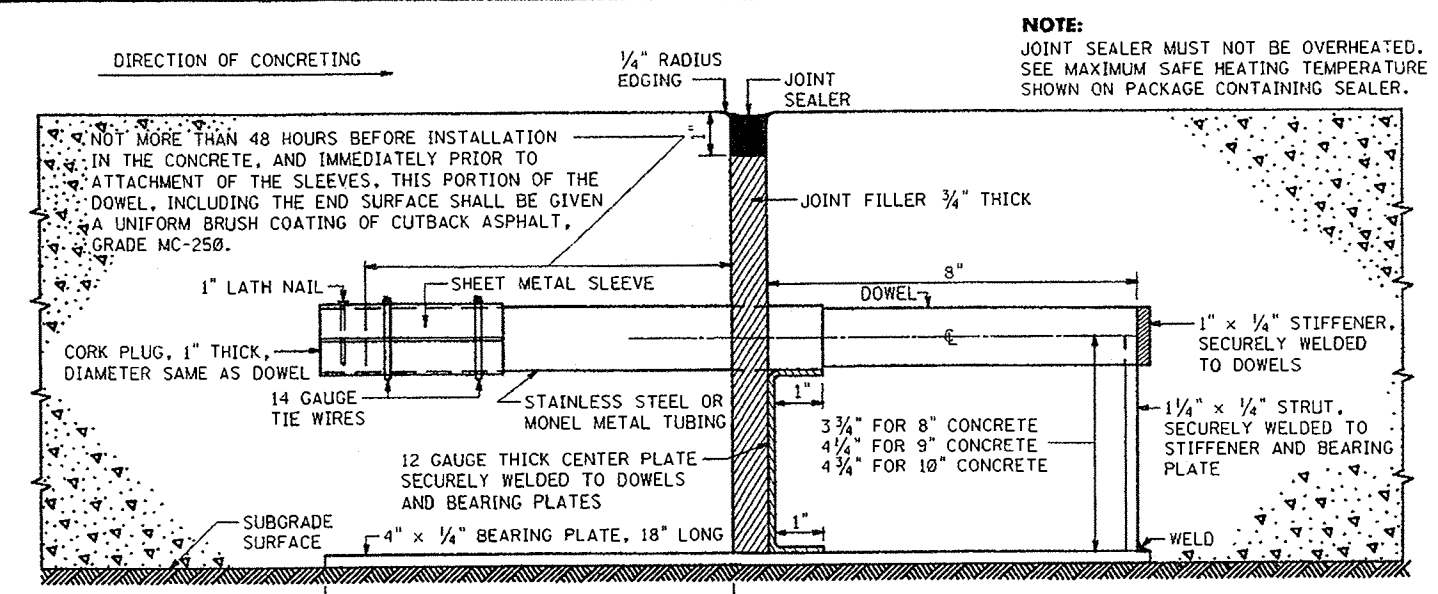

NOTE: THE TOP SURFACE AND EDGES OF THIS PORTION OF THE BEARING PLATE SHALL BE GIVEN A LIBERAL BRUSH COATING OF HEAVY OIL OR GREASE IMMEDIATELY PRIOR TO CONCRETING.

TYPICAL CROSS SECTION

NOTE: THE DOWELS SHALL BE PARALLEL WITH EACH OTHER, PARALLEL WITH THE BEARING PLATES, AND PERPENDICULAR TO THE CENTER PLATE.

NOTES:
 USE STAINLESS STEEL WELDING ROD TUBING WELD (MADE WITH STAINLESS STEEL) AND NO. 140 MONEL ROD IF TUBING IS MONEL.
 THE HEIGHT OF THE STEEL SPACER EQUALS THE DISTANCE FROM THE BEARING PLATE TO THE C OF THE DOWEL MINUS HALF OF THE DOWEL DIAMETER LESS THE 1/4" ANGLE.

- 2'-0" FOR 4'-0" JOINTS
- 4'-0" FOR 6'-0" JOINTS (NO BEARING PLATE AT CENTER)
- 6'-0" FOR 8'-0" JOINTS
- 4'-0" FOR 10'-0" JOINTS
- 5'-0" FOR 12'-0" JOINTS
- 6'-0" FOR 14'-0" JOINTS

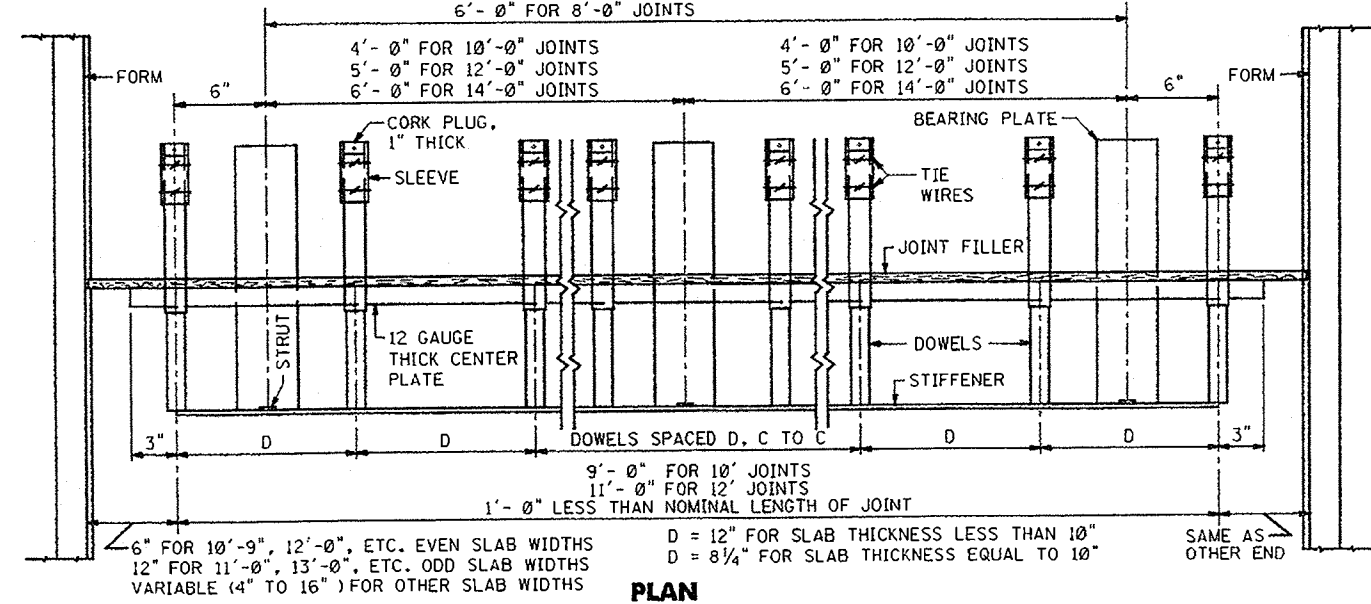

PLAN

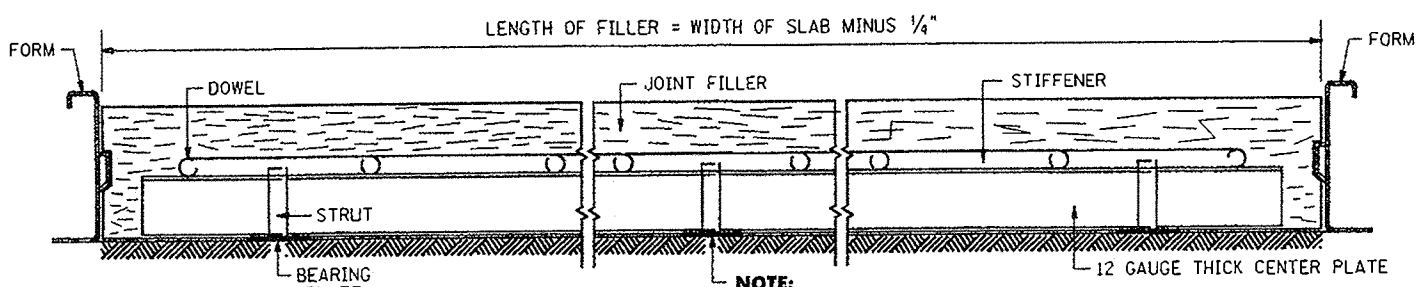

ELEVATION

NOTE:
 USE 4'-0" JOINTS FOR SLAB WIDTHS BETWEEN 3'-8" AND 5'-8"
 USE 6'-0" JOINTS FOR SLAB WIDTHS BETWEEN 5'-8" AND 7'-8"
 USE 8'-0" JOINTS FOR SLAB WIDTHS BETWEEN 7'-8" AND 9'-8"
 USE 10'-0" JOINTS FOR SLAB WIDTHS BETWEEN 9'-8" AND 11'-8"
 USE 12'-0" JOINTS FOR SLAB WIDTHS BETWEEN 11'-8" AND 13'-8"
 USE 14'-0" JOINTS FOR SLAB WIDTHS BETWEEN 13'-8" AND 15'-8"

CD-405-5.1

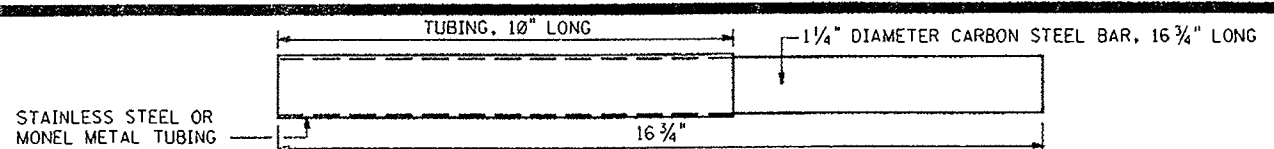

DOWEL SPECIFICATIONS

THE DOWELS SHALL CONSIST OF EITHER (a) 1/4 INCH DIA. SOLID STAINLESS STEEL BARS, (b) 1/4 INCH DIA. CARBON STEEL BARS ENCASED IN STAINLESS STEEL OR MONEL METAL, OR (c) 1/4 INCH DIA. CARBON STEEL BARS THAT HAVE BEEN IMPREGNATED WITH CHROMIUM THROUGHOUT THEIR EXPOSED SURFACE. THE STAINLESS STEEL SHALL CONTAIN NOT LESS THAN 12 PERCENT CHROMIUM, IF ENCASED IN STAINLESS STEEL OR MONEL METAL, THE THICKNESS OF THE STAINLESS STEEL OR MONEL METAL SHALL NOT BE LESS THAN .01 INCHES, AND THE TIGHTNESS OF FIT SHALL BE SUCH AS TO PRECLUDE THE OCCURRENCE OF CORROSION BETWEEN THE STAINLESS STEEL OR MONEL METAL AND THE UNDERLYING CARBON STEEL. IF RENDERED CORROSION-RESISTANT BY IMPREGNATION WITH CHROMIUM, THE LAYER OF METAL WHICH HAS BEEN SO IMPREGNATED SHALL HAVE (a) AN AVERAGE THICKNESS OF NOT LESS THAN .009 INCH, (b) AT NO POINT

A THICKNESS OF LESS THAN .008 INCH, AND (c) AN AVERAGE CHROMIUM CONTENT OF NOT LESS THAN 20 PERCENT, BY WEIGHT. THE CONTRACTOR SHALL FURNISH THE ENGINEER WITH A CERTIFICATION SHOWING THAT THE MEANS EMPLOYED FOR RENDERING THE DOWELS CORROSION-RESISTANT COMPLIES WITH THE FOREGOING SPECIFICATIONS.

THE DOWELS SHALL NOT VARY IN STRAIGHTNESS THROUGHOUT THEIR LENGTH IN EXCESS OF 1/32 INCH. THE SLIDING PORTION OF THE DOWEL SHALL BE OF UNIFORM CROSS SECTION, FREE FROM BURRS, PROJECTIONS, AND ANY OTHER IRREGULARITIES THAT WOULD INTERFERE WITH FREE MOVEMENT IN THE CONCRETE.

CD-405-5.2

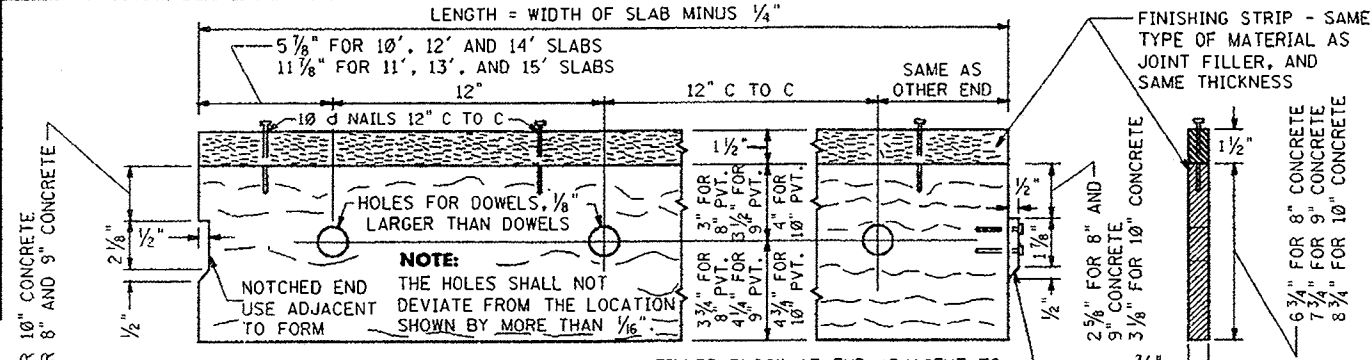

SIDE ELEVATION

CROSS SECTION

NOTE: THE FINISHING STRIP SHALL BE ATTACHED AFTER THE REMOVAL OF THE METAL CHANNEL CAP, AND SHALL BE CENTERED DIRECTLY OVER THE FILLER AND NAILED SECURELY THERETO, AS SHOWN. IF DESIRED, THE STRIP MAY CONSIST OF TWO PIECES, OF EQUAL LENGTH, INSTALLED END TO END. THE FINISHING STRIP SHALL NOT BE REMOVED UNTIL IMMEDIATELY PRIOR TO SEALING THE JOINT WITH HOT-POURED RUBBER-ASPHALT.

NOTE: THE FILLER SHALL BE SUPPORTED BY MEANS OF STEEL PINS, 1 INCH IN DIAMETER, DRIVEN ON BOTH SIDES OF THE FILLER. THE PINS SHALL BE OF ADEQUATE LENGTH AND SUFFICIENT NUMBER TO INSURE THAT THE FILLER WILL BE HELD SECURELY IN ITS PROPER POSITION, AND THEY SHALL NOT BE REMOVED UNTIL AFTER THE FINAL PASSAGE OF THE FINISHING MACHINES.

DETAILS OF JOINT FILLER

CD-405-5.3

ALTERNATIVE JOINT DEVICES

- ALTERNATIVE TRANSVERSE JOINT DEVICES SHALL COMPLY WITH THE REQUIREMENTS OF THE SPECIFICATIONS FOR TRANSVERSE EXPANSION JOINTS AND WITH THE FOLLOWING:
1. THE LOAD-TRANSFERRING CAPACITY OF THE DEVICE SHALL BE SUCH THAT, WHEN TESTED IN ACCORDANCE WITH THE PROCEDURE CURRENTLY IN USE BY THE DEPARTMENT, THE DEVICE SHALL BE CAPABLE OF TRANSFERRING A LOAD OF 10,000 POUNDS PER LINEAR FOOT OF JOINT ACROSS A SPACE 1 1/2 INCHES IN WIDTH WITH A DEFLECTION OF NOT MORE THAN .05 INCH.
 2. THE TOTAL RANGE OF RELATIVE VERTICAL MOVEMENT OF ADJACENT SLAB ENDS WHICH THE DEVICE WILL PERMIT PRIOR TO POSITIVE ENGAGEMENT OF THE LOAD-TRANSFERRING ELEMENTS SHALL NOT EXCEED .01 INCH.
 3. THE DESIGN OF THE DEVICE SHALL BE SUCH THAT THE JOINT SPACE MAY BECOME AT LEAST 3/4 INCH WIDER OR NARROWER THAN ITS CONSTRUCTED WIDTH. THE RESISTANCE TO OPENING OF THE JOINT, PER LINEAR FOOT, SHALL NOT EXCEED (a) 500 POUNDS THROUGHOUT THE TOTAL RANGE OF MOVEMENT AND (b) 200 POUNDS FOR AN INITIAL OPENING OF .10 INCH.
 4. THE DEVICE SHALL BE CAPABLE OF RESISTING ALL NORMAL FORCES IMPOSED DURING SHIPMENT, HANDLING, INSTALLATION AND ALL CONCRETING OPERATIONS. THE RIGIDITY AND STRENGTH OF THE DEVICE SHALL BE SUCH THAT,

AFTER ASSEMBLY, A 200 POUND PERSON MAY APPLY HIS FULL WEIGHT TO ANY PART OR PARTS THEREOF WITHOUT CAUSING PERMANENT DEFORMATION OR DISPLACEMENT. THE DESIGN OF THE DEVICE SHALL BE SUCH THAT AFTER THE PAVEMENT HAS BEEN CONSTRUCTED, AND REGARDLESS OF WHETHER THE SUBGRADE IS FIRM OR SUBJECT TO DISPLACEMENT, ALL SLIDING SURFACES WILL BE PARALLEL WITH THE LONGITUDINAL AXIS OF THE PAVEMENT WITHIN A TOLERANCE OF ONE DEGREE, AND PARALLEL WITH RESPECT OF EACH OTHER WITHIN A TOLERANCE OF ZERO DEGREES, FORTY-FIVE MINUTES.

5. ALL PARTS OF THE JOINT DEVICE, THE CORROSION OF WHICH WOULD RESULT IN RESTRAINT OR A REDUCTION IN LOAD-TRANSFERRING CAPACITY, SHALL BE (a) COMPOSED OF SOLID STAINLESS STEEL, (b) ENCASED IN STAINLESS STEEL OR MONEL METAL OR (c) IMPREGNATED WITH CHROMIUM THROUGHOUT THEIR EXPOSED SURFACES. THE COMPOSITION OF THE STAINLESS STEEL, THICKNESS OF ENCASEMENT, AND REQUIREMENTS FOR IMPREGNATION WITH CHROMIUM SHALL ALL BE AS SPECIFIED ABOVE UNDER "DOWEL SPECIFICATIONS".

CD-405-5.4

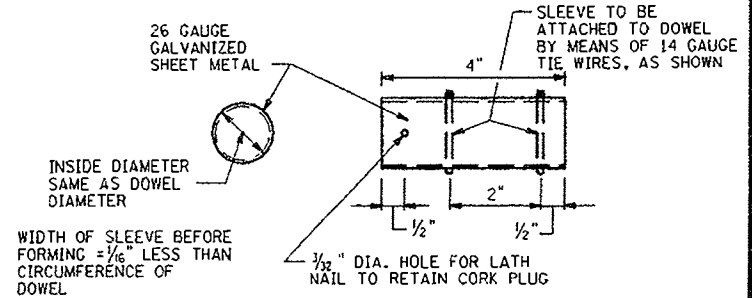

NOTE: SLEEVES OR END CAPS OF OTHER DESIGN MAY BE SUBMITTED FOR APPROVAL. THEY SHALL FIT CLOSELY AROUND THE DOWEL AND SHALL BE DESIGNED SO AS TO POSITIVELY PREVENT THE ENTRANCE OF MORTAR INTO THE 1 INCH SPACE TO BE PROVIDED AT THE END OF THE DOWEL.

DETAILS OF SHEET METAL SLEEVES

CD-405-5.5

TRANSVERSE EXPANSION JOINT TYPE A

N.T.S.

CD-405-5

NEW JERSEY DEPARTMENT OF TRANSPORTATION

CONSTRUCTION DETAILS

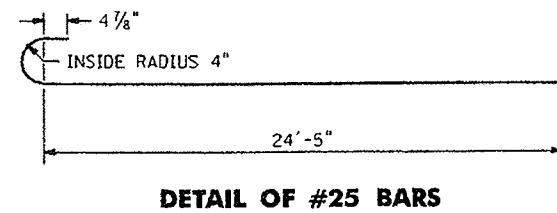
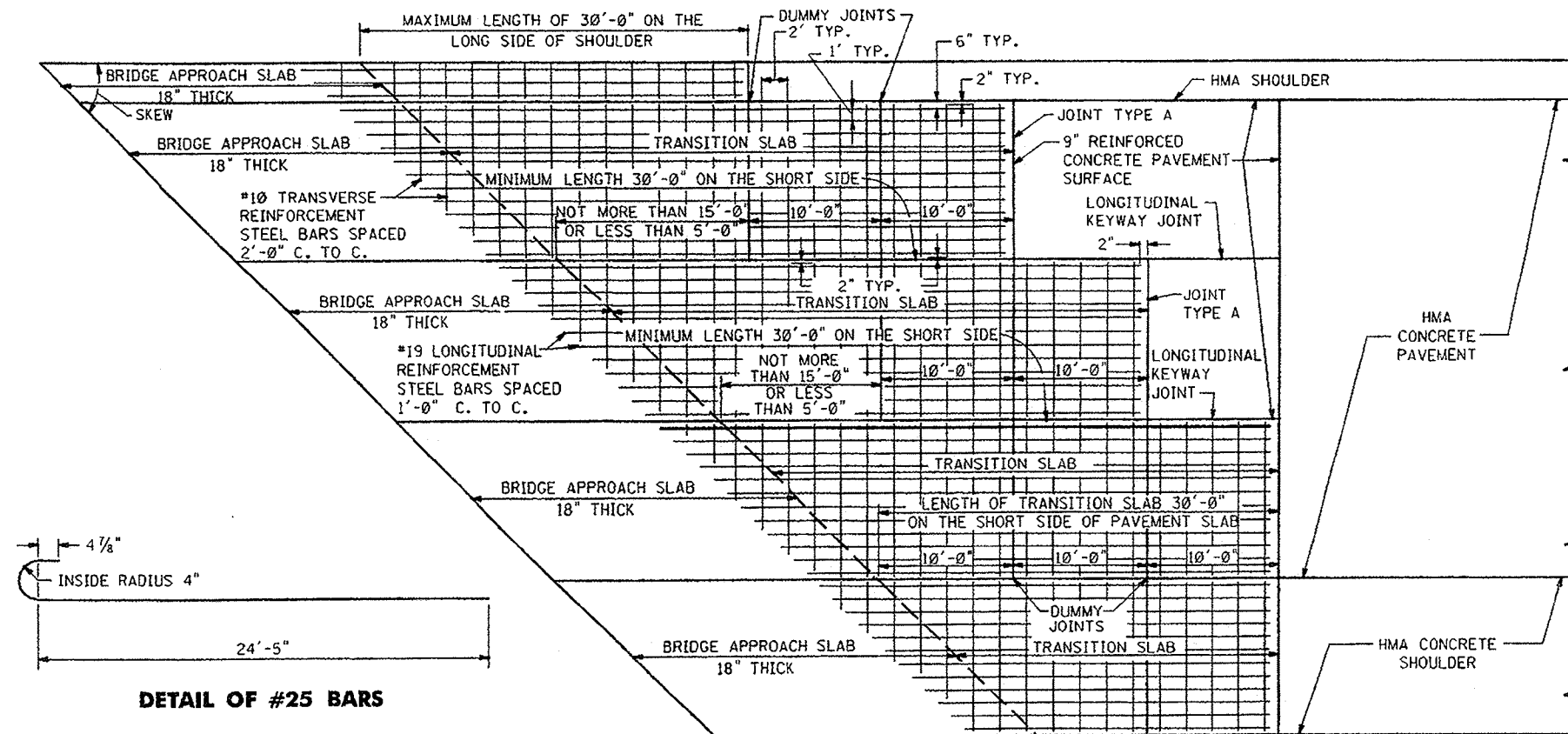

PLAN OF TRANSITION SLABS BETWEEN HMA CONCRETE PAVEMENT AND BRIDGE APPROACH SLABS

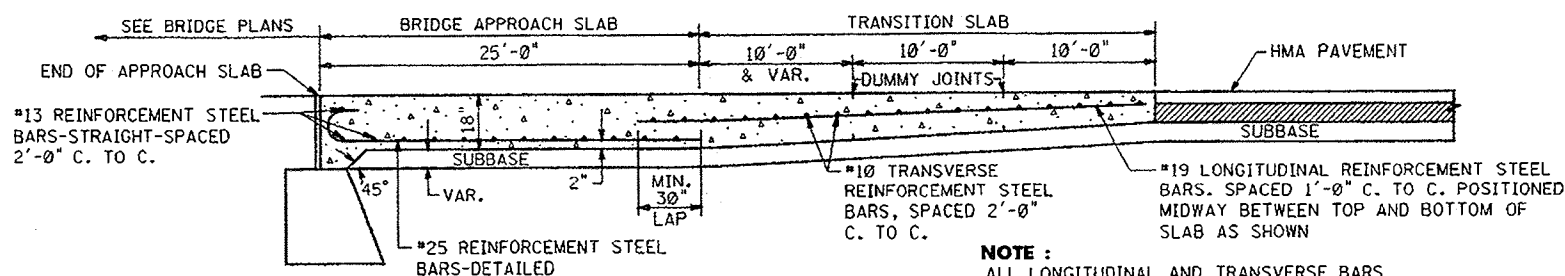

SECTION OF TRANSITION SLABS BETWEEN HMA CONCRETE PAVEMENT AND BRIDGE APPROACH SLABS

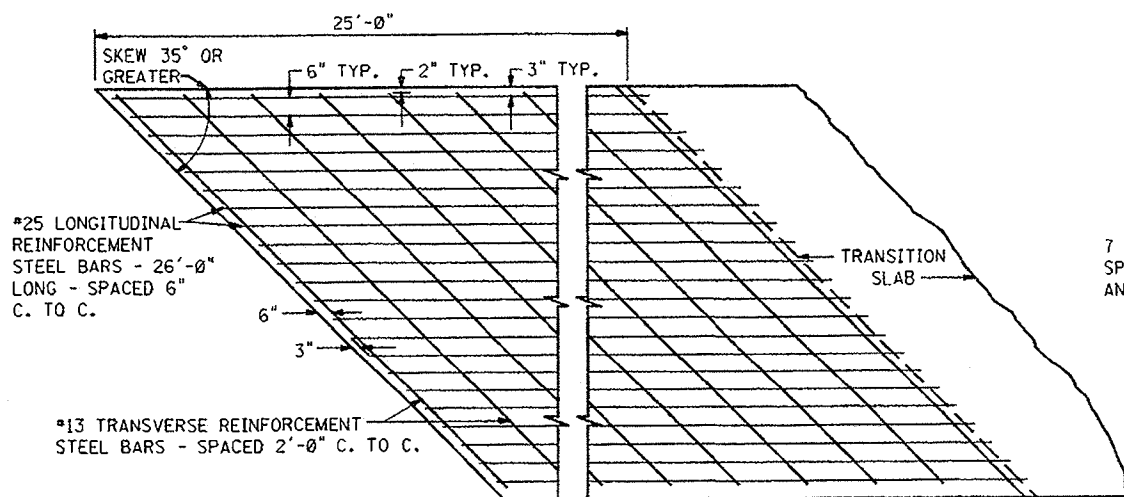

DETAIL FOR BRIDGE APPROACH SLABS WHEN SKEW ANGLE IS 35° OR GREATER

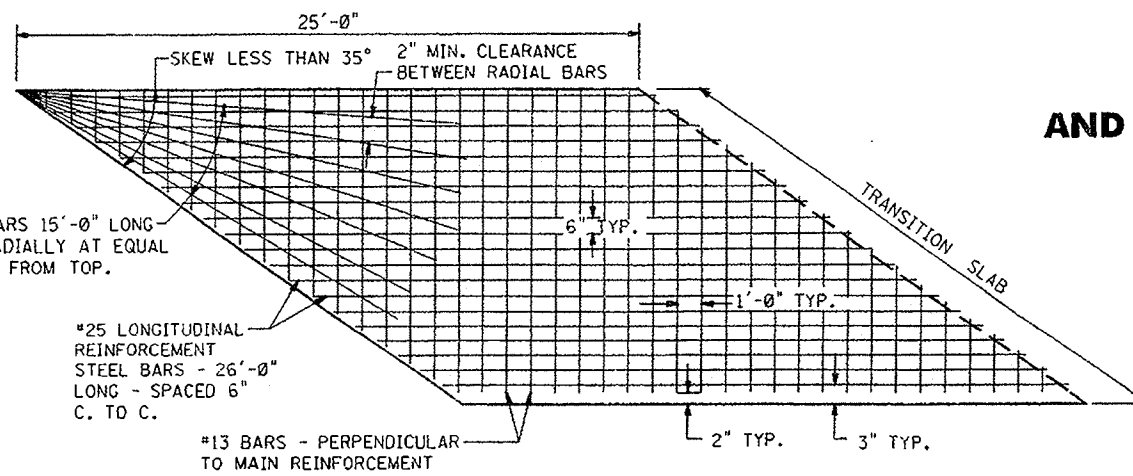

DETAIL FOR BRIDGE APPROACH SLABS WHEN SKEW ANGLE IS LESS THAN 35°

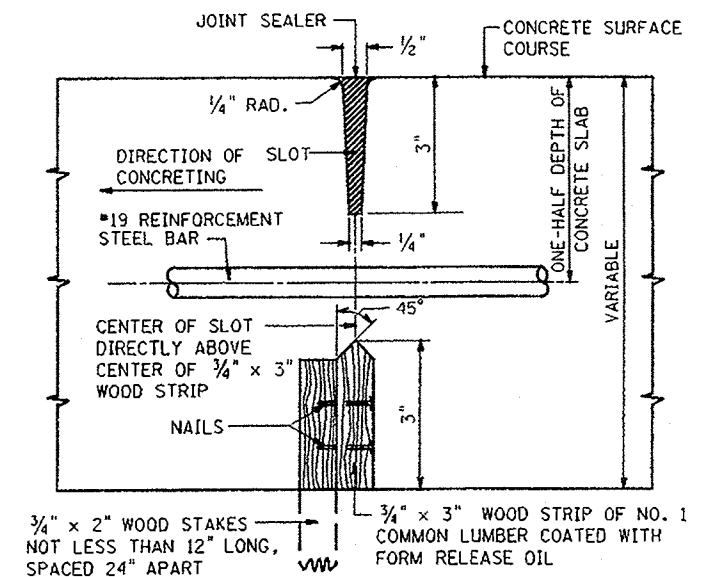

DETAIL OF DUMMY JOINT

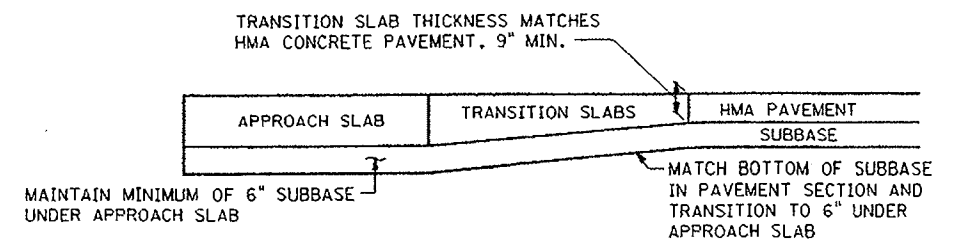

TYPICAL SECTION FOR SUBBASE UNDER APPROACH AND TRANSITION SLABS

NOTE :
IF WATER IS POCKETED, INSTALL OUTLET TRENCH AT LOW POINT.

NOTES:
REINFORCING BARS ARE IN METRIC UNITS.
HMA = HOT ASPHALT MIX

BRIDGE APPROACH SLABS AND TRANSITION SLABS ADJOINING HMA CONCRETE PAVEMENT

N.T.S.

CD-405-6

NEW JERSEY DEPARTMENT OF TRANSPORTATION

CONSTRUCTION DETAILS

pen table = /acodeproulez_piorfabioaaf-ictab.tbl
 scale = .
 queue = .
 date = .
 file = .
 D = .

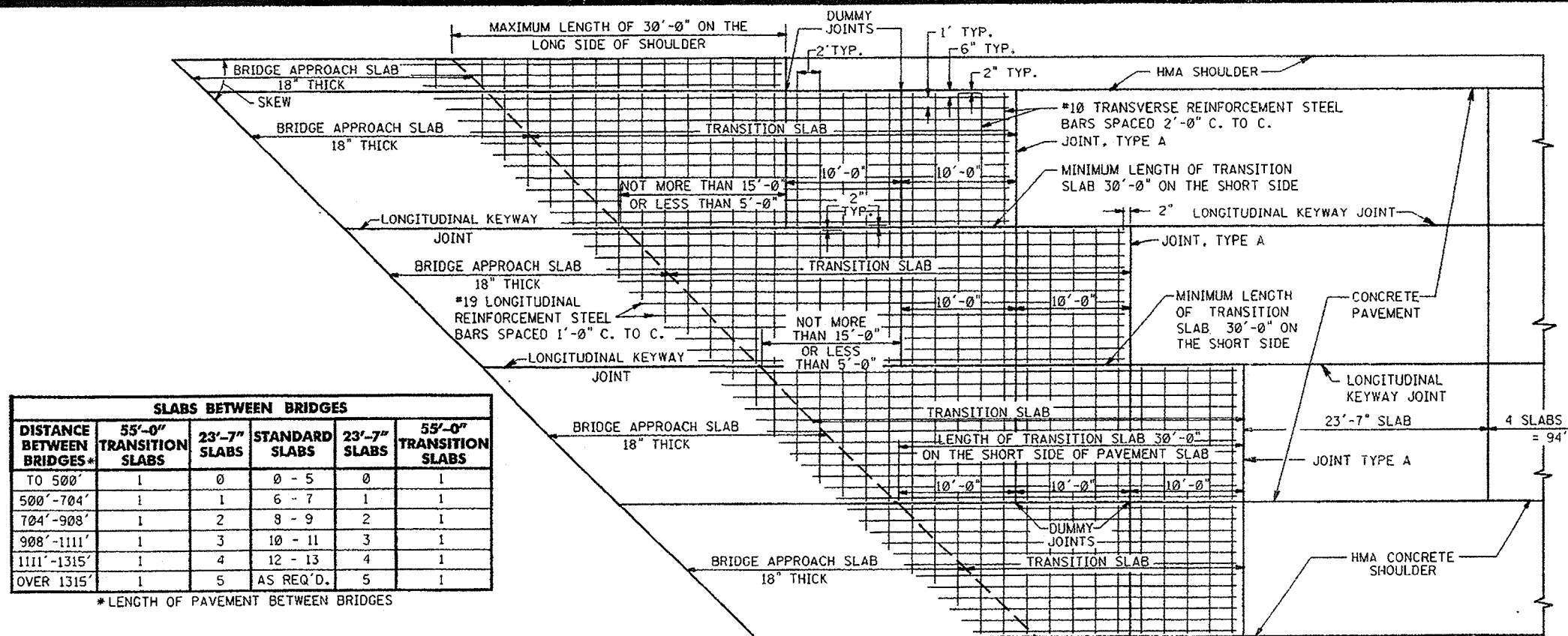

SLABS BETWEEN BRIDGES					
DISTANCE BETWEEN BRIDGES*	55'-0" TRANSITION SLABS	23'-7" SLABS	STANDARD SLABS	23'-7" SLABS	55'-0" TRANSITION SLABS
TO 500'	1	0	0 - 5	0	1
500'-704'	1	1	6 - 7	1	1
704'-908'	1	2	8 - 9	2	1
908'-1111'	1	3	10 - 11	3	1
1111'-1315'	1	4	12 - 13	4	1
OVER 1315'	1	5	AS REQ'D.	5	1

*LENGTH OF PAVEMENT BETWEEN BRIDGES

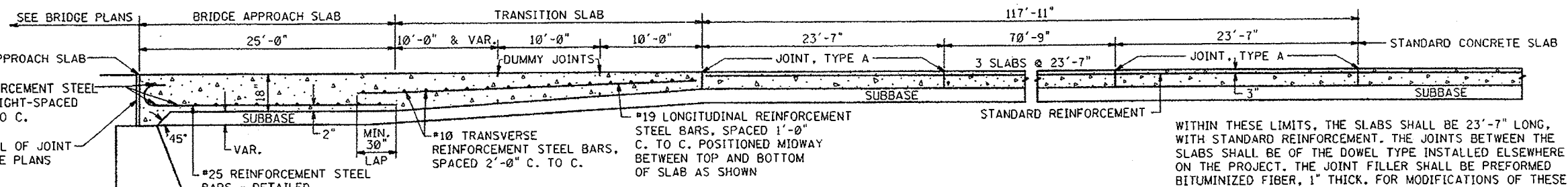
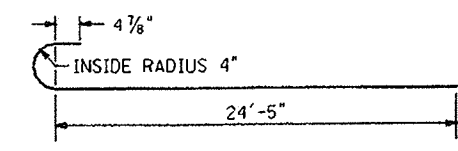
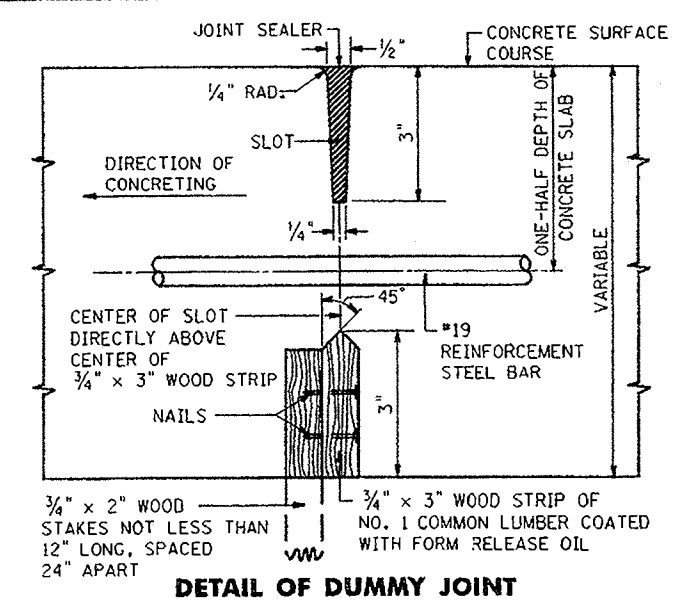

NOTE:
 IF WATER IS POCKETED, INSTALL OUTLET TRENCH AT LOW POINT.
TYPICAL SECTION FOR SUBBASE UNDER APPROACH AND TRANSITION SLABS

NOTES:
 REINFORCING BARS ARE IN METRIC UNITS.
 HMA = HOT ASPHALT MIX

BRIDGE APPROACH SLABS AND TRANSITION SLABS ADJOINING CONCRETE PAVEMENT

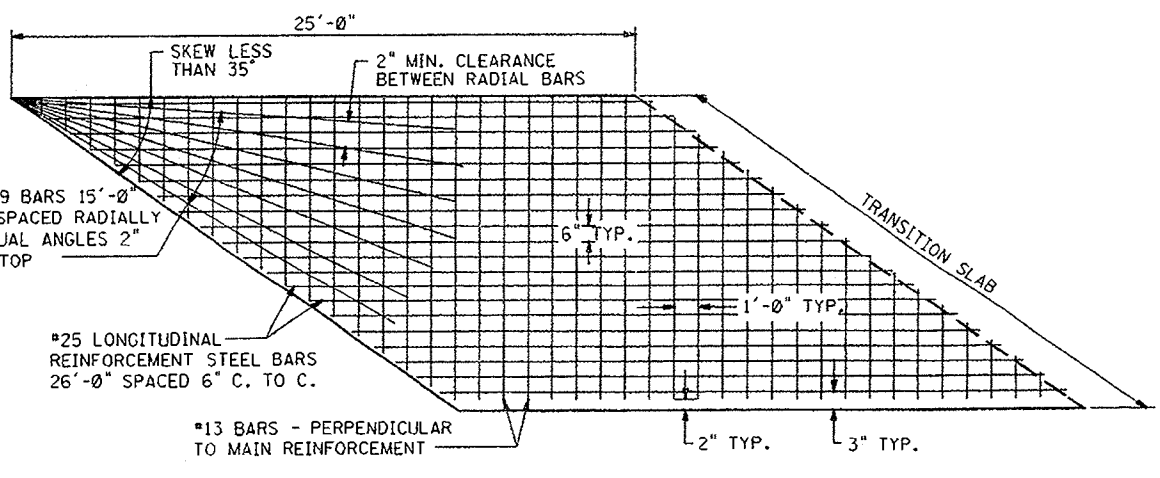
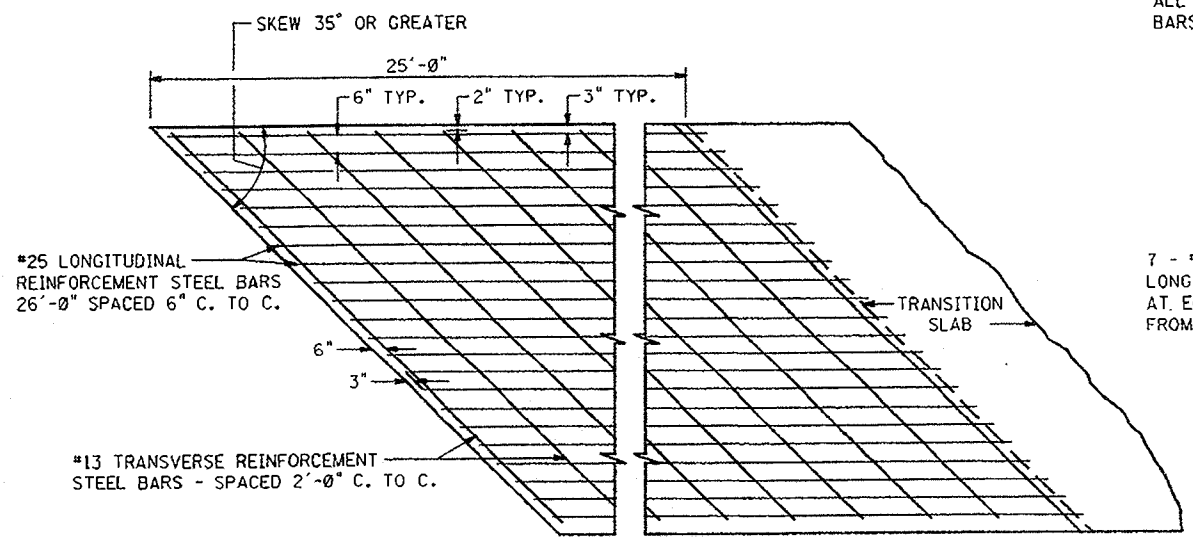

DETAIL FOR BRIDGE APPROACH SLABS WHEN SKEW ANGLE IS 35° OR GREATER

DETAIL FOR BRIDGE APPROACH SLABS WHEN SKEW ANGLE IS LESS THAN 35°

NEW JERSEY DEPARTMENT OF TRANSPORTATION

CONSTRUCTION DETAILS

CD-405-7

NOTES:

EITHER UNDERDRAIN TYPE F WITH PERFORATED PIPE OR UNDERDRAIN TYPE F WITH POROUS PIPE MAY BE USED AT THE OPTION OF THE CONTRACTOR.

UNDERDRAIN IS SHOWN PARALLEL TO THE EDGE OF PAVEMENT, BUT MAY BE USED IN OTHER LOCATIONS IF SO DIRECTED BY THE ENGINEER.

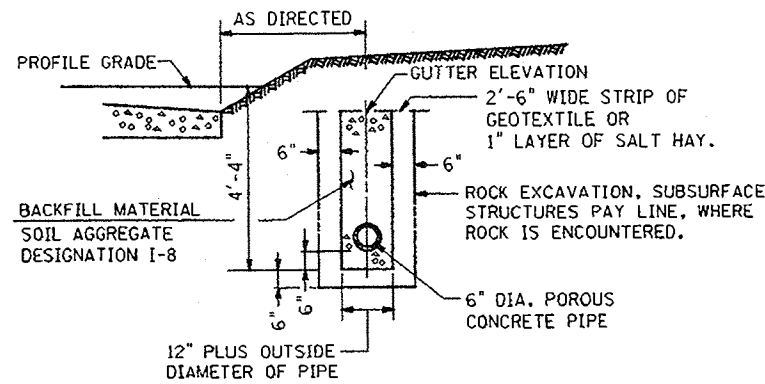

UNDERDRAIN TYPE F WITH POROUS PIPE

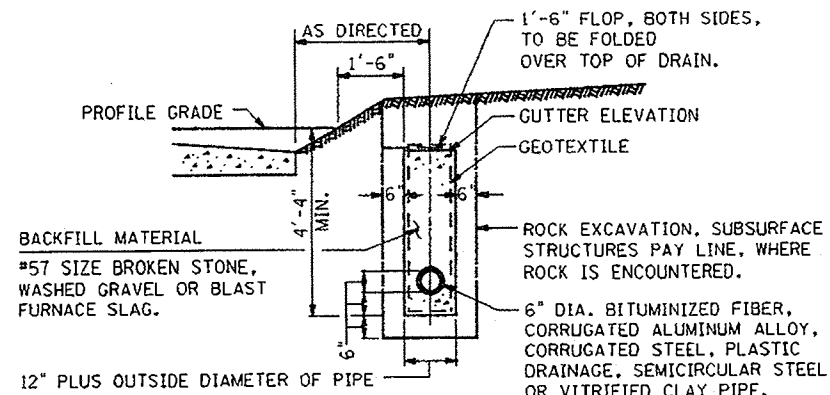

UNDERDRAIN TYPE F WITH PERFORATED PIPE

CD-601-1.1

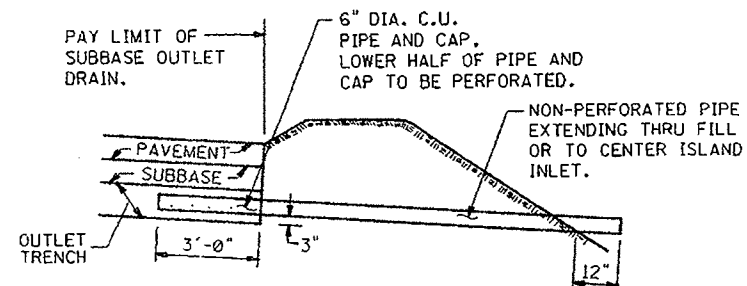
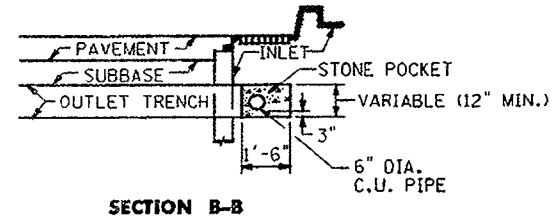
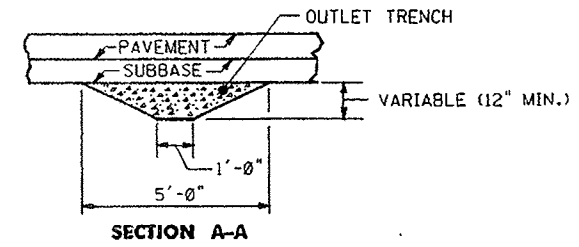

SCHEME FOR WATER DISPOSAL WHERE INLETS ARE IN CENTER ISLAND OR ARE NOT AVAILABLE

SUBBASE OUTLET DRAIN WITH 6" CORRUGATED UNDERDRAIN PIPE

CD-601-1.2

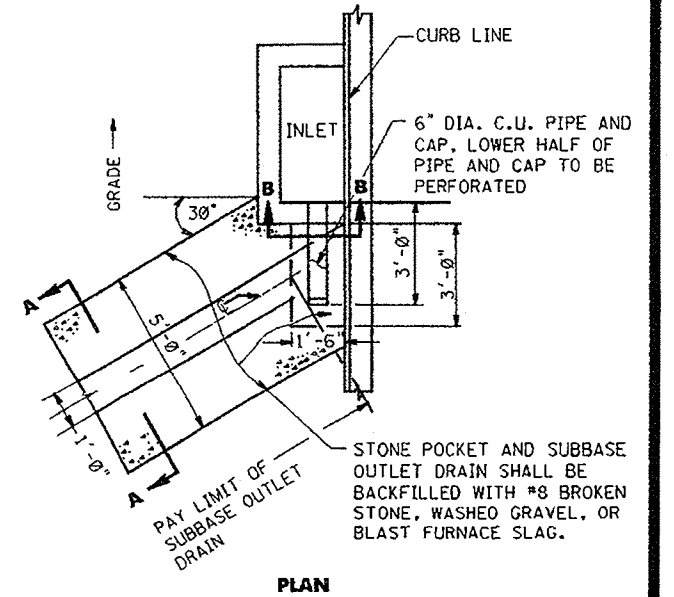

NOTE:
DISCHARGED WATER SHALL IN NO CASE VIOLATE DRAINAGE RIGHTS.

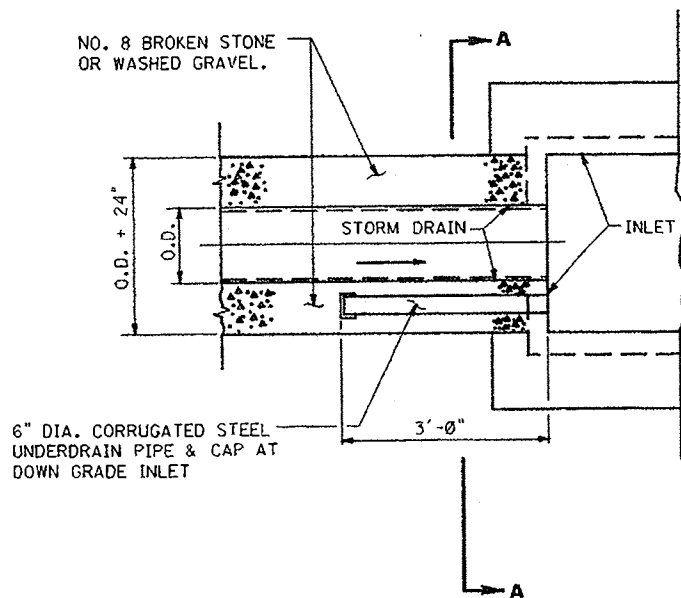

COMBINED STORM DRAIN AND OUTLET TRENCH IN ROCK CUTS

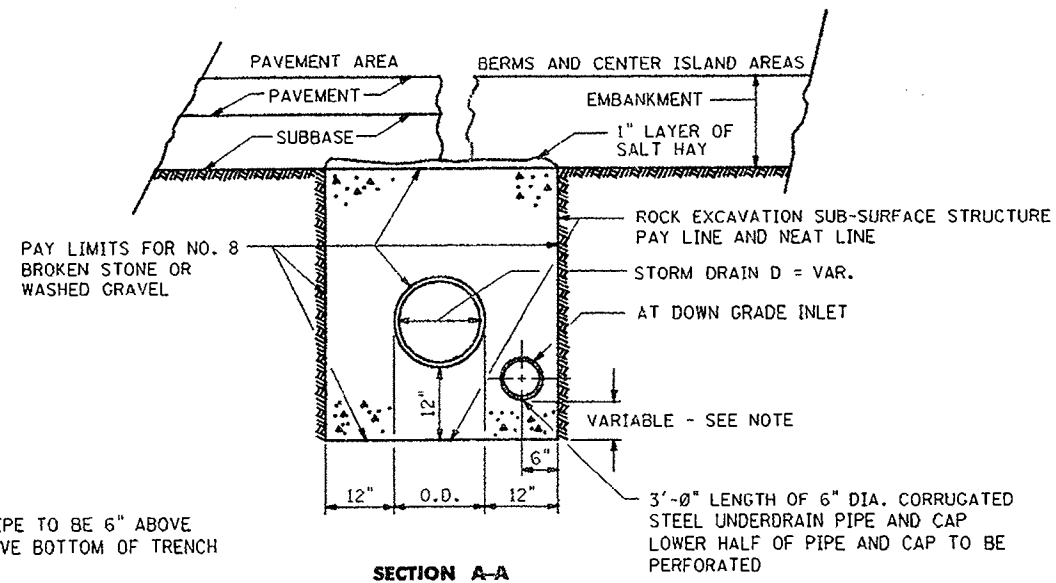

NOTE:
INVERT OF 6" DIA. STEEL PIPE TO BE 6" ABOVE BOTTOM OF INLET OR 6" ABOVE BOTTOM OF TRENCH WHICHEVER IS HIGHER.

UNDERDRAINS

N.T.S.

CD-601-1

NEW JERSEY DEPARTMENT OF TRANSPORTATION

CONSTRUCTION DETAILS

CD-601-1.3

PIPE DIAMETER (INCHES)	STEEL GA.	ALUM. GA.	DIMENSIONS (INCHES)	
			L	C
12	16	16	21	36
15	16	16	26	44
18	16	16	31	52
21	16	16	36	60
24	16	16	41	68
30	14	14	51	84
36	14	12	60	100
42	12	12	69	116
48	12	12	78	126
54	12	12	84	138
60	12	12	87	150
66	12	12	87	156
72	12	12	87	162
78	12	12	87	168
84	12	12	87	174

ROUND PIPE

ARCH PIPE DIMENSION (INCHES)	SPAN	RISE	STEEL GA.	ALUM. GA.	DIMENSIONS (INCHES)	
					L	C
17	13	16	16	16	19	44
21	15	16	16	16	23	50
24	18	16	16	16	28	58
28	20	16	16	16	32	66
35	24	14	14	14	39	80
42	29	14	14	14	46	99
49	33	12	12	12	53	111
57	38	12	12	12	63	126
64	43	12	12	12	70	138
71	47	12	12	12	77	150
77	52	12	12	12	77	162
83	57	12	12	12	77	174

ARCH PIPE

NOTES:

- MINOR VARIATIONS TO THE ABOVE DIMENSIONS ARE ACCEPTABLE WITH THE EXCEPTION OF THE INSIDE DIAMETER DIMENSION.
- A 1 INCH THICK MORTAR BED AND A 6 INCH DEEP LAYER OF COURSE AGGREGATE ARE REQUIRED WHEN A PRECAST CONCRETE CUTOFF WALL IS USED.
- NO SEPARATE PAYMENT WILL BE MADE FOR THE CONCRETE CUTOFF WALL. THE COST OF THE CONCRETE CUTOFF WALL SHALL BE INCLUDED IN THE COST OF THE END SECTION.
- REFER TO NOTE 4, CD-602-1.2 FOR SIZE OF CONCRETE CUTOFF WALL.

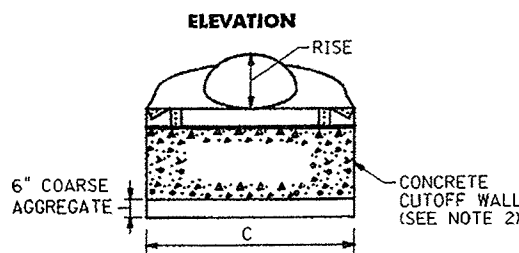
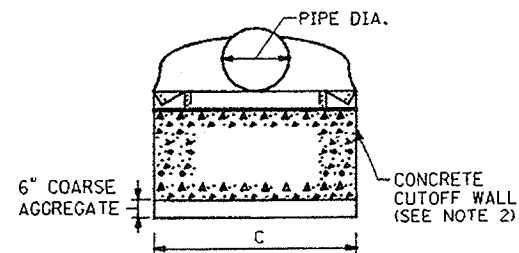
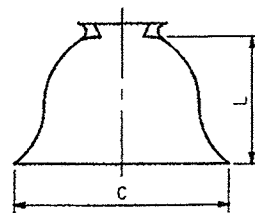
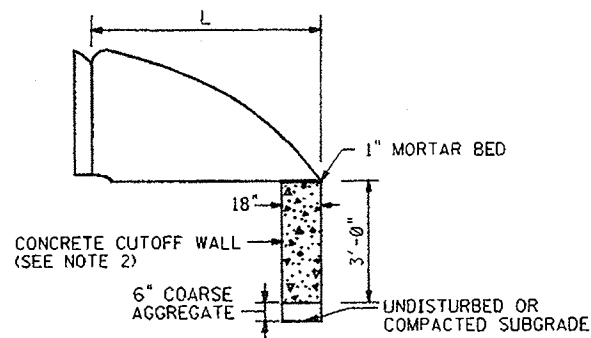

END SECTIONS FOR METAL PIPE

CD-602-1.1

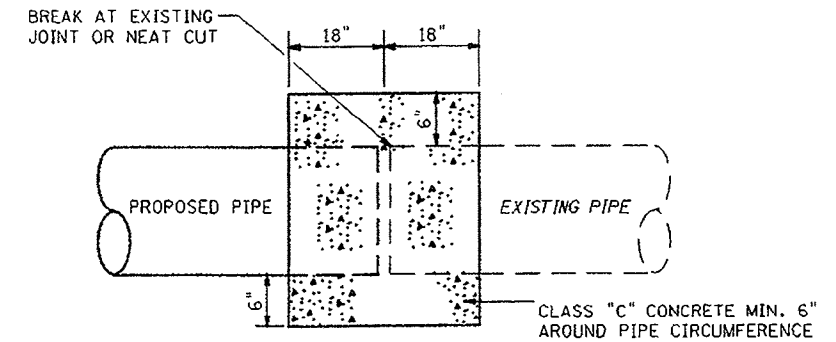

NOTE:

COAT ALL SURFACES TO BE ENCASED IN CONCRETE COLLAR WITH APPROVED EPOXY BONDING COMPOUND. NO SEPARATE PAYMENT WILL BE MADE FOR THE CONCRETE COLLAR. THE COST OF THE CONCRETE COLLAR SHALL BE INCLUDED IN THE COST OF THE VARIOUS PIPE ITEMS ON THE PROJECT.

CONCRETE COLLAR

(FOR JOINING PROPOSED PIPE TO EXISTING PIPE)

CD-602-1.3

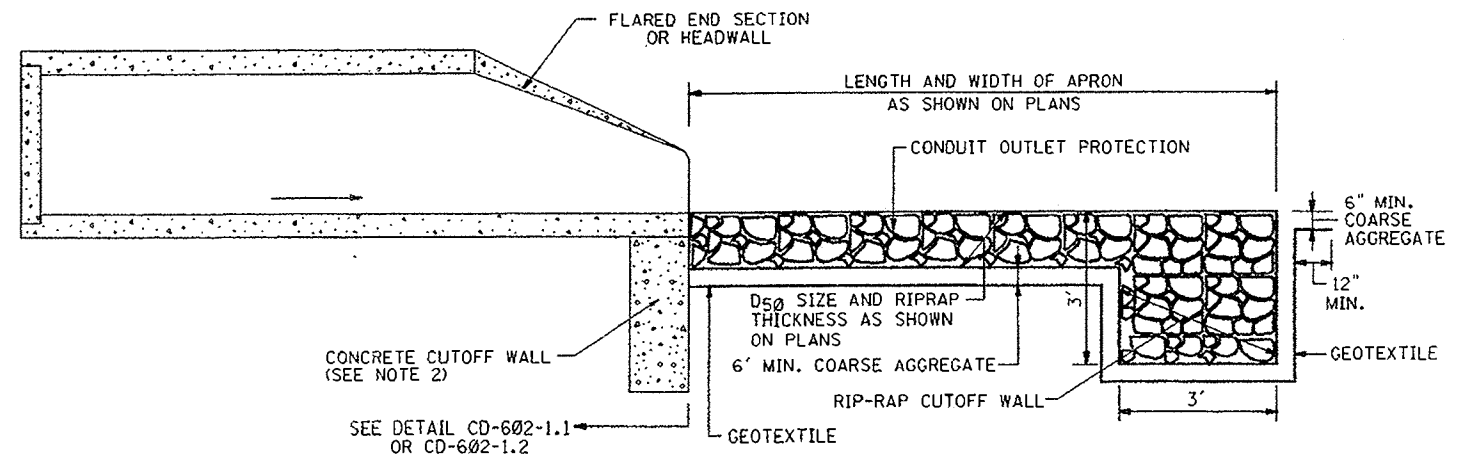

STORMWATER OUTFALL PROTECTION

CD-602-1.4

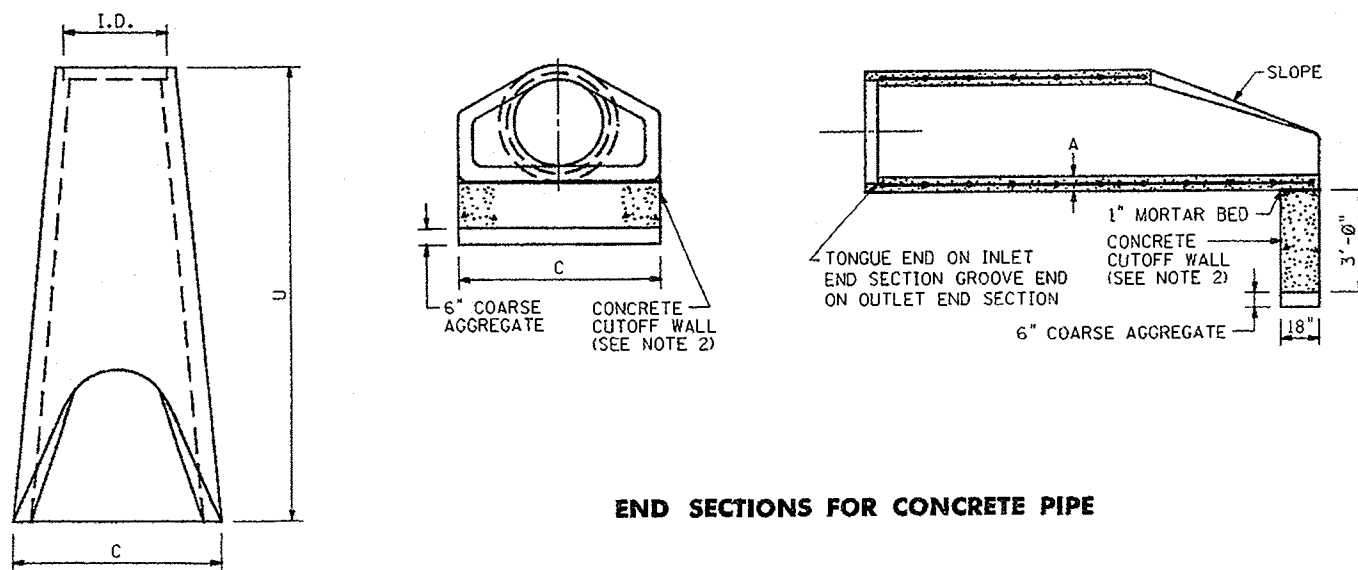

END SECTIONS FOR CONCRETE PIPE

I.D.	DIMENSIONS (INCHES)											
	12	15	18	21	24	27	30	36	42	48	54	60
A	2	2 1/4	2 1/2	2 3/4	3	3 1/4	3 1/2	4	4 1/2	5	5 1/2	6
U	72	72	72	72	72	72	72	96	96	96	96	96
C	28	34.5	41	47.5	54	60.5	67	80	87	94	101	108

NOTES:

- MINOR VARIATIONS TO THE ABOVE DIMENSIONS ARE ACCEPTABLE WITH THE EXCEPTION OF THE INSIDE DIAMETER DIMENSION.
- A 1 INCH THICK MORTAR BED AND A 6 INCH DEEP LAYER OF COURSE AGGREGATE ARE REQUIRED WHEN A PRECAST CONCRETE CUTOFF WALL IS USED.
- NO SEPARATE PAYMENT WILL BE MADE FOR THE CONCRETE CUTOFF WALL. THE COST OF THE CONCRETE CUTOFF WALL SHALL BE INCLUDED IN THE COST OF THE END SECTION.
- THE WIDTH OF THE CONCRETE CUTOFF WALL SHALL BE EQUAL TO THE MAXIMUM WIDTH OF THE END SECTION AS INDICATED ON THE DETAIL BY DIMENSION "C". HOWEVER, IF THE ACTUAL MAXIMUM WIDTH EXCEEDS THE CHART VALUE OF "C", THE WIDTH OF THE CONCRETE CUTOFF WALL SHALL EQUAL THE ACTUAL MAXIMUM WIDTH OF THE END SECTION.

CD-602-1.2

PIPE END SECTIONS

N.T.S.

CD-602-1

NEW JERSEY DEPARTMENT OF TRANSPORTATION

CONSTRUCTION DETAILS

NOTE:
SEE CD-602-2.6 FOR THE DIMENSION OF "d".

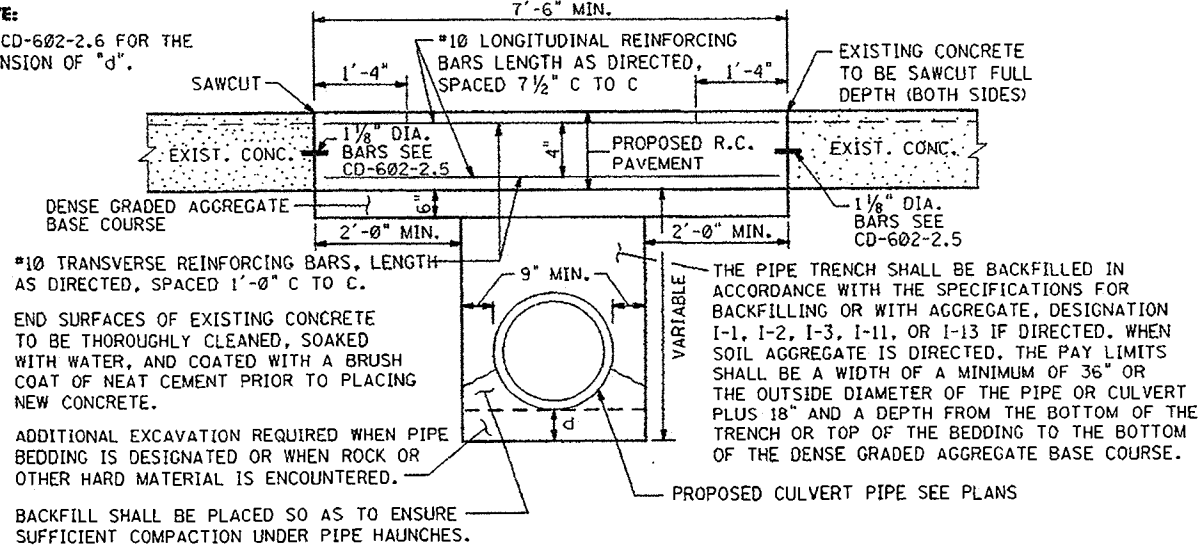

CONCRETE SURFACE COURSE REPLACEMENT AT CROSS DRAIN TRENCH

CD-602-2.1

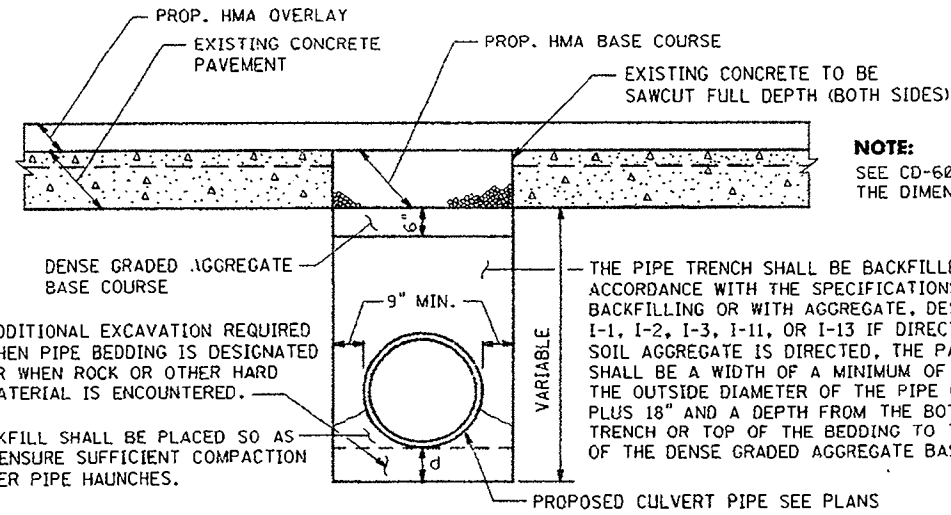

HMA REPLACEMENT WHERE EXISTING CONCRETE COURSE IS REMOVED AT CROSS DRAIN TRENCH WITH PROPOSED RESURFACING

CD-602-2.4

UNDERLYING SOIL	d	
	CONC. PIPE	METAL PIPE
ROCK OR HARD MATERIAL	6"	12"
OTHER MATERIAL	6"	6"

MINIMUM DEPTH OF ADDITIONAL EXCAVATION OR PIPE BEDDING

CD-602-2.6

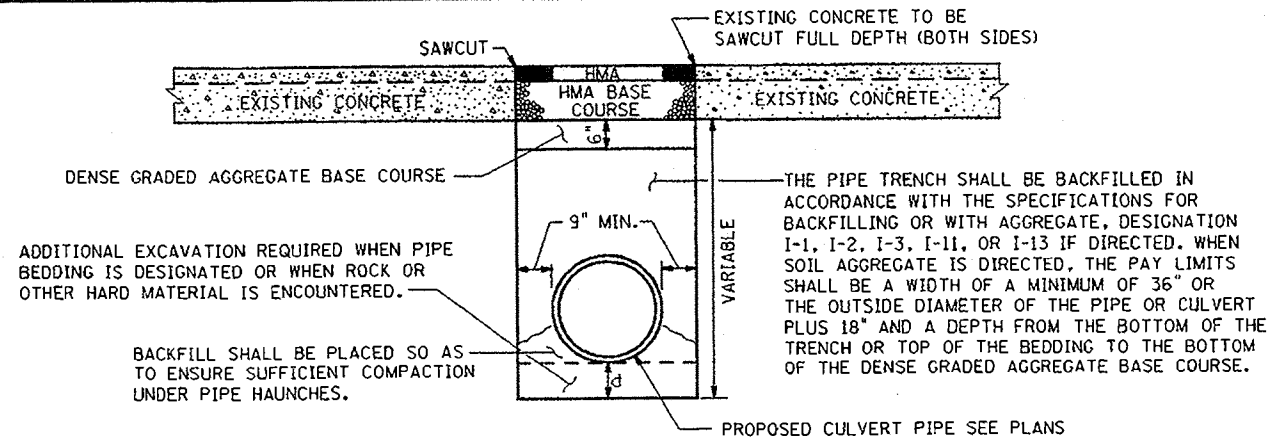

HMA REPLACEMENT WHERE CONCRETE COURSE IS REMOVED AT CROSS DRAIN TRENCH

CD-602-2.2

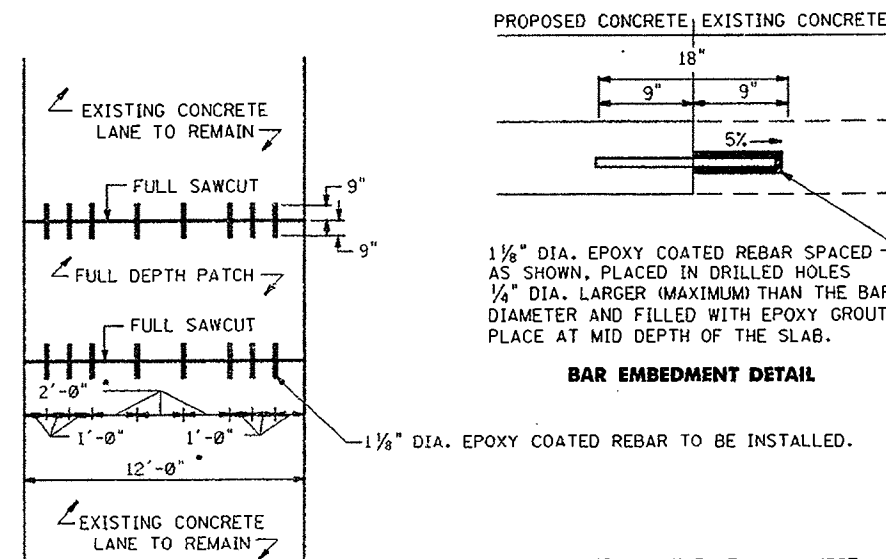

TRANSVERSE JOINT TIE IN CONCRETE SURFACE COURSE FOR CONDUIT OR CROSS DRAIN TRENCHES

CD-602-2.5

NOTES:
REINFORCING BARS ARE IN METRIC UNITS.
HMA = HOT ASPHALT MIX

CROSS DRAIN TRENCH CONSTRUCTION
N.T.S.

CD-602-2

NEW JERSEY DEPARTMENT OF TRANSPORTATION

CONSTRUCTION DETAILS

CD-602-2.3

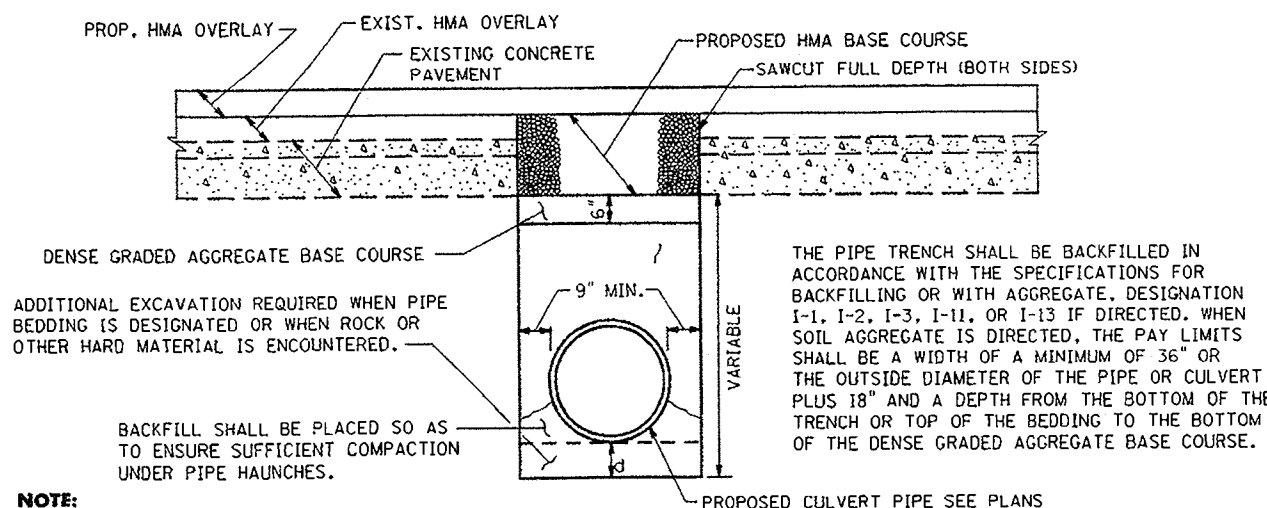

HMA REPLACEMENT WHERE EXISTING OVERLAY AND CONCRETE COURSE IS REMOVED AT CROSS DRAIN TRENCH WITH PROPOSED RESURFACING

NOTE:
SEE CD-602-2.6 FOR THE DIMENSION OF "d".

ORIGINAL SHEET

GENERAL NOTES

1. INLETS MAY BE CONSTRUCTED OF BRICK, CONCRETE, CONCRETE BLOCK OR PRECAST CONCRETE. WALLS SHALL BE 8 INCHES THICK IF BRICK AND 6 INCHES THICK IF CONCRETE, CONCRETE BLOCK OR PRECAST CONCRETE. INLET FOUNDATIONS AND INVERTS SHALL BE CLASS C CONCRETE.
2. CORBELLING OF INLET WALLS WILL BE PERMITTED AT THE RATE OF 1/2" PER 8 INCHES OF HEIGHT; MAXIMUM CORBEL 6 INCHES PER WALL.
3. EXCEPT FOR INLETS TYPE A AND C, FOUNDATIONS AND INVERTS SHALL BE CONSTRUCTED IN TWO STAGES, AND THE BOTTOM OF THE FOOTINGS SHALL BE 8 INCHES BELOW THE OUTER WALL OF THE LOWEST PIPE IN THE INLET.
4. WHEN THE DEPTH OF AN INLET THAT IS NOT PRECAST EXCEEDS 10 FEET AS MEASURED FROM TOP OF GRATE TO INVERT, WALLS BELOW A DEPTH OF 8 FEET SHALL BE 12 INCHES THICK AND THE DEPTH OF FOUNDATION INCREASED TO 12 INCHES. WHEN ROCK IS ENCOUNTERED, THE DEPTH OF THE FOUNDATION SHALL NOT BE INCREASED.
5. INLET FOUNDATIONS WHICH ARE PRECAST SHALL BE PLACED ON A 6 INCH THICK BED OF COMPACTED COARSE AGGREGATE SIZE NO. 57. THE COARSE AGGREGATE SHALL EXTEND 6 INCHES BEYOND THE HORIZONTAL LIMITS OF THE INLET FOUNDATION.
6. CASTINGS FOR PRECAST INLETS SHALL BE ADJUSTED TO GRADE WITH COURSES OF BRICK, AS REQUIRED, 12 INCHES MAXIMUM.
7. WHEN THE DEPTH OF A PRECAST INLET EXCEEDS 10 FEET AS MEASURED FROM TOP OF GRATE TO INVERT, THE FOUNDATION SHALL BE INCREASED TO 12 INCHES. WHEN ROCK IS ENCOUNTERED, THE DEPTH OF THE FOUNDATION SHALL NOT BE INCREASED.
8. MINIMUM WALL REINFORCEMENT FOR PRECAST INLETS TYPES A, B, C, E, D-1, D-2 AND B MODIFIED:

DEPTH BELOW TOP OF GRATE	HORIZONTAL REINF.	VERTICAL REINF.	WALL THK.
0' TO 10'-0"	#13 @ 10" C.C.	#13 @ 18" C.C.	6"
10'-1" TO 15'-0"	#13 @ 8" C.C.	#13 @ 18" C.C.	6"
15'-1" TO 20'-0"	#13 @ 6" C.C.	#13 @ 18" C.C.	6"

REINFORCING SHOWN FOR PRECAST INLETS IS THE MINIMUM REQUIRED. ADDITIONAL REINFORCING FOR HANDLING IS THE RESPONSIBILITY OF THE CONTRACTOR.

ALTERNATE REINFORCEMENT

DEPTH BELOW TOP OF GRATE	REINFORCEMENT
0' TO 10'-0"	WWF 3 x 6 W6 WIRES SPACED AT 3" TO RUN HORIZONTAL IN ALL CASES.
10'-1" TO 15'-0"	WWF 3 x 6 W6 ADD #10 BAR @ 18" HORIZONTAL.
15'-1" TO 20'-0"	WWF 3 x 6 W6 ADD #10 BAR @ 9" HORIZONTAL OR ADD #13 BAR AT 15" HORIZONTAL.

9. ALL INLETS AND MANHOLES SHALL BE CONSTRUCTED IN ACCORDANCE WITH THE CURRENT NJDOT STANDARD SPECIFICATIONS FOR ROAD AND BRIDGE CONSTRUCTION AND ITS AMENDMENTS.

NOTES:
REINFORCING BARS ARE IN METRIC UNITS.

INLET GENERAL DETAILS

N.T.S.

CD-603-1

NEW JERSEY DEPARTMENT OF TRANSPORTATION

CONSTRUCTION DETAILS

CONNECTION OF PIPE AND INLET FOR PRECAST INLET

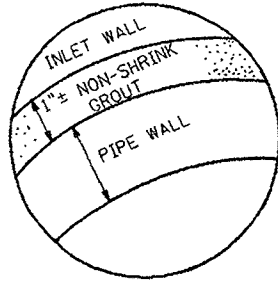

CD-603-1.1

RISER JOINT DETAIL FOR PRECAST INLETS

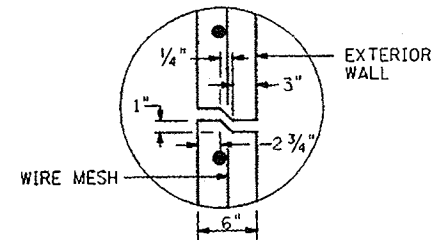

NOTE:
JOINT TO BE SECURELY MORTARED BY CONTRACTOR

CD-603-1.2

LADDER RUNG DETAIL

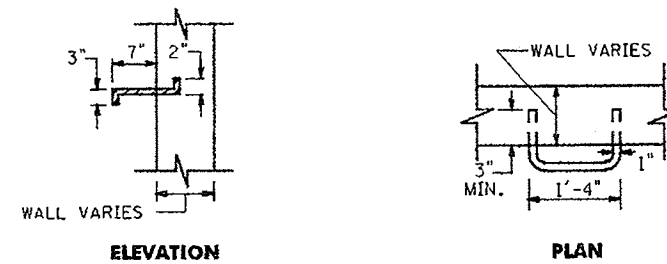

NOTE:
LADDER RUNGS FACING TRAFFIC 12" C TO C

CD-603-1.3

DETAIL OF INVERT FOR INLET WITHOUT CONTINUOUS PIPE

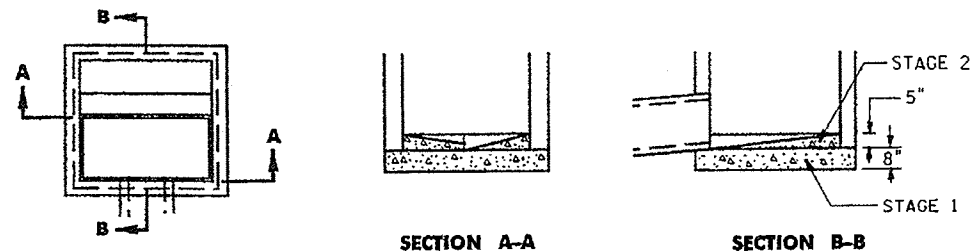

NOTE:
FOUNDATION AND INVERT TO BE CONSTRUCTED IN TWO STAGES. THE TOP SURFACE OF STAGE 1 TO BE LEFT ROUGH.

CD-603-1.4

COPOLYMER POLYPROPYLENE PLASTIC LADDER RUNG

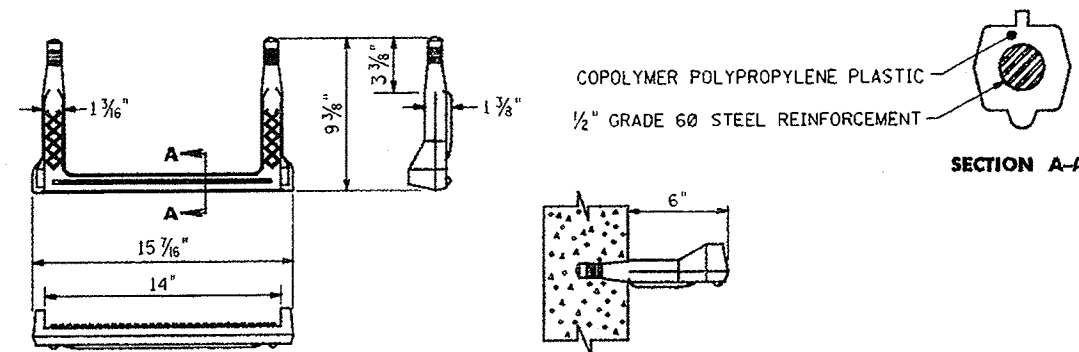

CD-603-1.5

NEW MANHOLE CASTINGS, SQUARE FRAME, CIRCULAR COVER

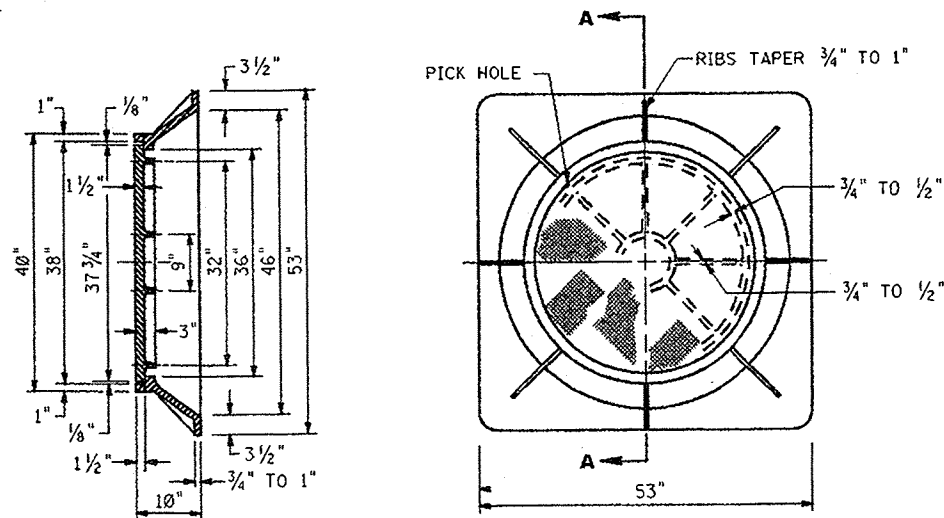

NOTE:
MINIMUM WEIGHTS
WEIGHT OF FRAME 630#
WEIGHT OF COVER 400#

CD-603-1.7

MIN. WEIGHT 325 LBS.

BICYCLE SAFE GRATES (CAST IRON)

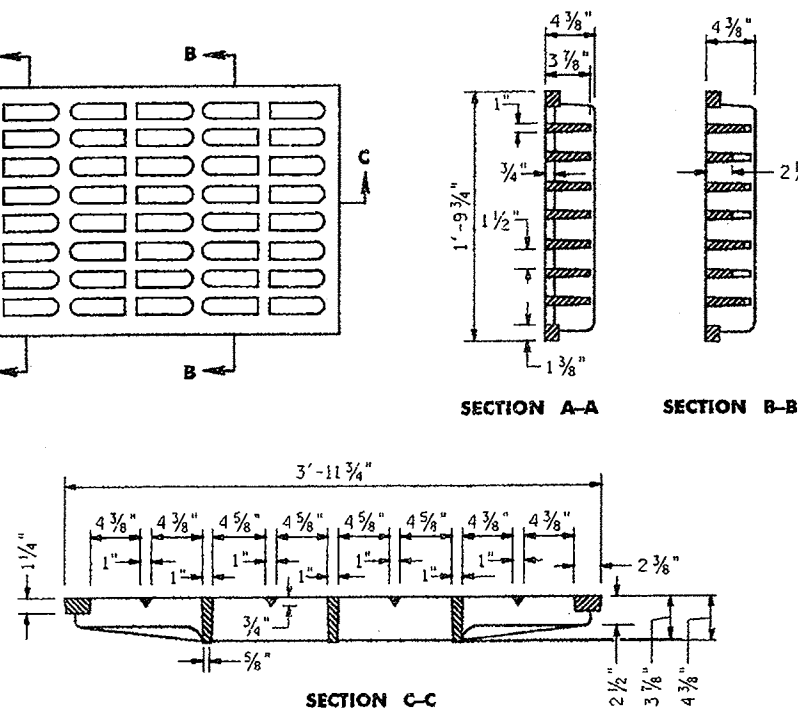

CD-603-1.8

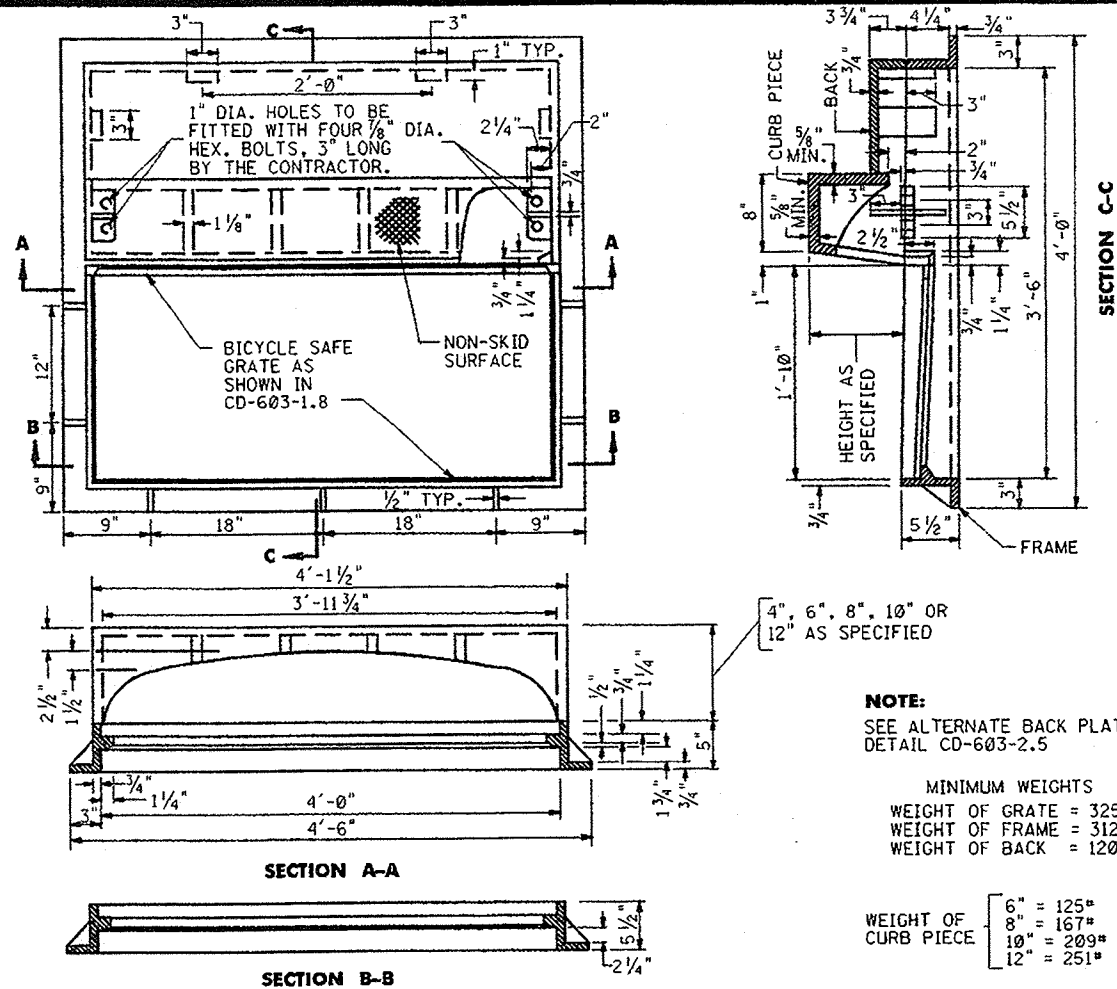

FRAME-BACK-CURB PIECE FOR INLET TYPE B AND TYPE C CD-603-2.1

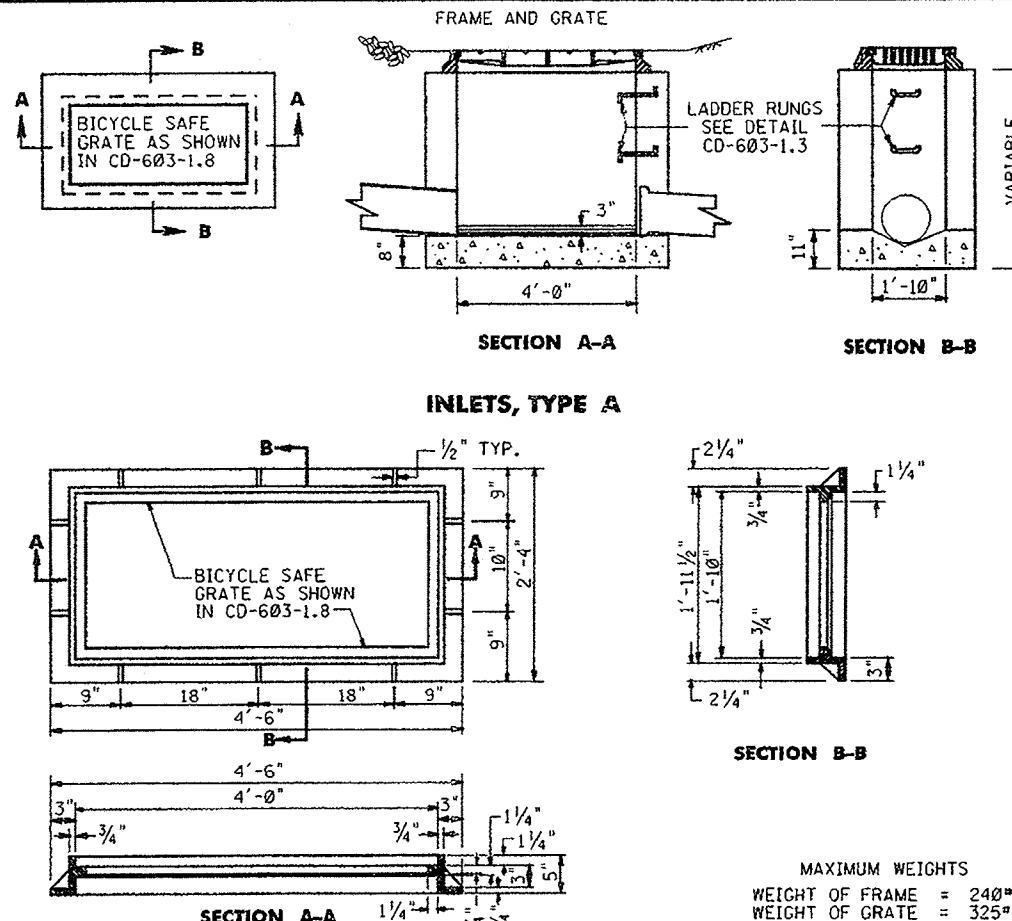

FRAME FOR INLETS, TYPE A CD-603-2.4

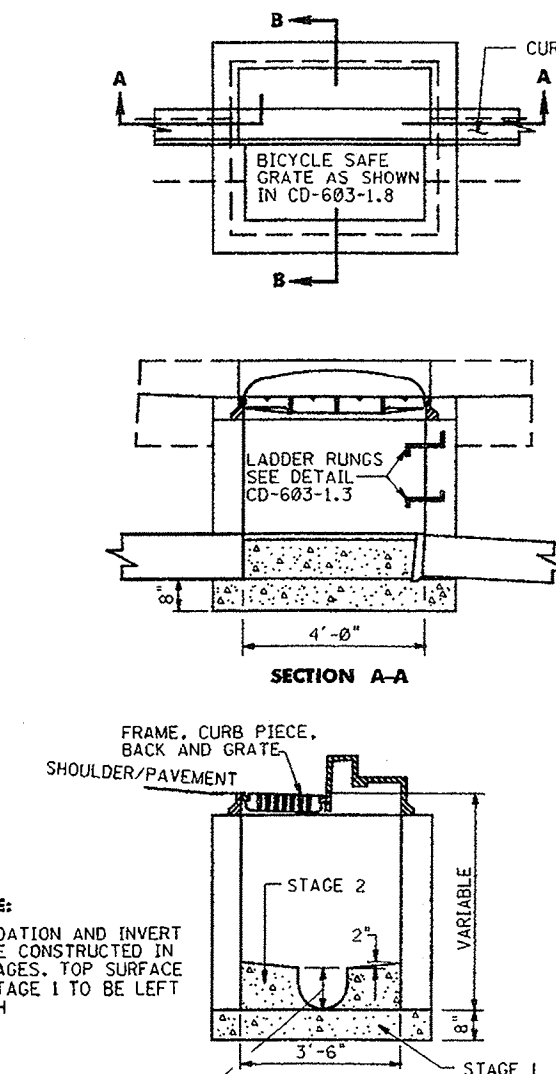

**INLETS, TYPE B WITH C.I. CURB
PIECE-BACK-FRAME AND GRATE**

CD-603-2.6

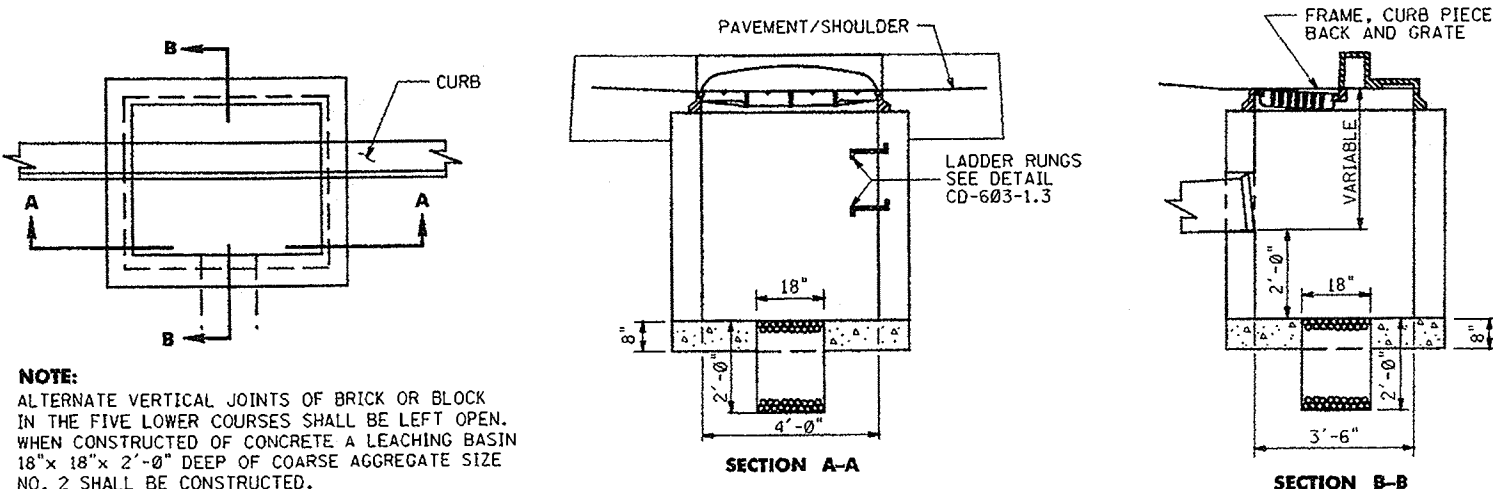

INLETS, TYPE C WITH C.I. CURB PIECE-BACK-FRAME AND GRATE

CD-603-2.2

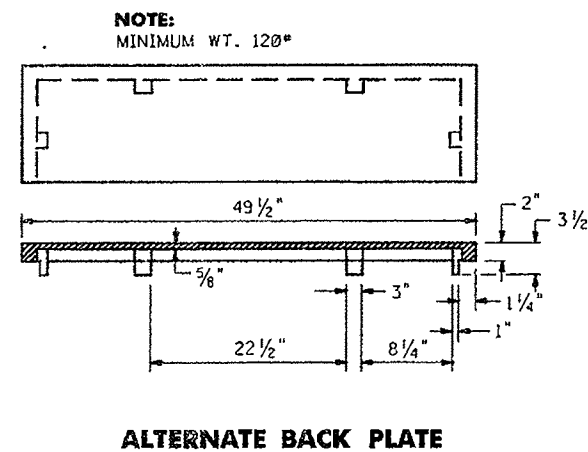

ALTERNATE BACK PLATE

CD-603-2.5

INLETS, TYPE A, B & C
N.T.S.

CD-603-2

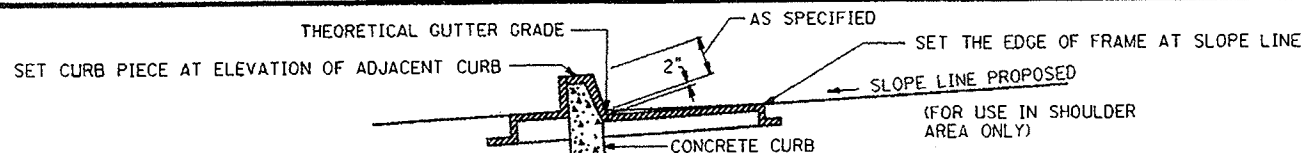

**METHOD OF SETTING CASTING FOR B TYPE INLETS
WHERE CURB PIECE HEIGHT IS 2" GREATER THAN CURB FACE**

CD-603-2.3

CONSTRUCTION DETAILS

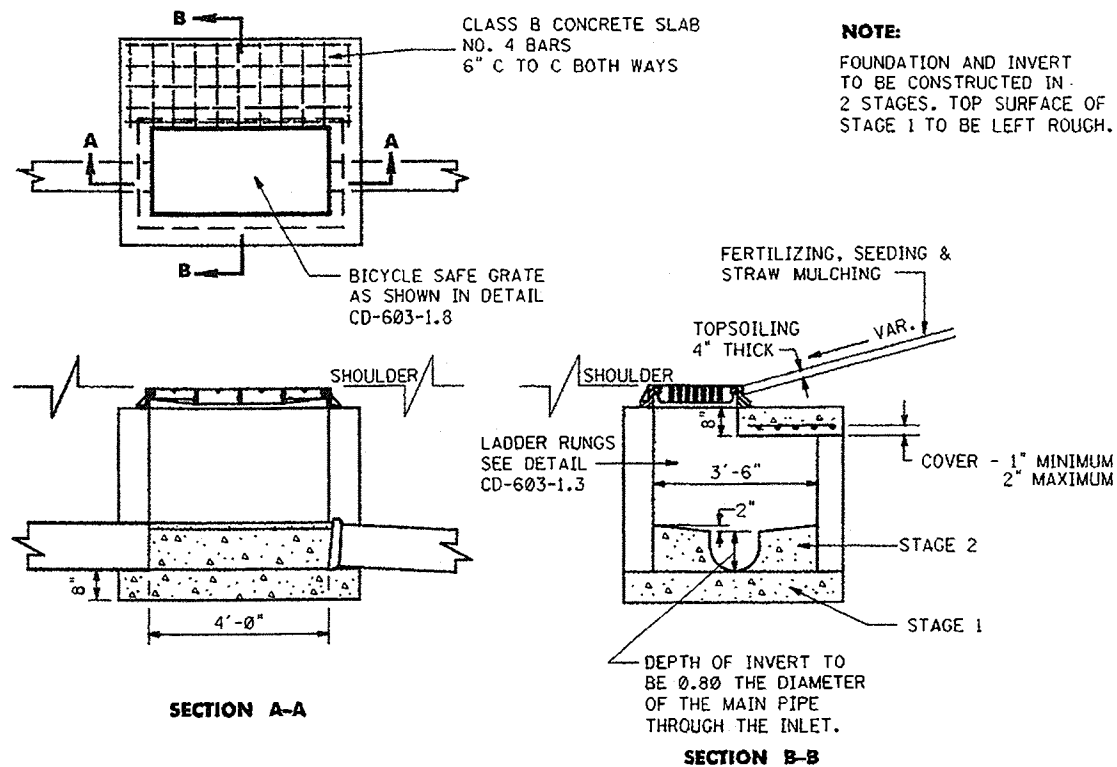

INLETS, TYPE B MODIFIED

CD-603-3.1

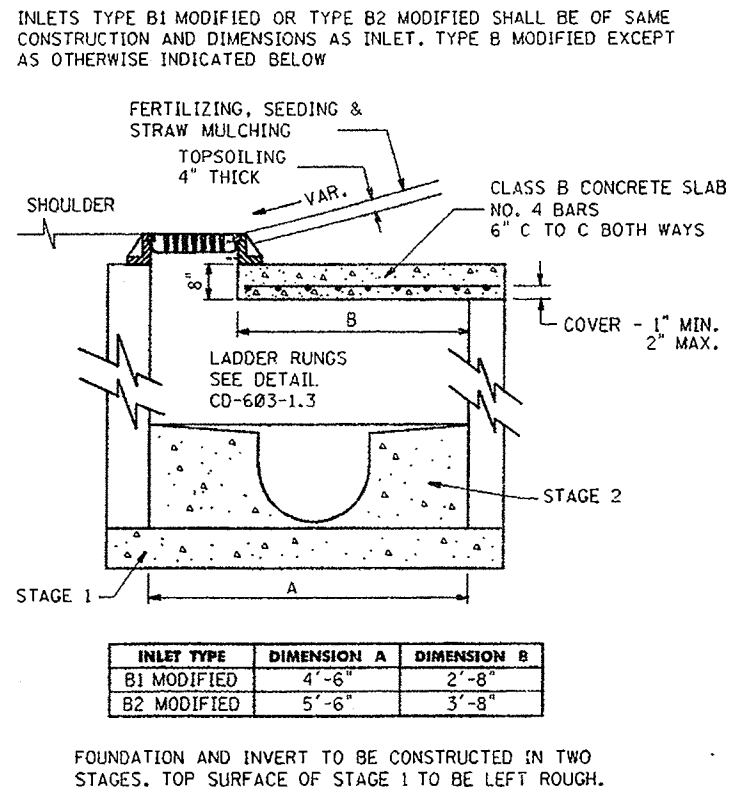

INLETS, TYPE B1 MODIFIED AND TYPE B2 MODIFIED

CD-603-3.2

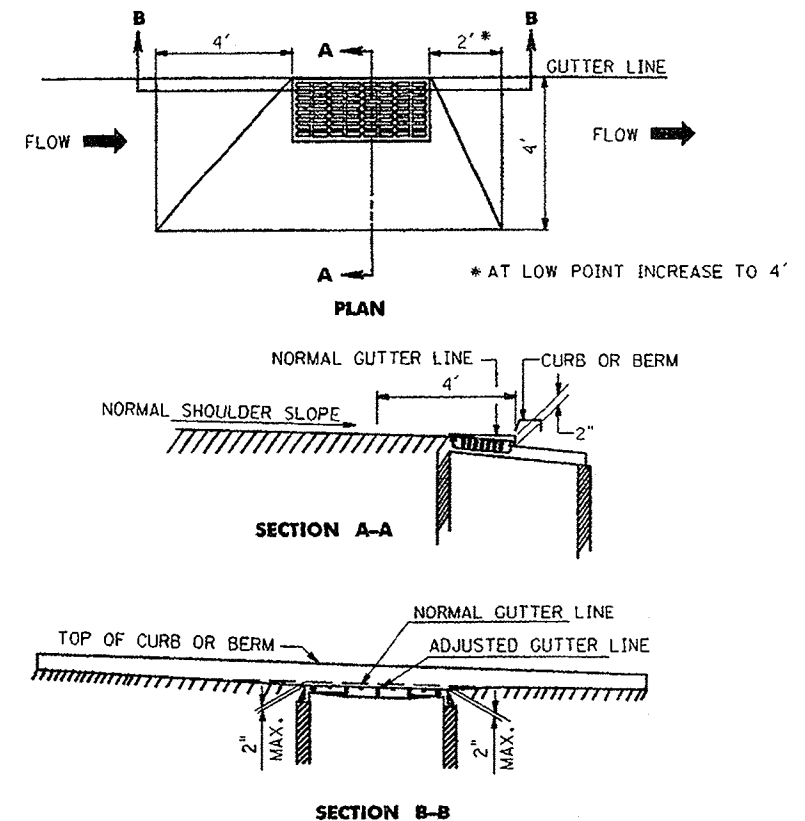

METHOD OF DEPRESSING INLETS AT SHOULDERS

CD-603-3.3

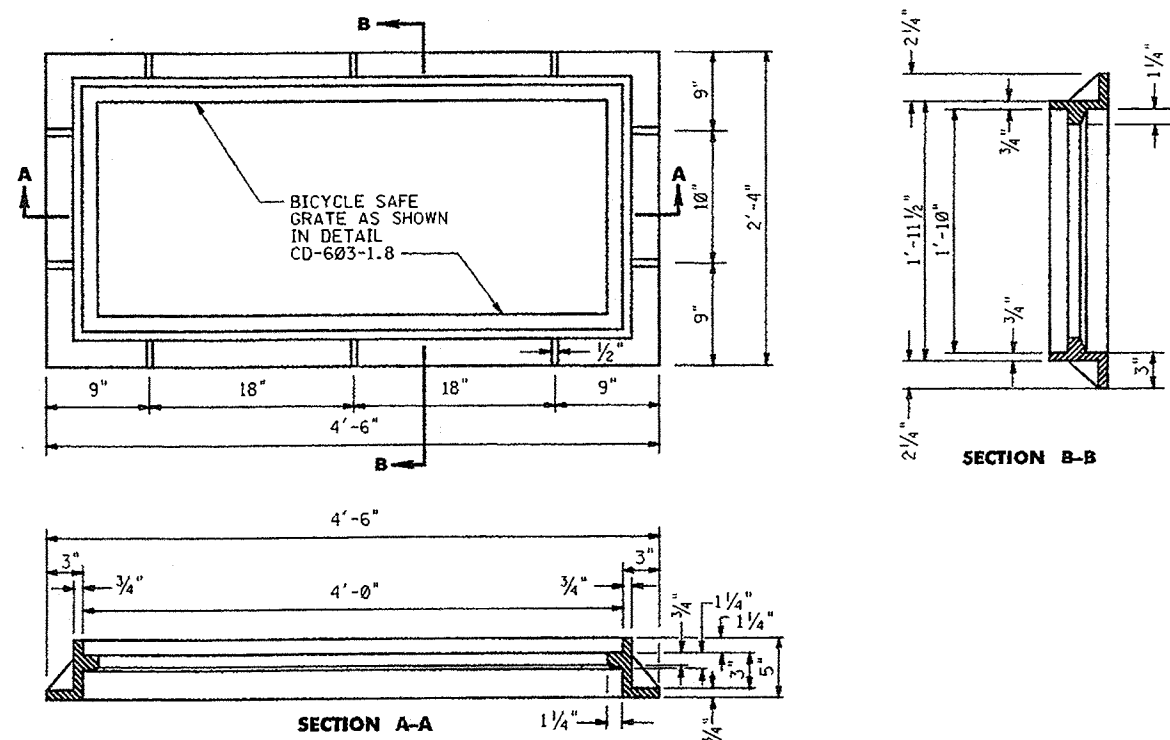

FRAME TO BE USED FOR INLETS, TYPE B MODIFIED

CD-603-3.4

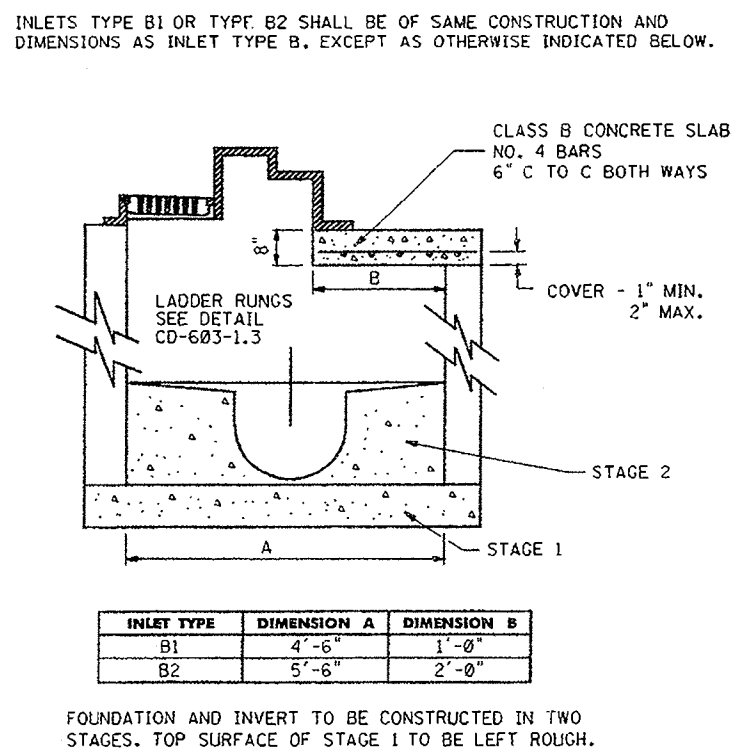

INLETS, TYPE B1 AND TYPE B2

CD-603-3.5

INLETS, TYPE B1, B2, & B, B1, & B2 MODIFIED
N.T.S.

CD-603-3

NEW JERSEY DEPARTMENT OF TRANSPORTATION

CONSTRUCTION DETAILS

INLETS TYPE E1 AND TYPE E2 SHALL BE OF THE SAME CONSTRUCTION AND DIMENSIONS AS INLET TYPE E EXCEPT AS OTHERWISE INDICATED BELOW.

NOTE:

FOUNDATION AND INVERT TO BE CONSTRUCTED IN TWO STAGES. TOP SURFACE OF STAGE 1 TO BE LEFT ROUGH.

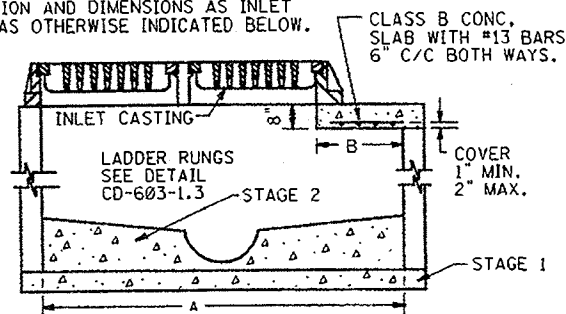

INLET TYPE	DIMENSION A	DIMENSION B
E 1	4'-6"	1'-0"
E 2	5'-6"	2'-0"

INLETS, TYPE E1 AND TYPE E2

CD-603-4.1

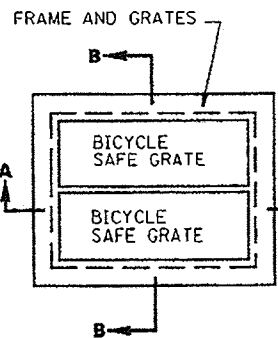

SECTION A-A

INLETS, TYPE E

FRAME AND TWO GRATES

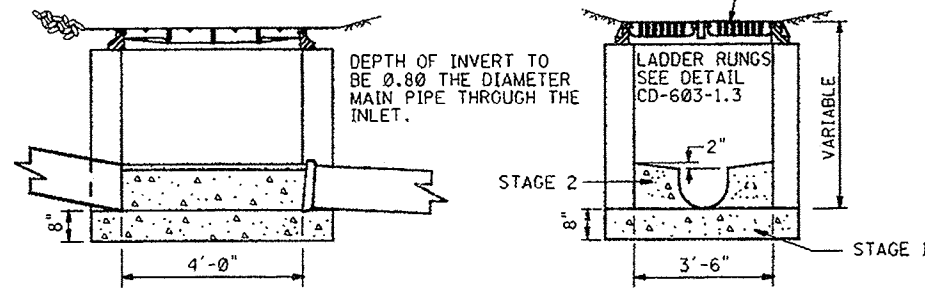

SECTION B-B

NOTE:

FOUNDATION AND INVERT TO BE CONSTRUCTED IN 2 STAGES. TOP SURFACE OF STAGE 1 TO BE LEFT ROUGH.

CD-603-4.2

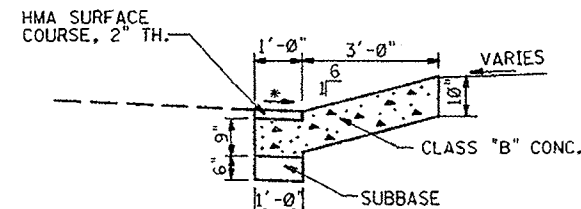

SECTION A-A

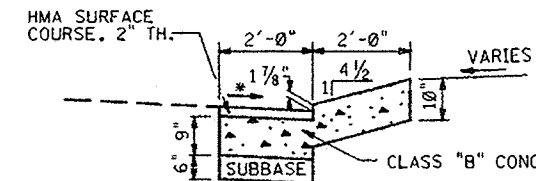

SECTION B-B

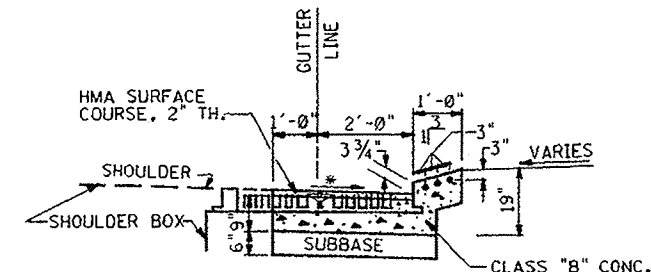

SECTION C-C

• SAME X-SLOPE AS ADJOINING SHOULDER

INLETS, TYPE ES

CD-603-4.4

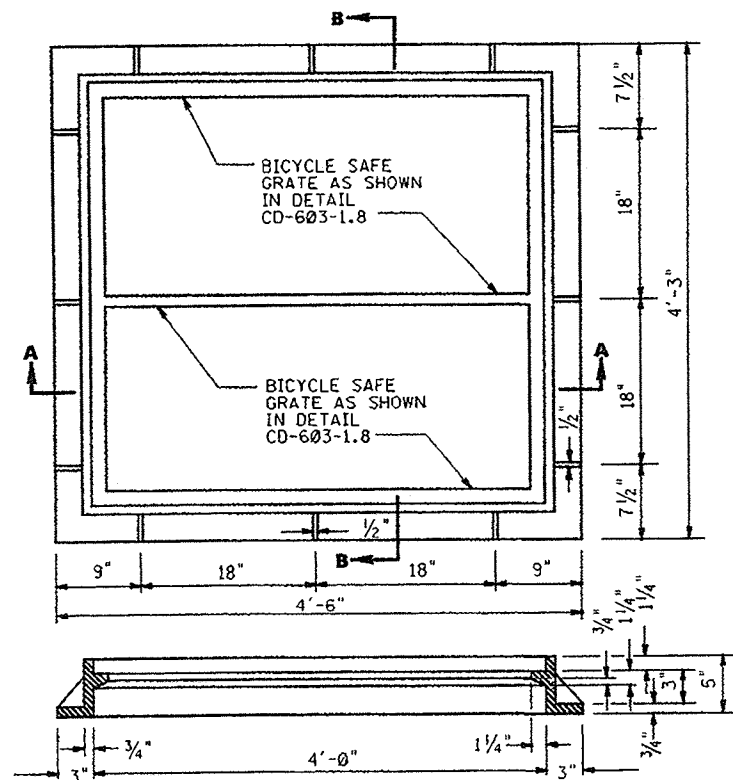

SECTION A-A

FRAME FOR INLETS, TYPE E

SECTION B-B

WEIGHT OF FRAME = 435*
WEIGHT OF EACH GRATE = 325*

CD-603-4.3

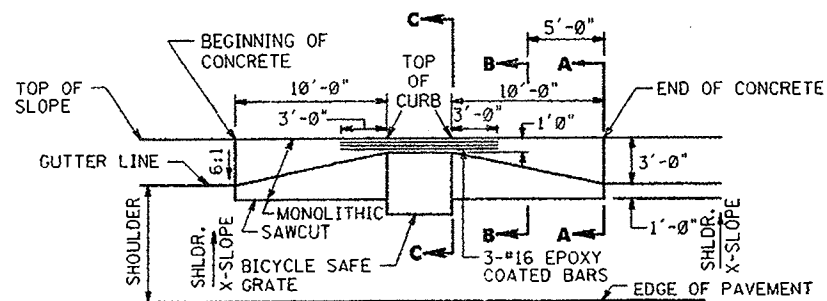

PLAN VIEW

NOTE:

THE UNDERLYING MATERIAL SHALL BE SHAPED AND COMPACTED TO A FIRM, EVEN SURFACE.

NOTE: ITEM INCLUDES

EXCAVATION
SUBBASE DES I-1 OR I-2, 6" TH.
CLASS B CONCRETE (RDWY)
HMA CONCRETE SURFACE COURSE
UNDERLAYER PREPARATION
TACK COAT
INLET, TYPE "E" WITH CASTING.

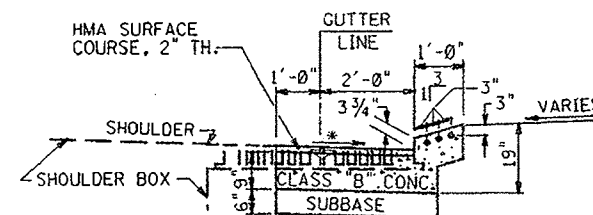

SECTION C-C

NOTE: ITEM INCLUDES

EXCAVATION
SUBBASE DES I-1 OR I-2, 6" TH.
CLASS B CONCRETE (RDWY)
HMA SURFACE COURSE
UNDERLAYER PREPARATION
TACK COAT
INLET CASTING, TYPE "E"
REMOVAL OF EXISTING CLASS B CONCRETE IF REQUIRED.

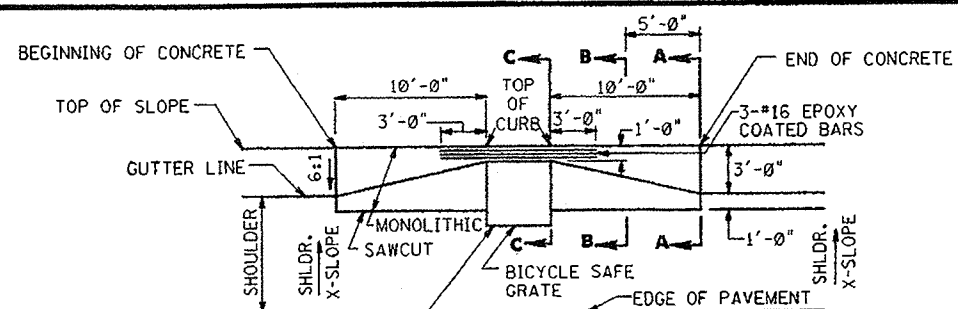

PLAN VIEW

NOTE:

THE UNDERLYING MATERIAL SHALL BE SHAPED AND COMPACTED TO A FIRM, EVEN SURFACE.

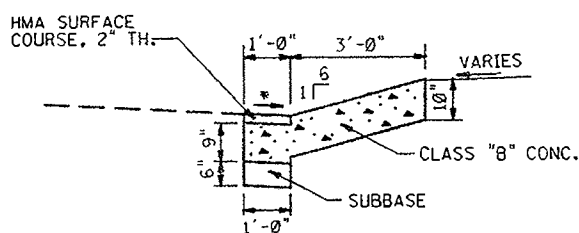

SECTION A-A

INLET CASTINGS, TYPE ES

• SAME X-SLOPE AS ADJOINING SHOULDER

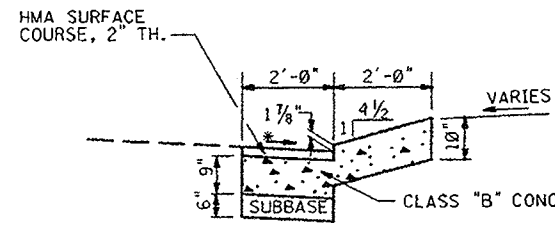

SECTION B-B

CD-603-4.5

NOTES:

REINFORCING BARS ARE IN METRIC UNITS.

INLETS, TYPE E, E1, E2, & ES

N.T.S.

CD-603-4

NEW JERSEY DEPARTMENT OF TRANSPORTATION

CONSTRUCTION DETAILS

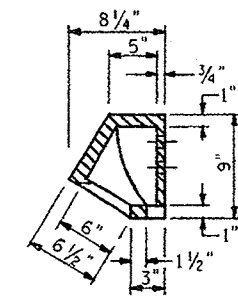
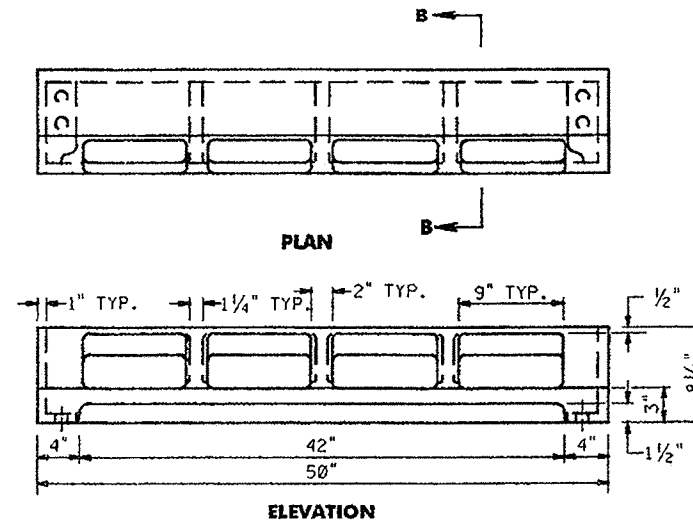
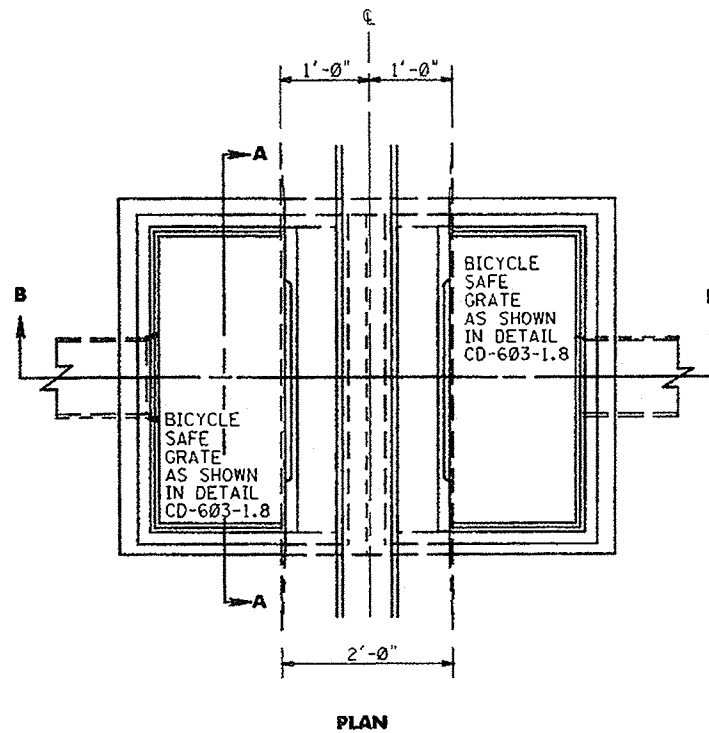
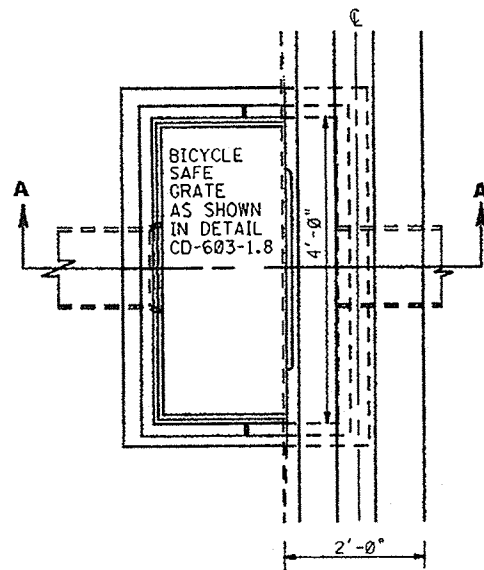

CAST IRON CURB PIECE FOR INLETS, TYPE D1 AND D2

CD-603-5.3

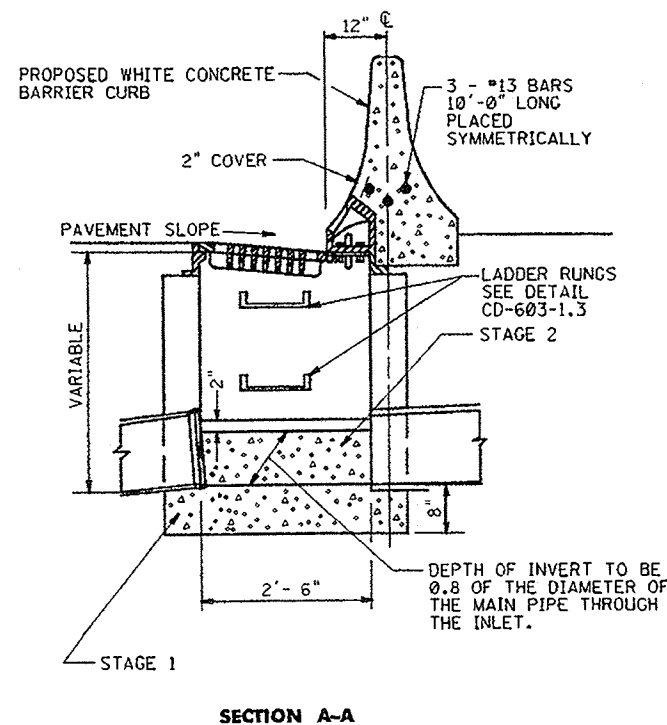

INLETS TYPE D-1

NOTE:
FOUNDATION AND INVERT TO BE CONSTRUCTED IN 2 STAGES
THE TOP SURFACE OF STAGE 1 TO BE LEFT ROUGH.

CD-603-5.1

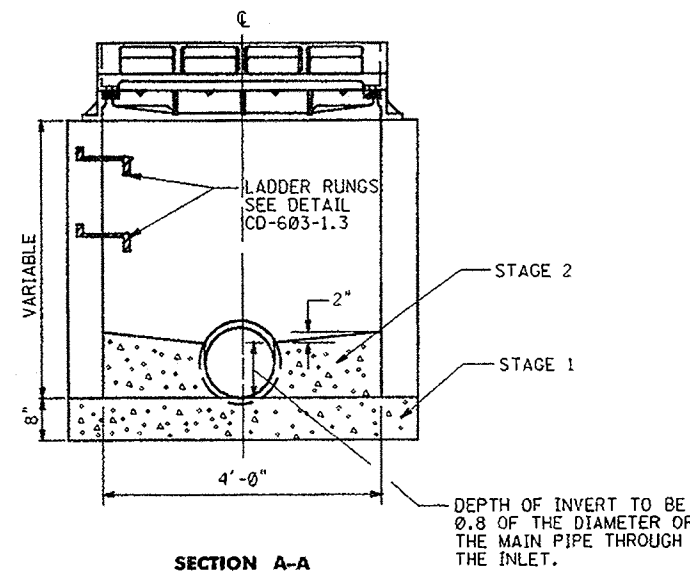

INLETS TYPE D-2

NOTE:
FOUNDATION AND INVERT TO BE CONSTRUCTED IN 2 STAGES
THE TOP SURFACE OF STAGE 1 TO BE LEFT ROUGH.

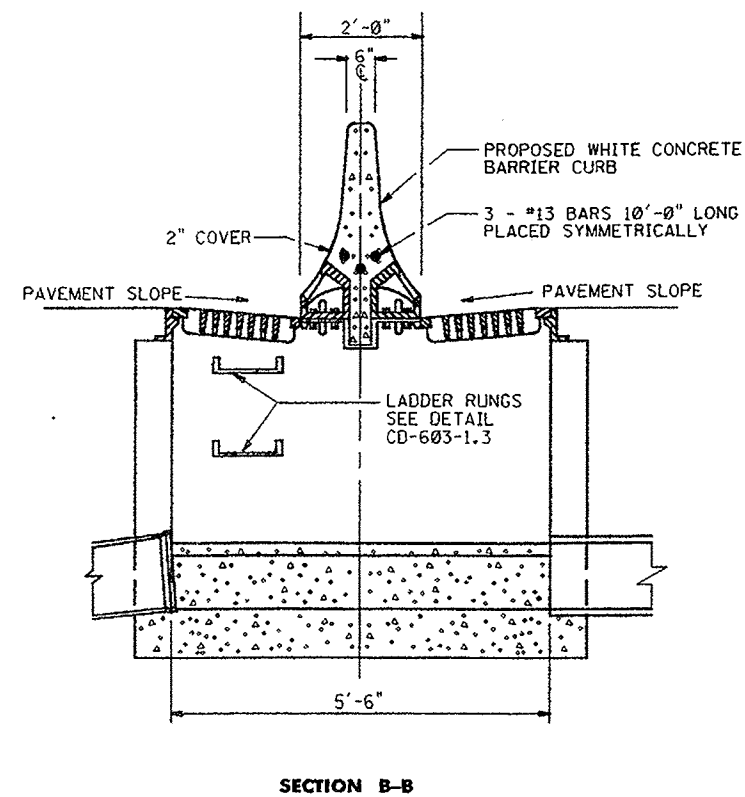

NOTES:
REINFORCING BARS ARE IN METRIC UNITS.

INLETS, TYPE D1 & D2

N.T.S.

CD-603-5

NEW JERSEY DEPARTMENT OF TRANSPORTATION

CONSTRUCTION DETAILS

CD-603-5.2

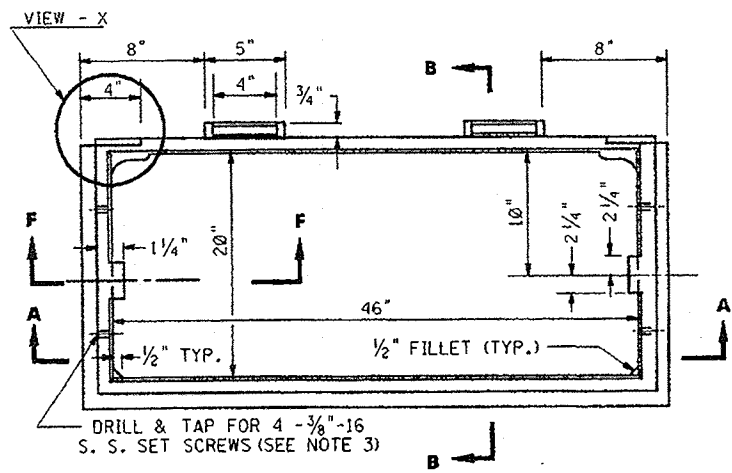

EXTENSION FRAMES FOR INLETS, TYPE B & C AND INLETS, TYPE D-1 & D-2

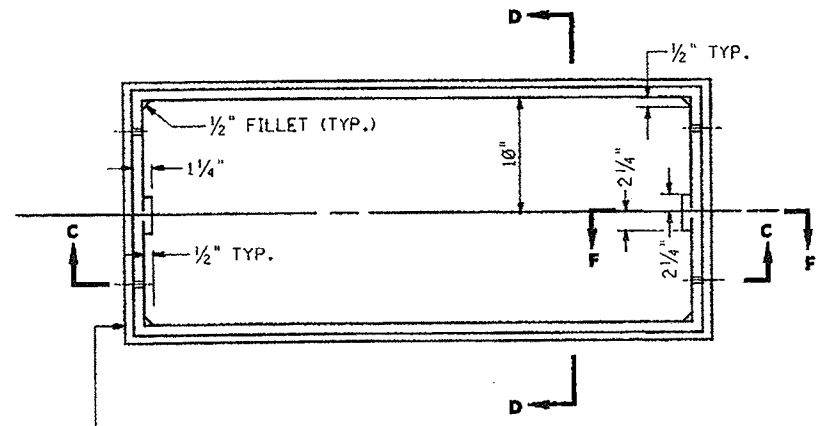

EXTENSION FRAMES FOR INLETS, TYPE A AND B MODIFIED

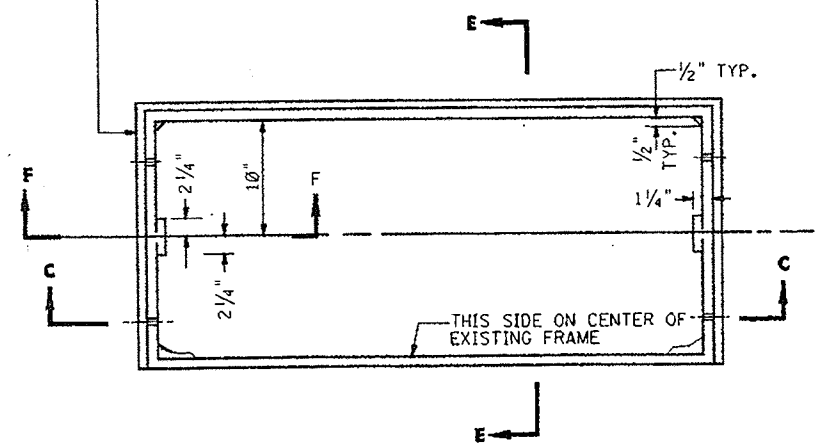

EXTENSION FRAMES FOR INLETS, TYPE E (HALF ONLY)

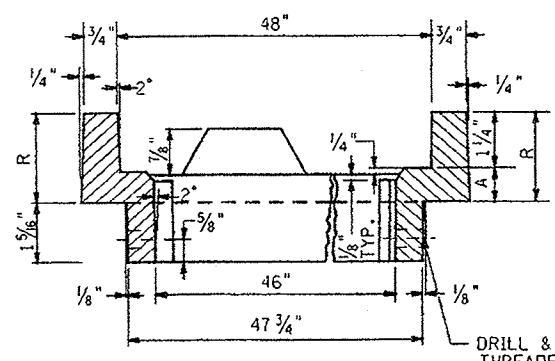

SECTION A-A

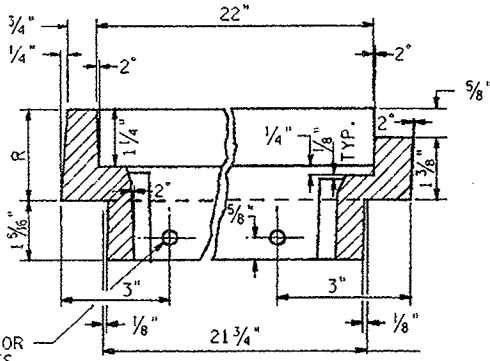

SECTION B-B

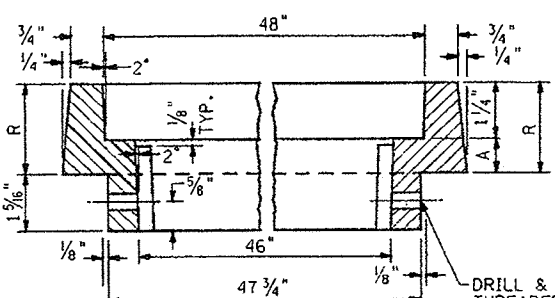

SECTION C-C

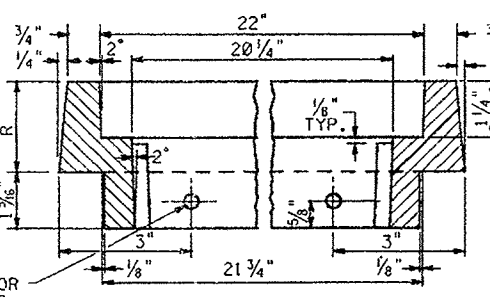

SECTION D-D

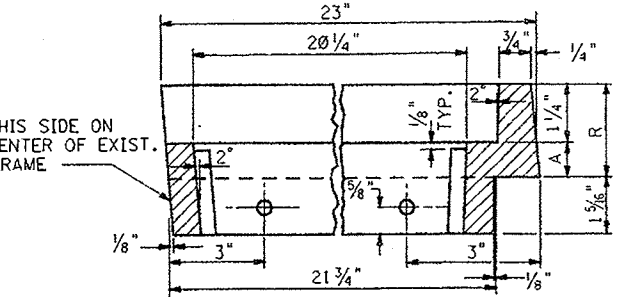

SECTION E-E

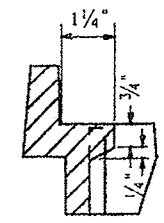

SECTION F-F

THIS LUG IS ONLY NECESSARY WHEN A BICYCLE SAFE-GRATE (CAST IRON) IS USED

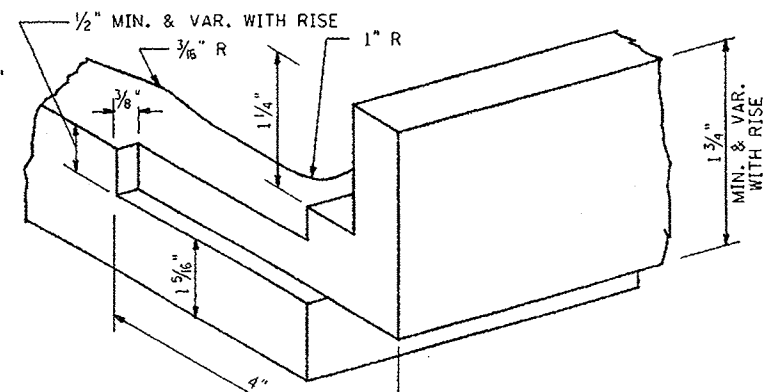

VIEW - X

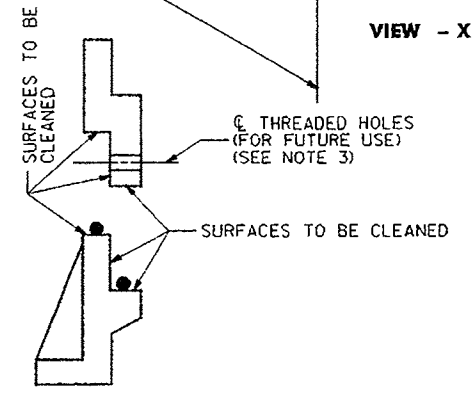

VIEW - Y

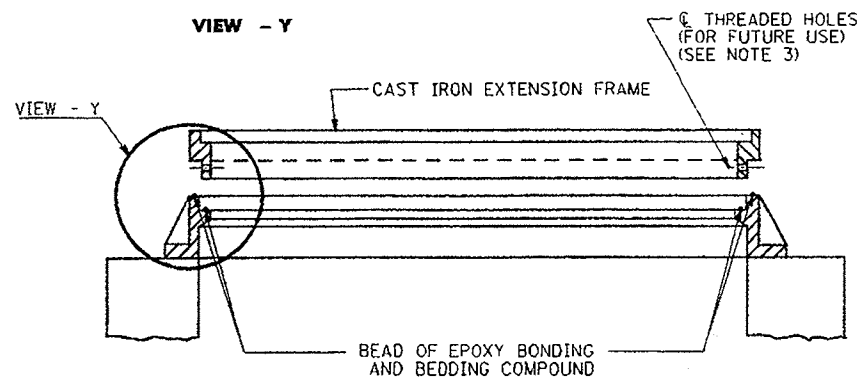

METHOD OF ATTACHING EXTENSION FRAMES

NOTES:

1. THE CONTRACTOR SHALL MEASURE THE EXISTING INLET FRAMES AND GRATES TO DETERMINE PROPER DIMENSIONS OF PROPOSED EXTENSION FRAMES BEFORE PLACING ORDER.
2. NOT TO BE USED WITH DISH GRATES.
3. A THREADED INSERT MAY BE USED AS AN ALTERNATE TO DRILLING AND TAPPING.

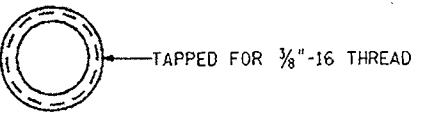
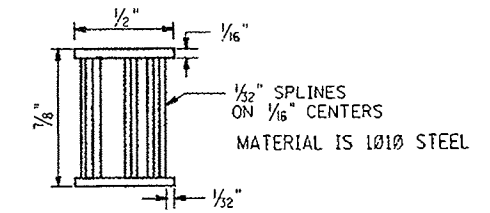

THREADED INSERT FOR EXTENSION FRAMES ALTERNATE

RISE=R	A
1 3/4"	1/2"
2"	3/4"
2 1/2"	1 1/4"
3"	1 3/4"
3 1/2"	2 1/4"

CAST IRON EXTENSION FRAMES FOR EXISTING INLETS

N.T.S.

NEW JERSEY DEPARTMENT OF TRANSPORTATION

CONSTRUCTION DETAILS

CD-603-6.1

CD-603-6

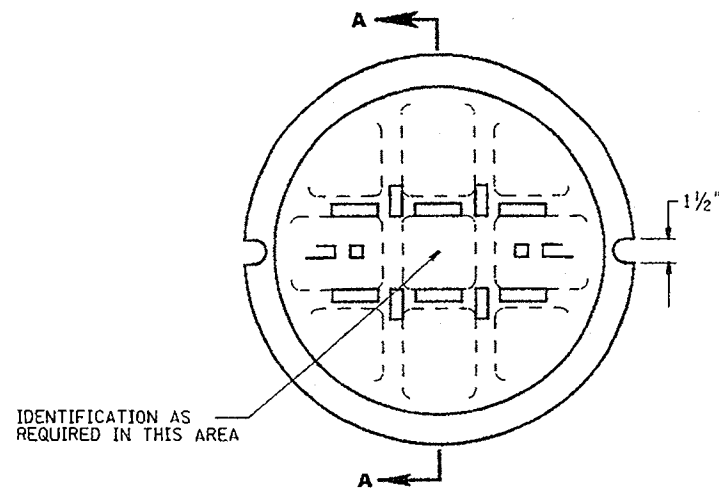

HEAVY DUTY COVER

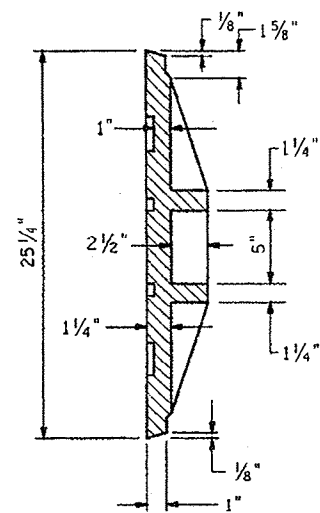

SECTION A-A

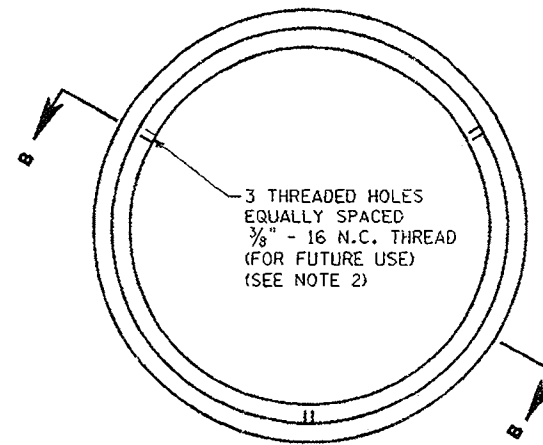

EXTENSION RING FOR STANDARD COVER

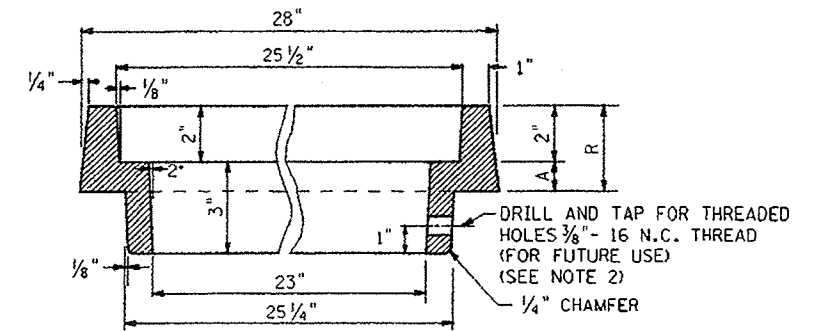

SECTION B-B

R=RISE	A
2 1/2"	1/2"
3"	1"
3 1/2"	1 1/2"

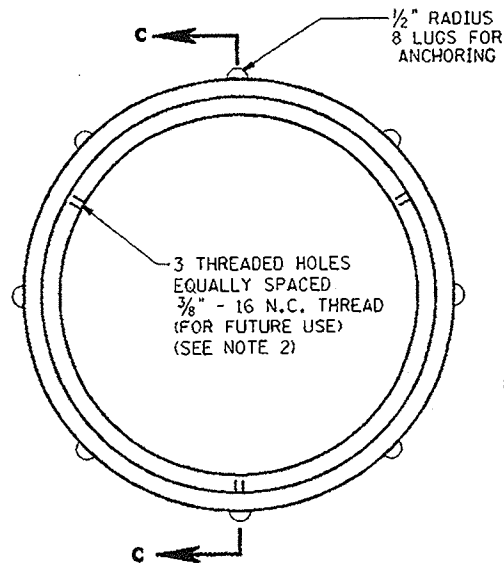

EXTENSION RING FOR HEAVY DUTY COVER
(SEE NOTE 3)

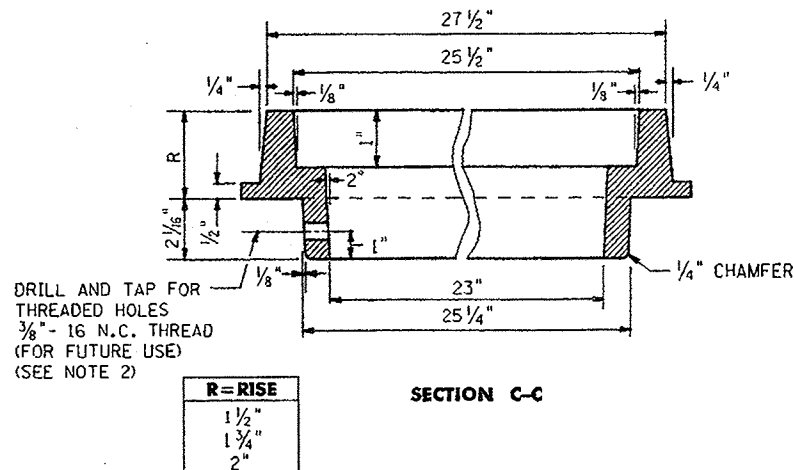

SECTION C-C

R=RISE
1 1/2"
1 3/4"
2"

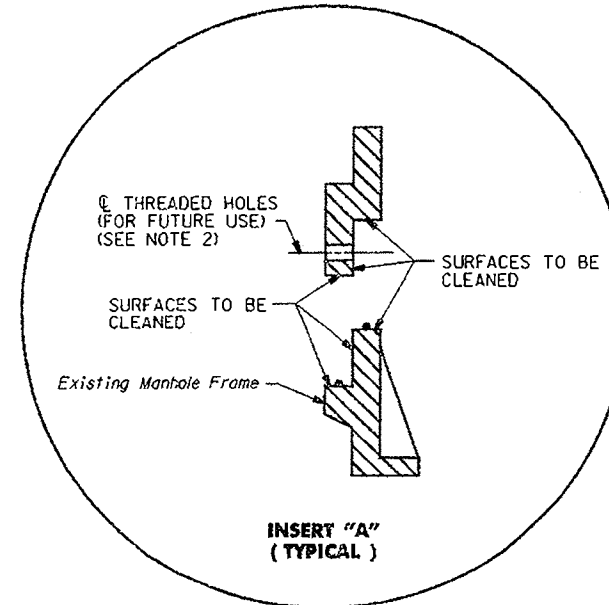

NOTES:

1. THE CONTRACTOR SHALL MEASURE THE EXISTING MANHOLE FRAMES AND COVERS TO DETERMINE PROPER DIMENSIONS OF PROPOSED EXTENSION RINGS BEFORE PLACING ORDER.
2. A THREADED INSERT MAY BE USED AS AN ALTERNATE TO DRILLING AND TAPPING.
3. A HEAVY DUTY COVER SHALL BE USED FOR A RISE OF 1 1/2" TO 2 1/4" INCLUSIVE.

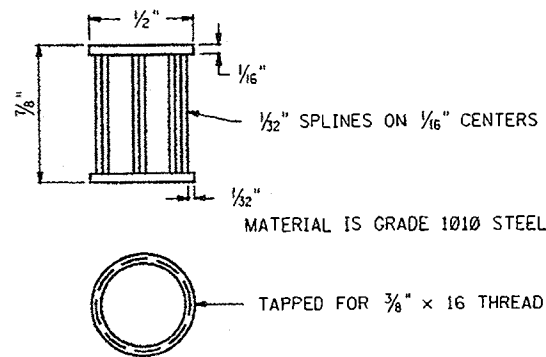

THREADED INSERT FOR EXTENSION RINGS, ALTERNATE

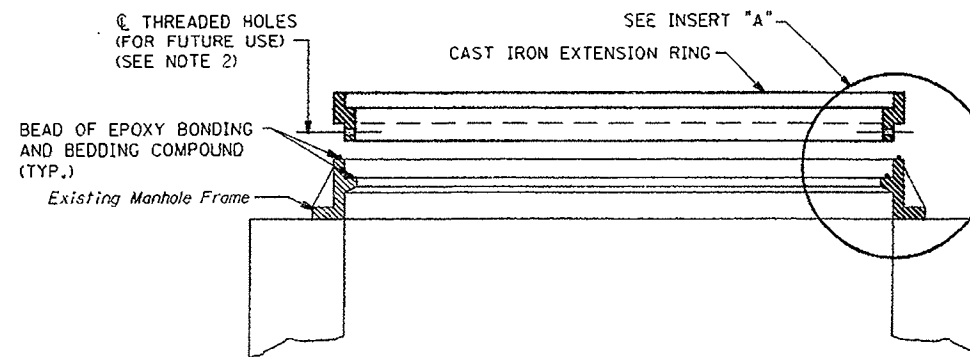

METHOD OF ATTACHING EXTENSION RINGS

CAST IRON EXTENSION RINGS FOR EXISTING MANHOLES

N.T.S.

CD-603-7

NEW JERSEY DEPARTMENT OF TRANSPORTATION

CONSTRUCTION DETAILS

CD-603-7.1

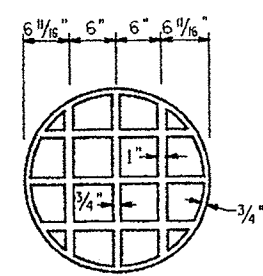
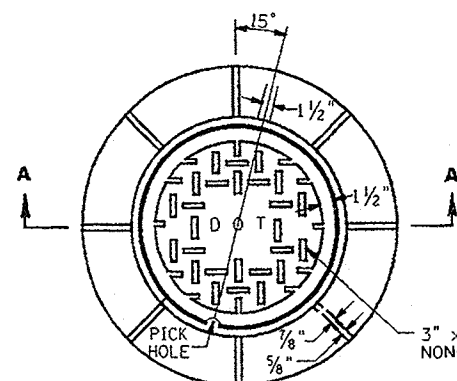

UNDERSIDE OF COVER

MINIMUM WEIGHTS
 WEIGHT OF FRAME = 265*
 WEIGHT OF COVER = 175*

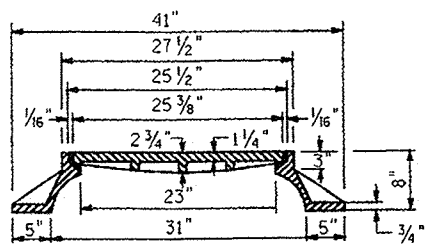

SECTION A-A

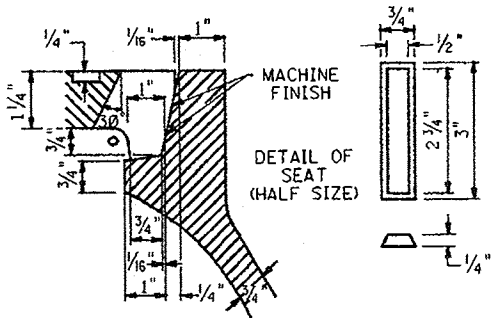

STANDARD MANHOLE FRAME AND COVER

CD-603-8.1

GENERAL NOTES

1. MANHOLES MAY BE CONSTRUCTED OF BRICK, CONCRETE, CONCRETE BLOCK, OR PRECAST CONCRETE.
2. WHEN THE DEPTH OF A MANHOLE EXCEEDS 10 FEET AS MEASURED FROM TOP OF COVER TO INVERT, THE WALLS OF BRICK, CONCRETE, OR CONCRETE BLOCK BELOW A DEPTH OF 8 FEET SHALL BE 12" THICK. THE OVERALL HORIZONTAL DIMENSIONS SHALL BE INCREASED 12" AND THE DEPTH OF THE FOUNDATION INCREASED TO 12". WHEN ROCK IS ENCOUNTERED THE HORIZONTAL DIMENSION AND DEPTH OF THE FOUNDATION SHALL NOT BE INCREASED. THE THICKNESS OF PRECAST CONCRETE MANHOLE WALLS DOES NOT HAVE TO BE INCREASED IF THE DEPTH OF THE MANHOLE EXCEEDS 10 FEET.
3. CASTINGS OF PRECAST MANHOLES SHALL BE ADJUSTED TO GRADE WITH COURSES OF BRICK OR CONCRETE BLOCK, AS REQUIRED, 12" MAXIMUM.
4. AS AN ALTERNATE TO THE STANDARD MANHOLE FRAME AND COVER, A 39" DIAMETER FRAME WITH 4" FLANGE MAY BE FURNISHED WITH ALL OTHER DIMENSIONS AND WEIGHTS REMAINING THE SAME.
5. IN A BRICK, CONCRETE, OR CONCRETE BLOCK MANHOLE, THE INVERT SHALL BE CONSTRUCTED IN TWO STAGES.
6. AS AN ALTERNATIVE, COPOLYMER POLYPROPYLENE PLASTIC LADDER RUNGS MY BE FURNISHED IN PRECAST MANHOLES AND INLETS.
7. STANDARD MANHOLE FRAME AND COVER SHOWN IN CD-603-8.1 SHALL BE DESIGNED FOR THE TRUCK LIVE LOAD (HS-25 TRUCK WHEEL LOAD) AS ADOPTED FOR NJDOT BRIDGES. IF THE AASHTO LRFD BRIDGE DESIGN SPECIFICATIONS ARE USED THEN THE DESIGN SHALL CONFORM TO THE AASHTO LRFD HL-93 VEHICULAR LIVE LOADING OR THE NJDOT PERMIT VEHICLE, WHICHEVER GOVERNS.

CD-603-8.3

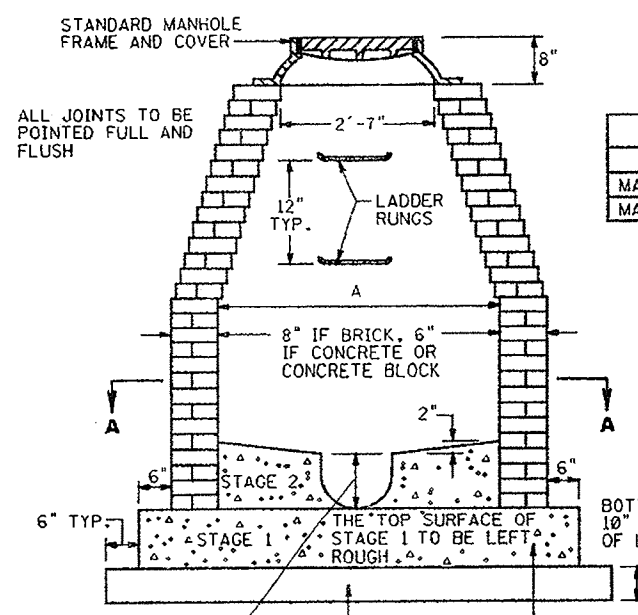

ITEM	DIMENSION A
MANHOLES	4'-0"
MANHOLES 5'-0" DIA.	5'-0"
MANHOLES 6'-0" DIA.	6'-0"

NOTE:
 DEPTH OF INVERT TO BE 0.80 OF THE DIAMETER OF THE MAIN SEWER THROUGH THE MANHOLE (TYP)

NOTE:
 FOUNDATION AND INVERT TO BE CONSTRUCTED IN TWO STAGES.

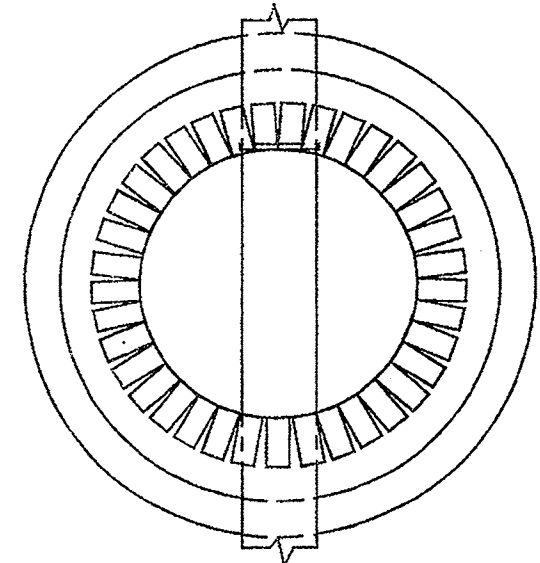

SECTION A-A

MANHOLES, MANHOLES 5 FOOT DIAMETER, MANHOLES 6 FOOT DIAMETER

CD-603-8.2

MANHOLES
 N.T.S.

CD-603-8

NEW JERSEY DEPARTMENT OF TRANSPORTATION

CONSTRUCTION DETAILS

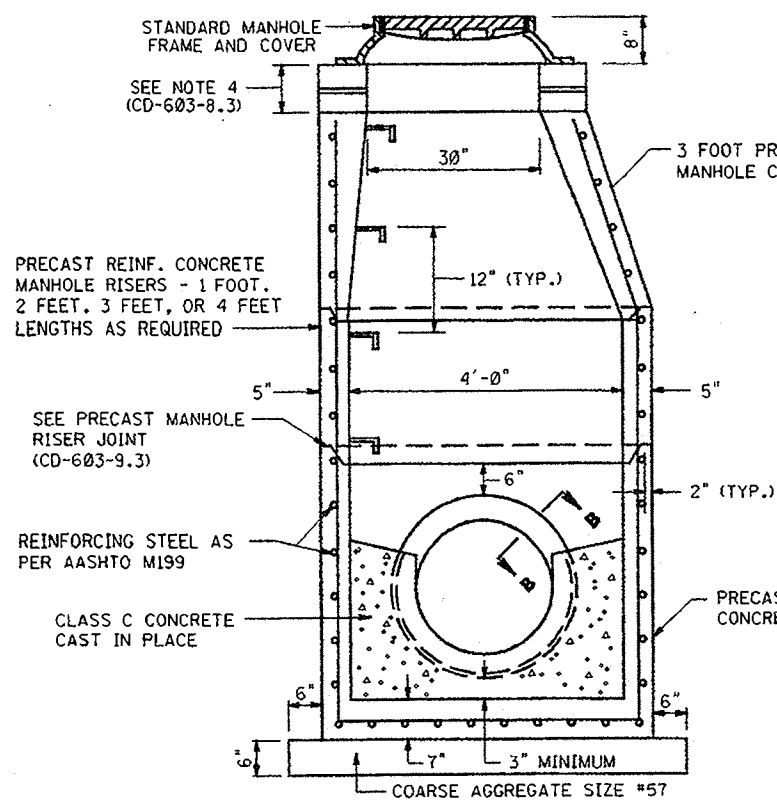

PRECAST REINFORCED CONCRETE MANHOLE SECTIONS SHALL CONFORM TO AASHTO M199

MANHOLES PRECAST CONCRETE

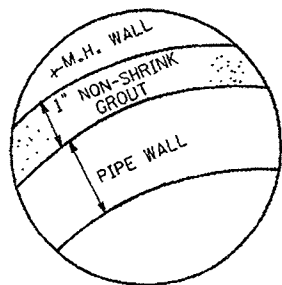

SECTION B-B

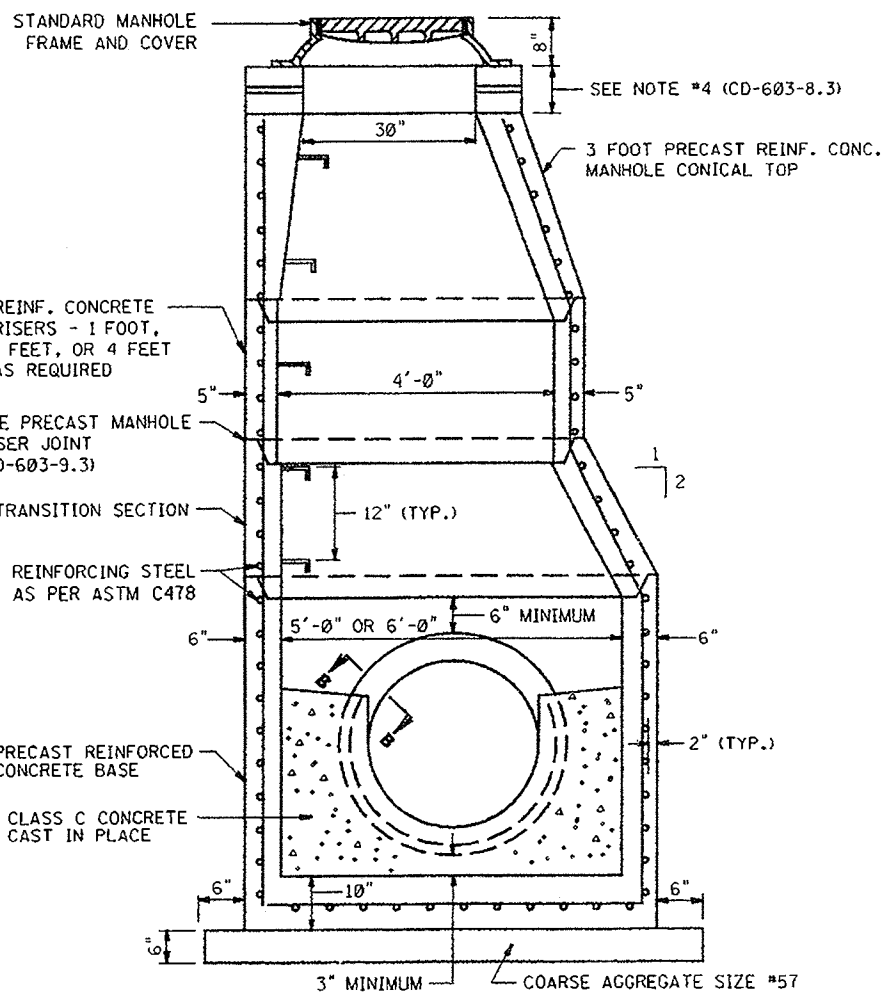

MANHOLES 5' DIAMETER, MANHOLES 6' DIAMETER PRECAST CONCRETE

CD-603-9.1

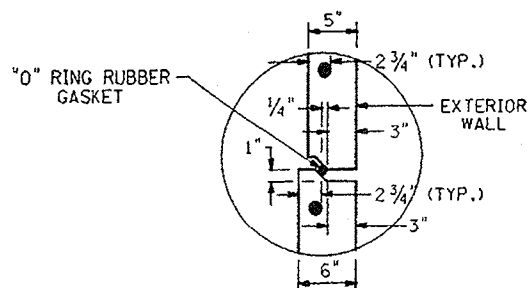

PRECAST MANHOLE RISER JOINT

CD-603-9.3

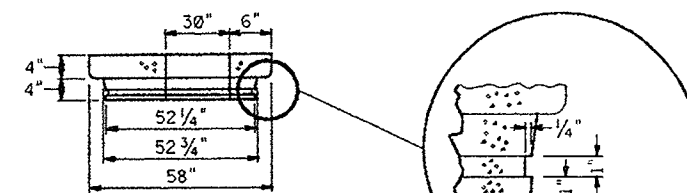

SECTION A-A

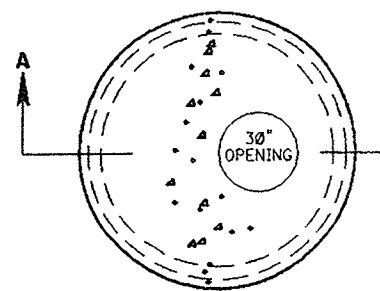

PLAN

GROOVE FOR "O" RING RUBBER GASKET

NOTE: USE IN LIEU OF CONICAL SECTION WHEN HEIGHT OF MANHOLE IS LESS THAN 4 FEET

48" PRECAST REINFORCED CONCRETE MANHOLE FLAT TOP

CD-603-9.2

PRECAST MANHOLES
N.T.S.

CD-603-9

NEW JERSEY DEPARTMENT OF TRANSPORTATION

CONSTRUCTION DETAILS

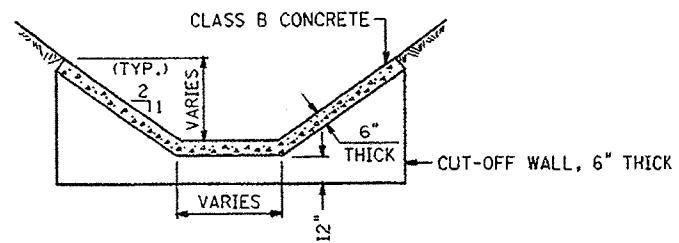

CONCRETE SLOPE GUTTERS, 6" THICK

NOTE:
 CONCRETE CUT-OFF WALLS SHALL BE CONSTRUCTED AT THE BEGINNING AND END OF EACH RUN OF GUTTER, EXCEPT WHERE THE GUTTER CONNECTS WITH A HEADWALL OR EXISTING GUTTER. THE COST OF CUT-OFF WALLS SHALL BE INCLUDED IN THE UNIT PRICE BID FOR CONCRETE SLOPE GUTTER, 6" THICK.

EXPANSION JOINTS SHALL BE 1/2" THICK AND SHALL BE SPACED AT INTERVALS OF 20 FEET. THE JOINTS SHALL BE FILLED WITH PREFORMED EXPANSION JOINT FILLER.

CD-604-1.1

CONCRETE SLOPE GUTTERS
 N.T.S.

CD-604-1

NEW JERSEY DEPARTMENT OF TRANSPORTATION

CONSTRUCTION DETAILS

GENERAL NOTES APPLYING TO ALL TYPES OF DOWELLED CURBS

TRANSVERSE JOINTS SHALL BE INSTALLED IN THE CURBS AT AND DIRECTLY OVER TRANSVERSE JOINTS IN THE PAVEMENT. DEFINITE CRACKS THRU THE PAVEMENT SHALL ALSO BE TREATED AS JOINTS. ADDITIONAL JOINTS SHALL ALSO BE CONSTRUCTED IN THE CURB SO SPACED AS TO MAKE EQUAL SECTIONS NOT OVER 15 FEET IN LENGTH.

THE TRANSVERSE JOINTS SHALL BE CONSTRUCTED AS SPECIFIED FOR THE CURB, EXCEPT THAT THE THICKNESS OF THE JOINT FILLER IN THE CURB SHALL BE AS FOLLOWS:

- 1/2" FOR INTERMEDIATE JOINTS AND JOINTS OVER DEFINITE CRACKS.
- 1/2" OVER PAVEMENT JOINTS WHERE SLAB LENGTH IS 50 FEET OR LESS.
- 1" OVER PAVEMENT JOINTS WHERE SLAB LENGTH IS MORE THAN 50 FEET VARIABLE IN MULTIPLES OF 1/2" BUT NOT LESS THAN THE EXISTING WIDTH OF THE TRANSVERSE JOINTS IN BRIDGES AND THE JOINTS BETWEEN THE APPROACH SLABS AND BRIDGES.

FOR THICKNESS OF 1" OR MORE, LAYERS OF 1/2" MATERIAL MAY BE GLUED OR OTHERWISE FASTENED TOGETHER BY A MEANS SATISFACTORY TO THE ENGINEER. WHERE THE REQUIRED JOINT OPENING EXCEEDS 1", THE CONTRACTOR MAY CONSTRUCT OPEN JOINTS, IF DESIRED.

WHERE THE CURB IS TO BE CONSTRUCTED ON EXISTING CONCRETE PAVEMENT SURFACE OR CONCRETE BASE COURSE, THE SURFACE OF THE CONCRETE PAVEMENT OR CONCRETE BASE SHALL BE CLEANED IN ACCORDANCE WITH STANDARD SPECIFICATIONS PRIOR TO CONSTRUCTION OF THE CURB THEREON.

WHERE DOWELLED CURB IS TO BE CONSTRUCTED ACROSS A LONGITUDINAL JOINT IN THE EXISTING PAVEMENT, THE DOWELS IN THE SHORTER PORTION OF THE CURB PANEL SHALL BE OMITTED AND THE CURB IN THIS PORTION OF THE PANEL SHALL BE CONSTRUCTED WITH 45° SMOOTH ROLL ROOFING BETWEEN IT AND THE EXISTING PAVEMENT.

CD-605-1.1

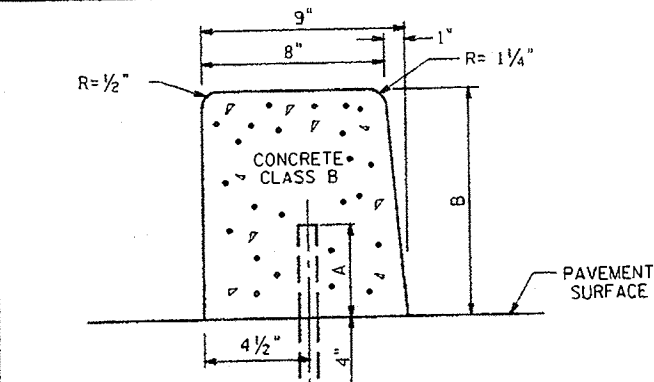

CURB SIZE	DIM. A	DIM. B
9' x 4'	2"	4"
9' x 6'	4"	6"

3/4" DIA. STEEL REINFORCING BARS 6" OR 8" LONG. DOWELS TO BE SET IN GROUT IN DRILLED HOLES. SPACED 4'-0" C. TO C. LONGITUDINALLY.

9' x 4' CONCRETE / WHITE CONCRETE VERTICAL CURB, DOWELLED

CD-605-1.2

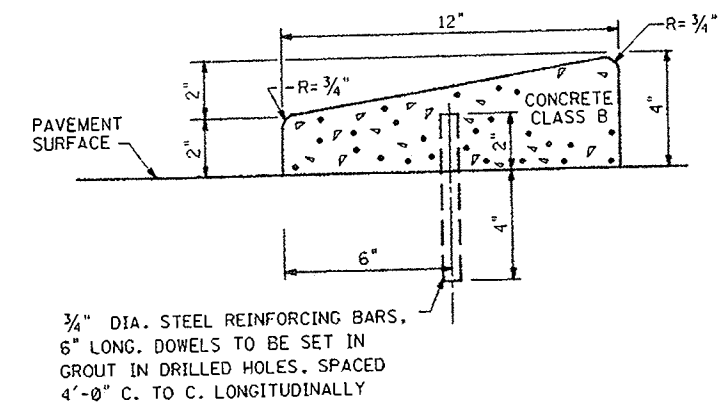

12' x 3' CONCRETE / WHITE CONCRETE SLOPING CURB, DOWELLED

CD-605-1.3

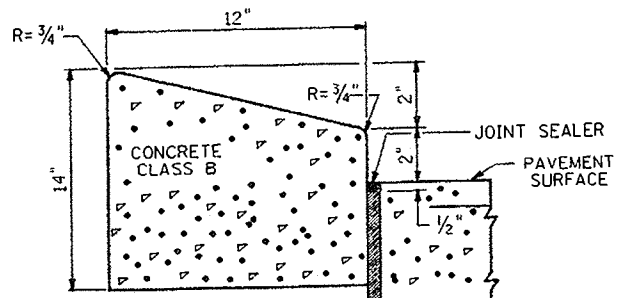

1/2" PREFORMED BITUMINOUS JOINT FILLER. DEPTH OF FILLER STRIP EQUALS PAVEMENT THICKNESS LESS 1/2". TO BE INSTALLED BETWEEN CURB AND CONCRETE PAVEMENT OR CONCRETE BASE COURSE.

12' x 13' CONCRETE / WHITE CONCRETE SLOPING CURB

CD-605-1.5

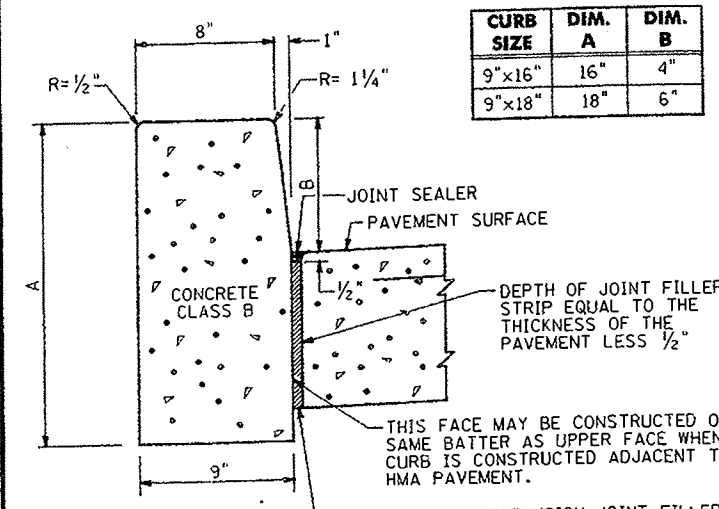

CURB SIZE	DIM. A	DIM. B
9' x 16'	16"	4"
9' x 18'	18"	6"

NOTES: TRANSVERSE JOINTS 1/2" WIDE SHALL BE INSTALLED IN THE CURB 20 FEET APART AND SHALL BE FILLED WITH PREFORMED BITUMINOUS-IMPREGNATED FIBER JOINT FILLER RECESSED 1/4" IN FROM FRONT FACE AND TOP OF CURB. EXPANSION JOINTS THRU AND ADJACENT TO THE CURB SHALL BE INCLUDED IN THE UNIT PRICE BID FOR CURB.

CONCRETE / WHITE CONCRETE VERTICAL CURB

CD-605-1.6

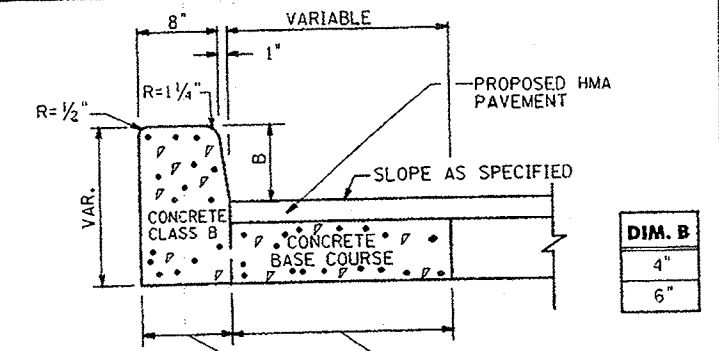

THIS PORTION TO BE PAID FOR AS CONCRETE / WHITE CONCRETE VERTICAL CURB. THIS PORTION TO BE PAID FOR AS CONCRETE BASE COURSE.

NOTES: EXPANSION JOINTS 1/2" WIDE IN THE CURB, AND EXPANSION JOINTS TYPE A IN THE MONOLITHIC PAVEMENT STRIP SHALL BE DIRECTLY OPPOSITE EVERY TRANSVERSE JOINT IN THE CENTRAL PAVEMENT STRIPS. JOINT MATERIAL IN THE CURB SHALL BE AS SPECIFIED FOR CONCRETE / WHITE CONCRETE VERTICAL CURB. THE TRANSVERSE EXPANSION JOINT MATERIAL SHALL NOT EXTEND THRU THE CURB.

CONCRETE / WHITE CONCRETE VERTICAL CURB MONOLITHIC WITH CONCRETE BASE COURSE

CD-605-1.4

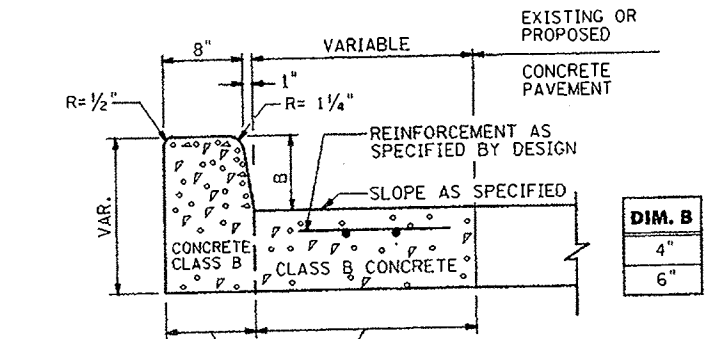

THIS PORTION TO BE PAID FOR AS CONCRETE / WHITE CONCRETE VERTICAL CURB. THIS PORTION TO BE PAID FOR AS CONCRETE SURFACE COURSE, REINFORCED, THICK.

NOTES: EXPANSION JOINTS 1/2" WIDE IN THE CURB, AND EXPANSION JOINTS TYPE A IN THE MONOLITHIC PAVEMENT STRIP SHALL BE DIRECTLY OPPOSITE EVERY TRANSVERSE JOINT IN THE CENTRAL PAVEMENT STRIPS. JOINT MATERIAL IN THE CURB SHALL BE AS SPECIFIED FOR CONCRETE / WHITE CONCRETE VERTICAL CURB. THE TRANSVERSE EXPANSION JOINT MATERIAL SHALL NOT EXTEND THRU THE CURB.

CONCRETE / WHITE CONCRETE VERTICAL CURB MONOLITHIC WITH CONCRETE PAVEMENT

CD-605-1.7

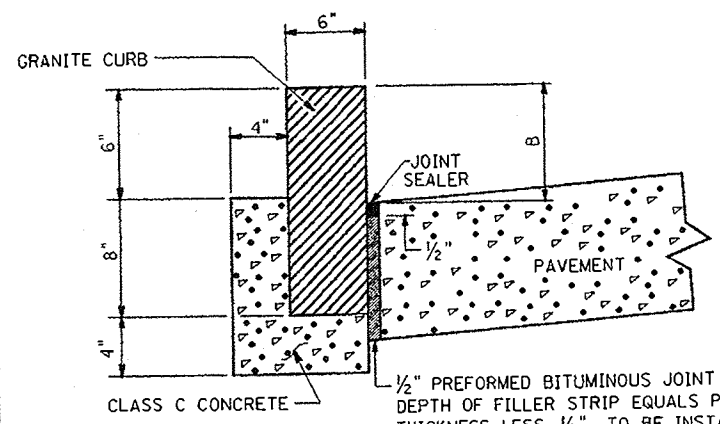

DIM. B
4"
6"

1/2" PREFORMED BITUMINOUS JOINT FILLER. DEPTH OF FILLER STRIP EQUALS PAVEMENT THICKNESS LESS 1/2". TO BE INSTALLED BETWEEN CURB AND CONCRETE PAVEMENT OR CONCRETE BASE COURSE.

NOTE: FOUNDATION TO BE INSTALLED THE ENTIRE LENGTH OF THE GRANITE CURB.

NEW OR RESET GRANITE CURB

CD-605-1.8

CD NO.	ATTACH. TYPE	WIDTH
612-13	B	11 1/4"
612-15	A	7"
612-15	B	11 1/4"
612-16	A	7"
612-16	B	11 1/4"

AT END OF CURB, TRANSITION TO 0" OVER 3'-14" (TOTAL LENGTH OF CURB 14'-0")

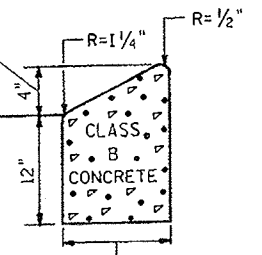

NOTE: PAYMENT FOR LIP CURB WILL BE MADE UNDER 9' x 4' CONCRETE / WHITE CONCRETE VERTICAL CURB.

LIP CURB

AT END OF CURB, TRANSITION TO 0" OVER 3'-14" (TOTAL LENGTH OF CURB 14'-0")

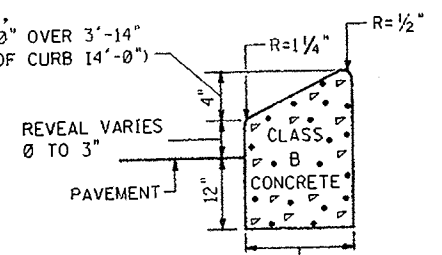

WIDTH IS 10 1/2" FOR CD 612-13, TYPE (A) ATTACHMENT ONLY.

CD-605-1.9

CONCRETE AND GRANITE CURB

N.T.S.

NOTES: REINFORCING BARS ARE IN METRIC UNITS. HMA = HOT ASPHALT MIX

CD-605-1

NEW JERSEY DEPARTMENT OF TRANSPORTATION

CONSTRUCTION DETAILS

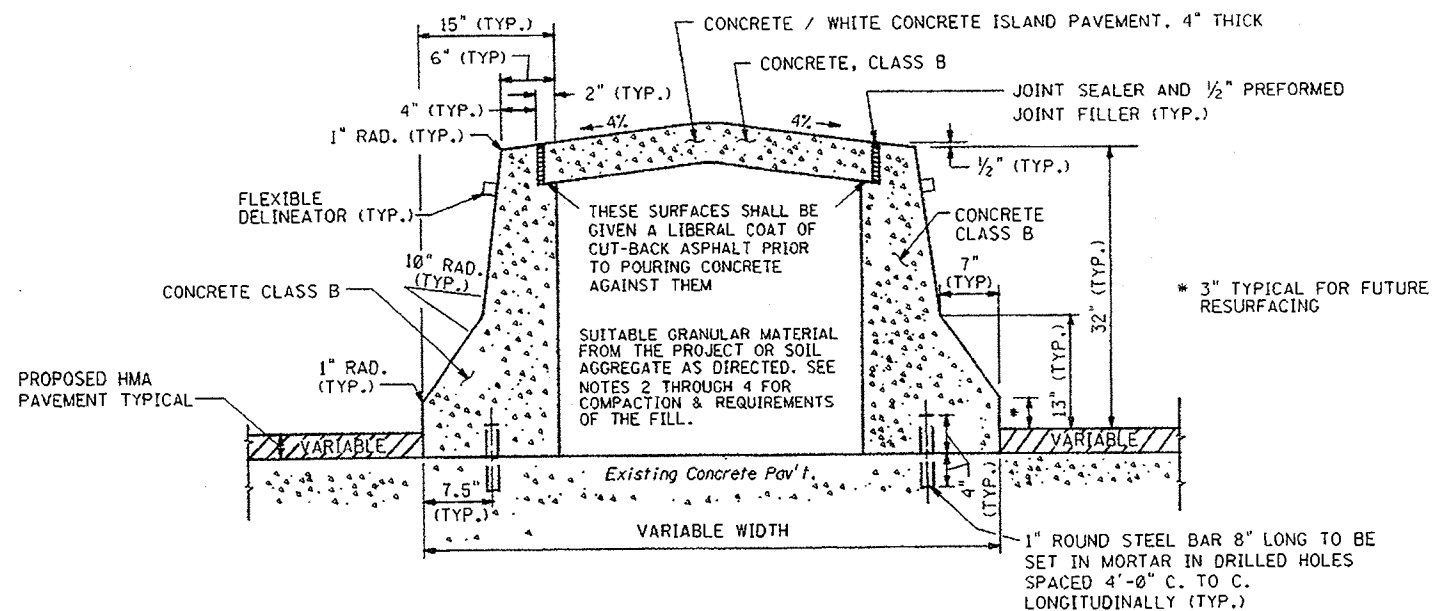

15" x VARIABLE HEIGHT CONCRETE / WHITE CONCRETE BARRIER CURB, DOWELED

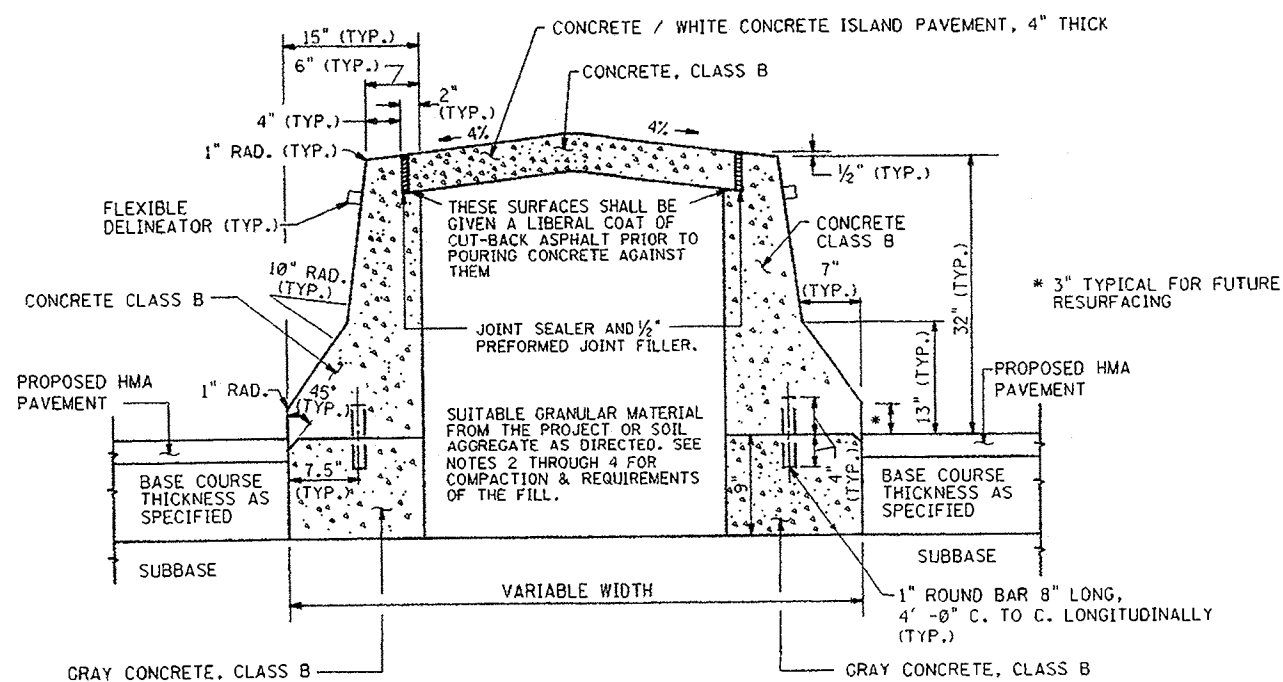

15" x 41" CONCRETE / WHITE CONCRETE BARRIER CURB

NOTES:

1. SEE GENERAL NOTES APPLYING TO ALL BARRIER CURB CD-605-3.2.
2. COMPACTION SHALL BE IN ACCORDANCE WITH THE DENSITY CONTROL METHOD OF THE NJDOT STANDARD SPECIFICATIONS AND ITS SUPPLEMENTS.
3. THE FILL BETWEEN THE CURBS SHALL BE SHAPED AND COMPACTED TO A FIRM EVEN SURFACE. UNSTABLE MATERIAL SHALL BE REMOVED AND REPLACED WITH ACCEPTABLE MATERIAL WHICH SHALL BE COMPACTED.
4. SOIL LIFTS SHALL BE LIMITED TO 12 INCHES AND EACH LIFT SHALL BE COMPACTED.
5. THE ITEM FLEXIBLE DELINEATORS, BARRIER CURB MOUNTED SHALL BE INSTALLED ON ALL BARRIER CURB IN ACCORDANCE WITH SECTION 620 OF THE N.J.D.O.T. SPECIFICATIONS.

CD-605-2.1

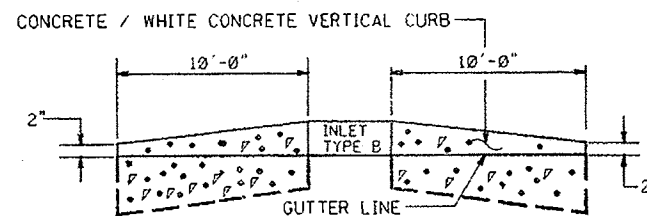

CURB TREATMENT AT BERM SECTION AND ALL CURB ENDS

CD-605-2.2

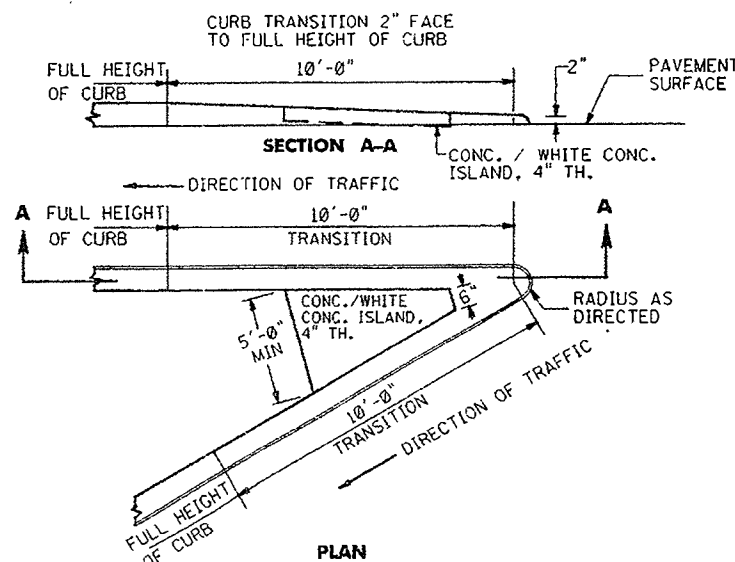

CURB TRANSITION

CD-605-2.3

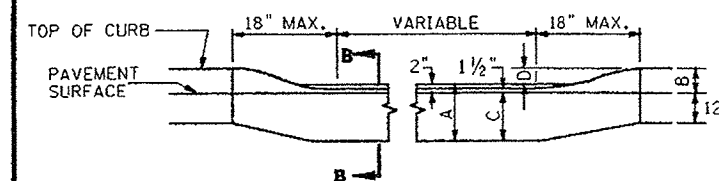

SECTION B-B

CURB SIZE	DIM. A	DIM. B	DIM. C	DIM. D
9" x 16"	16"	4"	14"	2"
9" x 18"	18"	6"	16"	4"

METHOD OF DEPRESSING CURB AT DRIVEWAYS

CD-605-2.4

BARRIER CURB AND VERTICAL CURB DETAILS

N.T.S.

HMA = HOT ASPHALT MIX

CD-605-2

NEW JERSEY DEPARTMENT OF TRANSPORTATION

CONSTRUCTION DETAILS

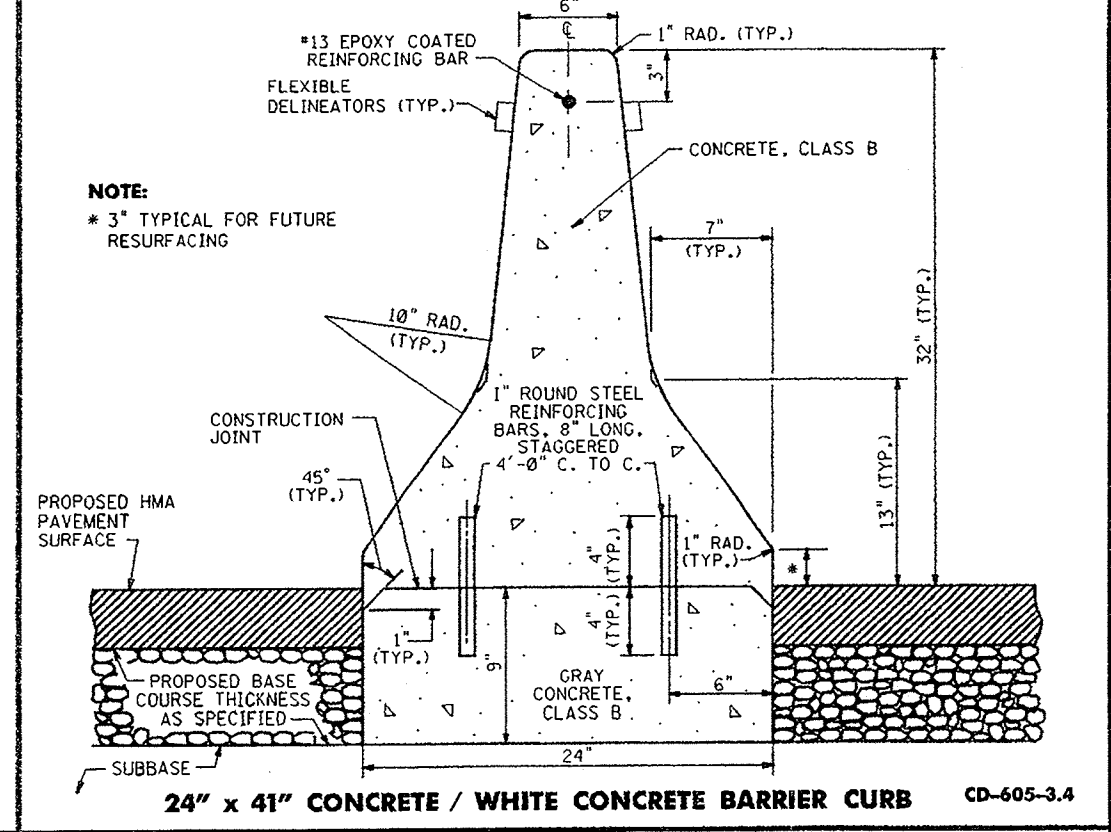
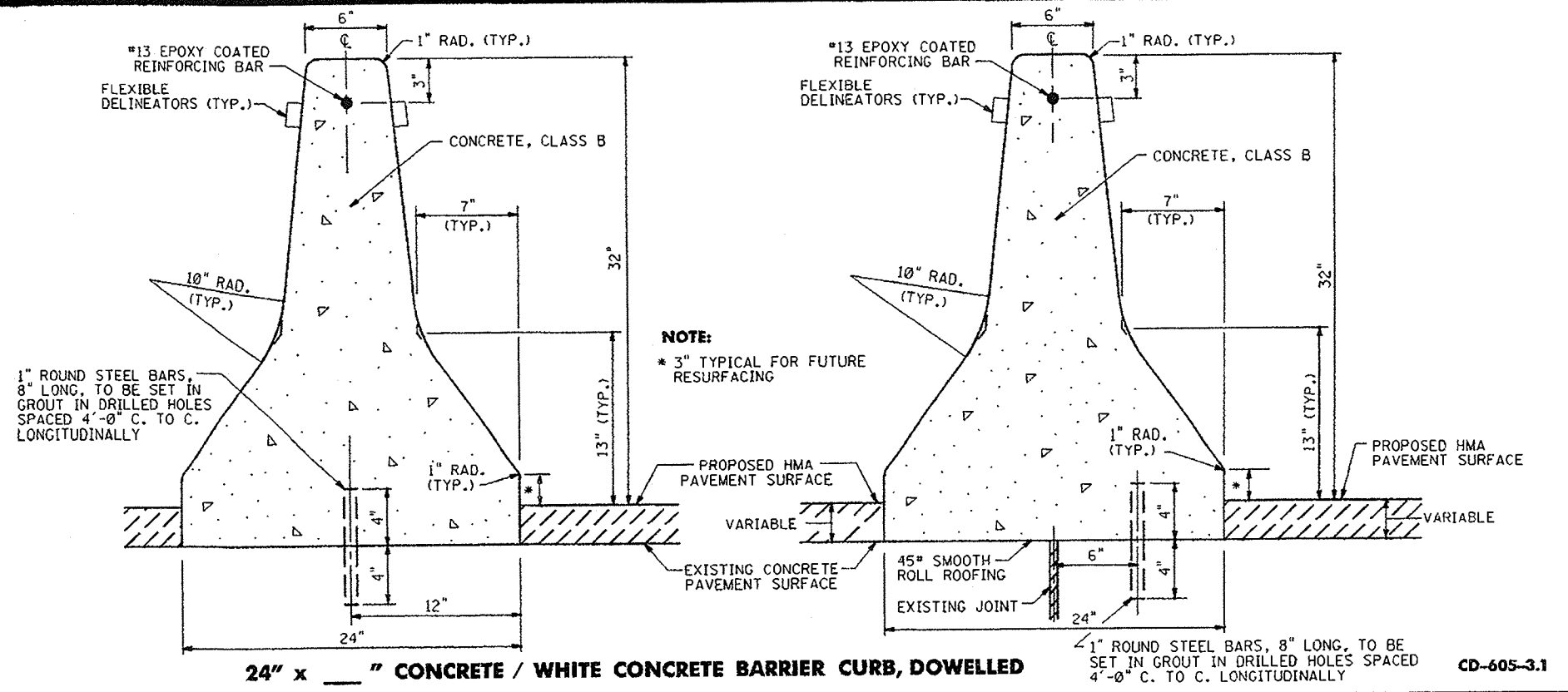

GENERAL NOTES

(A) WHERE BARRIER CURB, DOWELLED, IS TO BE CONSTRUCTED ON EXISTING CONCRETE PAVEMENT OR EXISTING CONCRETE BASE COURSE

TRANSVERSE JOINTS SHALL BE INSTALLED IN THE CURBS AT AND DIRECTLY OVER TRANSVERSE JOINTS IN THE PAVEMENT. DEFINITE CRACKS THROUGH THE PAVEMENT SHALL ALSO BE TREATED AS JOINTS. ADDITIONAL JOINTS SHALL ALSO BE CONSTRUCTED IN THE CURB SO SPACED AS TO MAKE EQUAL SECTIONS NOT OVER 15'-0" IN LENGTH.

THE TRANSVERSE JOINTS SHALL BE FILLED WITH PREFORMED BITUMINOUS-IMPREGNATED FIBER JOINT FILLER, COMPLYING WITH THE REQUIREMENTS OF AASHTO M-213 SPECIFICATION, RECESSED 1/4" IN FROM FACES AND TOP OF CURB. THE COST OF THE TRANSVERSE EXPANSION JOINTS IN THE CURB SHALL BE INCLUDED IN THE UNIT PRICE BID FOR THE BARRIER CURB. THE THICKNESS OF THE TRANSVERSE EXPANSION JOINT FILLER SHALL BE AS FOLLOWS:

1/2" FOR IMMEDIATE JOINTS AND JOINTS OVER DEFINITE CRACKS.
1/2" OVER PAVEMENT JOINTS WHERE SLAB LENGTH IS 50 FEET OR LESS.
1" OVER PAVEMENT JOINTS WHERE SLAB LENGTH IS MORE THAN 50 FEET.

VARIABLE IN MULTIPLES OF 1/2" BUT NOT LESS THAN THE EXISTING WIDTH OF THE TRANSVERSE JOINTS IN BRIDGES AND JOINTS BETWEEN THE APPROACH SLABS AND BRIDGES.

THE THICKNESS OF 1 INCH OR MORE, LAYERS OF 1/2" MATERIAL MAY BE GLUED OR OTHERWISE FASTENED TOGETHER BY A MEANS SATISFACTORY TO THE ENGINEER. WHERE THE REQUIRED JOINT OPENING EXCEEDS 1 INCH, THE CONTRACTOR MAY CONSTRUCT OPEN JOINTS.

THE SURFACE OF THE EXISTING CONCRETE PAVEMENT OR CONCRETE BASE COURSE SHALL BE CLEANED IN ACCORDANCE WITH THE NJDOT SPECIFICATIONS PRIOR TO THE CONSTRUCTION OF THE CURB THEREON.

(A) CONT.

WHERE DOWELLED CURB IS TO BE CONSTRUCTED ACROSS A LONGITUDINAL JOINT IN THE EXISTING CONCRETE OR BASE COURSE, THE DOWELS IN THE SHORTER PORTION OF THE CURB PANEL SHALL BE OMITTED AND THE CURB IN THIS PORTION OF THE PANEL SHALL BE CONSTRUCTED WITH 45° SMOOTH ROLL ROOFING BETWEEN IT AND THE EXISTING PAVEMENT.

(B) WHERE BARRIER CURB IS TO BE CONSTRUCTED ON PROPOSED CONCRETE BASE.

TRANSVERSE JOINTS 1/2" WIDE SHALL BE INSTALLED IN THE BASE 20'-0" APART AND IN THE BARRIER CURB DIRECTLY OVER JOINTS IN THE BASE. THE JOINTS SHALL BE FILLED WITH PREFORMED BITUMINOUS-IMPREGNATED FIBER JOINT FILLER, COMPLYING WITH THE REQUIREMENTS OF AASHTO M-213 SPECIFICATION, RECESSED 1/4" IN FROM FACES AND TOP OF CURB. THE COST OF THE TRANSVERSE EXPANSION JOINTS IN THE BASE AND IN THE CURB SHALL BE INCLUDED IN THE UNIT PRICE FOR THE BARRIER CURB.

(C) GENERAL

THE FINISHED SURFACE OF THE BARRIER CURB SHALL BE SMOOTH, DENSE UNPITTED AND FREE FROM AIR BUBBLE POCKETS, DEPRESSIONS, AND HONEYCOMBS. IF THE ENGINEER DEEMS IT NECESSARY, THE CURB SHALL BE GIVEN A WOOD FLOAT FINISH RUBBED WITH A MIXTURE OF CEMENT, SAND, AND WATER TO OBTAIN THE ABOVE-MENTIONED FINISHED SURFACE.

(D) DELINEATORS

THE ITEM FLEXIBLE DELINEATORS, BARRIER CURB MOUNTED SHALL BE INSTALLED ON ALL BARRIER CURB IN ACCORDANCE WITH SECTION 620 OF THE N.J.D.O.T. SPECIFICATIONS.

CD-605-3.2

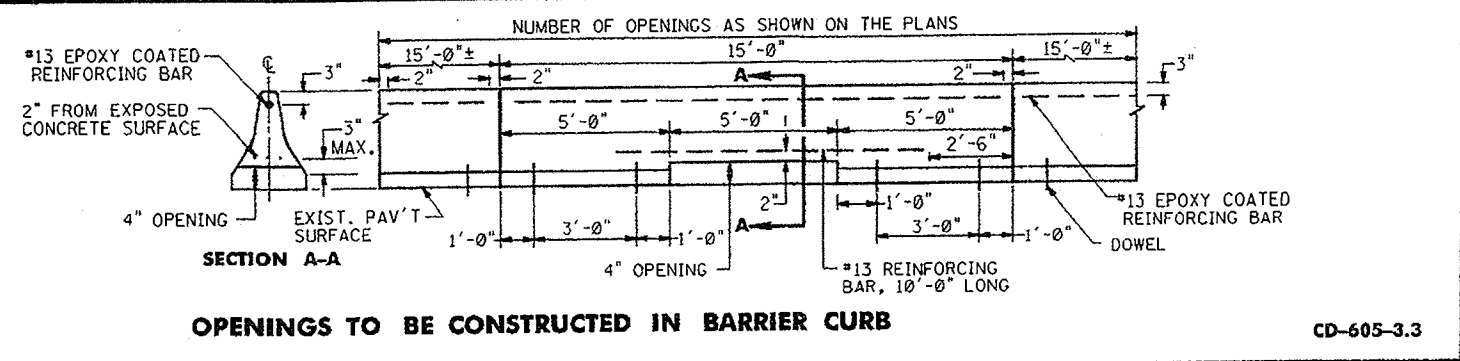
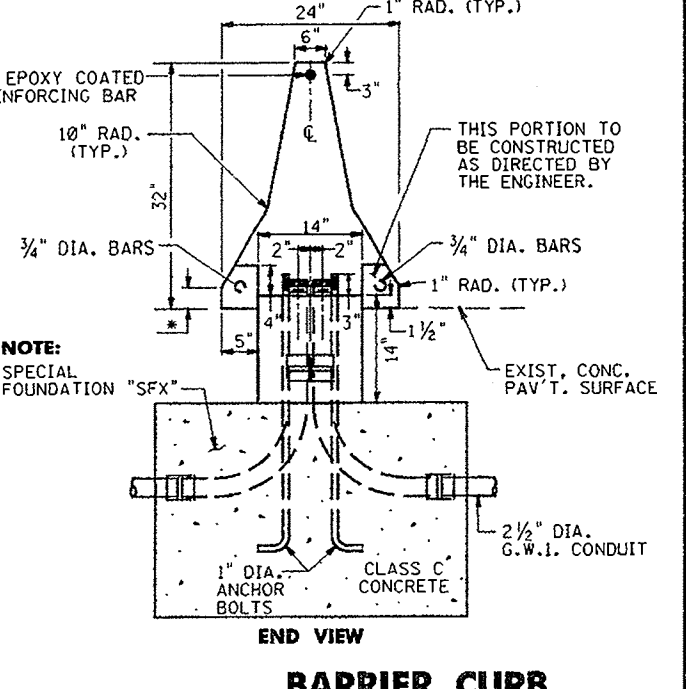
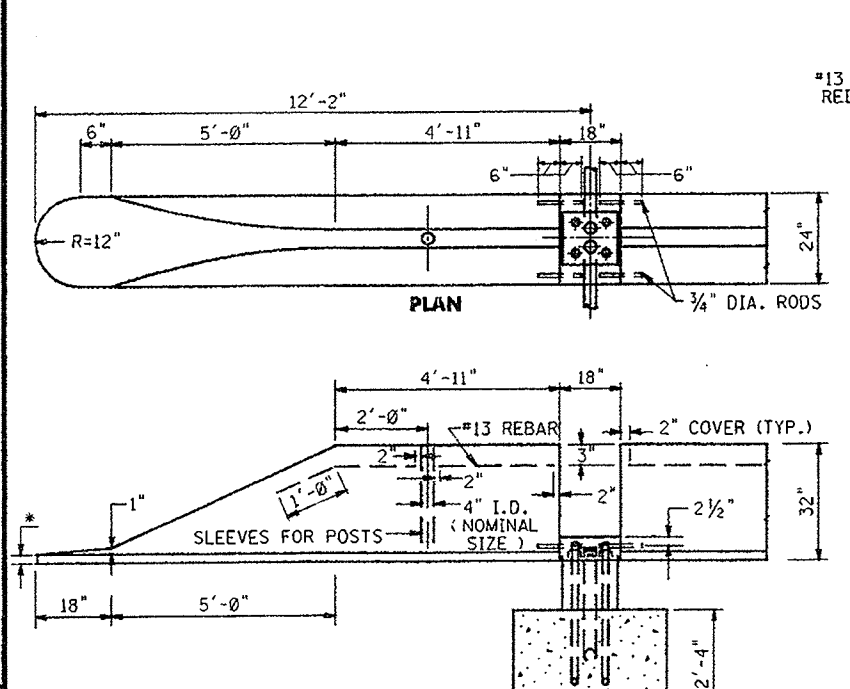

NOTES:
REINFORCING BARS ARE IN METRIC UNITS.
HMA = HOT ASPHALT MIX

BARRIER CURB AT LIGHTING POLE BASE INSTALLATION

CD-605-3.5

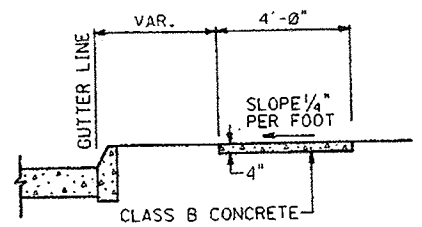

CONCRETE SIDEWALK, 4" THICK

CD-607-1.1

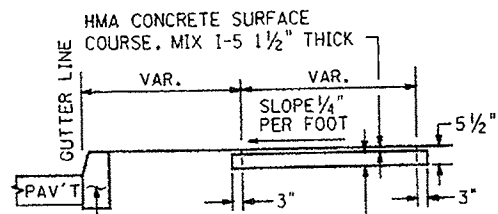

HMA SIDEWALK, 5 1/2" THICK

CD-607-1.2

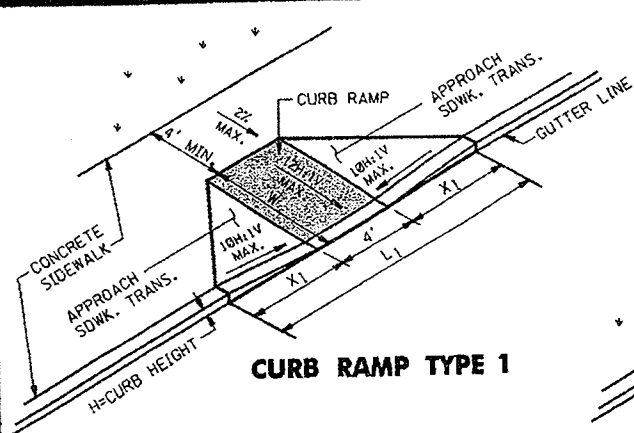

CURB RAMP TYPE 1

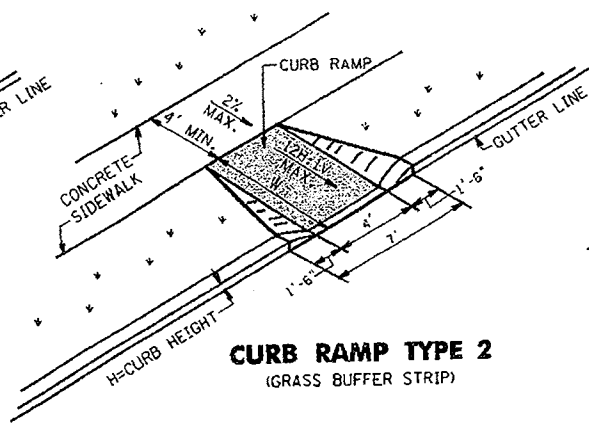

CURB RAMP TYPE 2
(GRASS BUFFER STRIP)

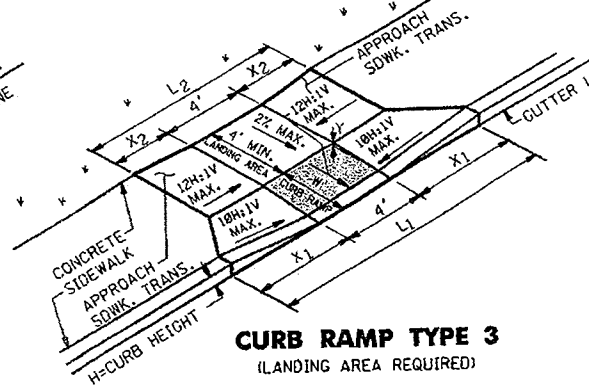

CURB RAMP TYPE 3
(LANDING AREA REQUIRED)

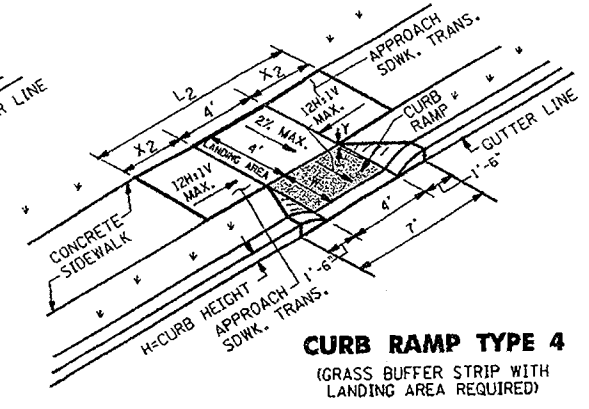

CURB RAMP TYPE 4
(GRASS BUFFER STRIP WITH LANDING AREA REQUIRED)

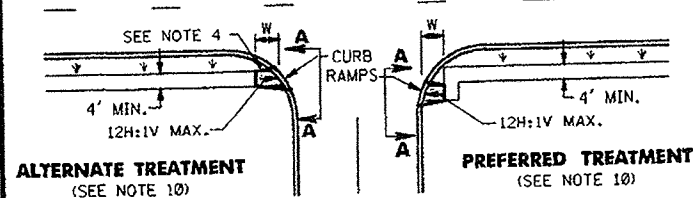

ALTERNATE TREATMENT
(SEE NOTE 10)

PREFERRED TREATMENT
(SEE NOTE 10)

CURB RAMP TYPE 5

(CROSSING PARALLEL TO HIGHWAY ONLY)

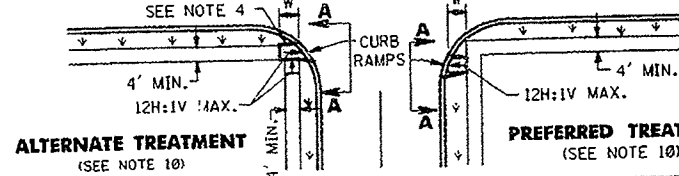

ALTERNATE TREATMENT
(SEE NOTE 10)

PREFERRED TREATMENT
(SEE NOTE 10)

CURB RAMP TYPE 6

(CROSSING PARALLEL TO HIGHWAY ONLY)

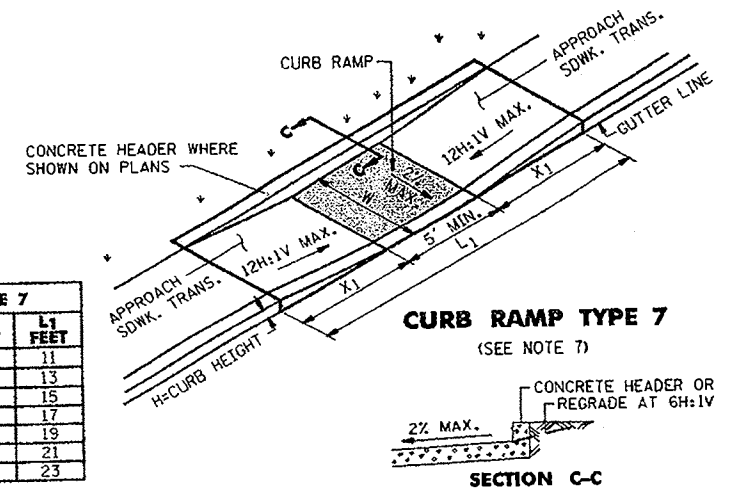

CURB RAMP TYPE 7

(SEE NOTE 7)

CURB RAMP TYPE 7			
W FEET	H INCHES	X1 FEET	L1 FEET
4 MIN.	3	3	11
6 MAX.	4	4	13
	5	5	15
	6	6	17
	7	7	19
	8	8	21
	9	9	23

SECTION C-C

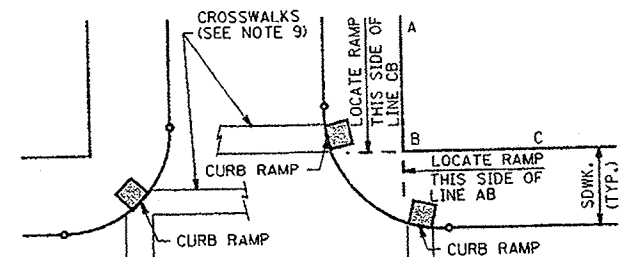

ALTERNATE TREATMENT
(SEE NOTE 10)

PREFERRED TREATMENT
(SEE NOTE 10)

LOCATION OF CURB RAMP TYPES 1, 2, 3, 4 & 7 FOR CROSSING PARALLEL AND PERPENDICULAR TO HIGHWAY

CURB RAMP TYPE 1			
H INCHES	X1 FEET	L1 FEET	W FEET
3	2.5	9.0	3
4	3.3	10.6	4
5	4.2	12.4	5
6	5.0	14.0	6
7	5.8	15.6	7
8	6.7	17.4	8
9	7.5	19.0	9

CURB RAMP TYPE 2, 5 OR 6	
H INCHES	W FEET
3	3
4	4
5	5
6	6
7	7
8	8
9	9

CURB RAMP TYPE 3						
W FEET	H INCHES	X1 FEET	L1 FEET	Y INCHES	X2 FEET	L2 FEET
2.5	3	2.5	9	2.5	0.5	5
	4	3.3	10.6	2.5	1.5	7
	5	4.2	12.4	2.5	2.5	9
	6	5.0	14.0	2.5	3.5	11
	7	5.8	15.6	2.5	4.5	13
	8	6.7	17.4	2.5	5.5	15
3.0	3	3	10.6	3	0.5	6
	4	3.3	10.6	3.0	1	6
	5	4.2	12.4	3.0	2	8
	6	5.0	14.0	3.0	3	10
	7	5.8	15.6	3.0	4	12
	8	6.7	17.4	3.0	5	14
3.5	3	3	10.6	3.5	0.5	5
	4	3.3	10.6	3.5	1.5	7
	5	4.2	12.4	3.5	2.5	9
	6	5.0	14.0	3.5	3.5	11
	7	5.8	15.6	3.5	4.5	13
	8	6.7	17.4	3.5	5.5	15
4.0	3	3	10.6	4	0.5	5
	4	3.3	10.6	4.0	1	6
	5	4.2	12.4	4.0	2	8
	6	5.0	14.0	4.0	3	10
	7	5.8	15.6	4.0	4	12
	8	6.7	17.4	4.0	5	14

* NOTE: TYPE 3 RAMP IS NOT APPLICABLE, USE TYPE 1.

CURB RAMP TYPE 4				
W FEET	H INCHES	Y INCHES	X2 FEET	L2 FEET
2.5	3	2.5	0.5	5
	4	2.5	1.5	7
	5	2.5	2.5	9
	6	2.5	3.5	11
	7	2.5	4.5	13
	8	2.5	5.5	15
3.0	3	**	**	**
	4	3.0	1	6
	5	3.0	2	8
	6	3.0	3	10
	7	3.0	4	12
	8	3.0	5	14
3.5	3	**	**	**
	4	3.5	0.5	5
	5	3.5	1.5	7
	6	3.5	2.5	9
	7	3.5	3.5	11
	8	3.5	4.5	13
4.0	3	**	**	**
	4	**	**	**
	5	4.0	1	6
	6	4.0	2	8
	7	4.0	3	10
	8	4.0	4	12

** NOTE: TYPE 4 RAMP IS NOT APPLICABLE, USE TYPE 2.

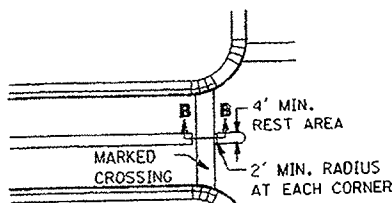

NOTE: WHERE PRACTICAL, END LEFT TURN ISLAND OR DIVISIONAL ISLAND BEFORE CROSSWALK TO ELIMINATE CUT-THROUGH

ISLAND WALKWAY OPENING AT INTERSECTIONS

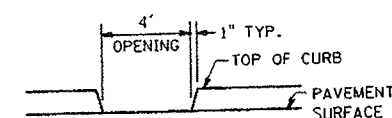

NOTE: 4' WIDE OPENING TO BE FLUSH WITH ROADWAY PAVEMENT

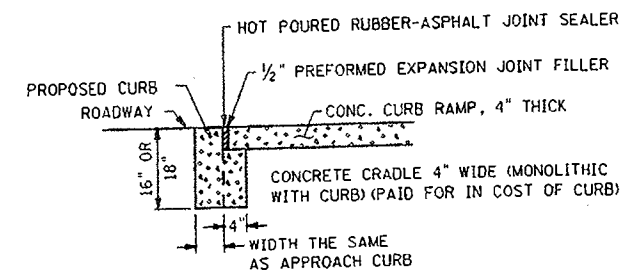

DROPPED CURB AND CRADLE

CURB RAMP

- GENERAL NOTES:**
- LANDING AREA, APPROACH SIDEWALK TRANSITIONS, AND CURB RAMP SHALL BE KEPT CLEAR OF OBSTRUCTIONS.
 - DIMENSIONS SHOWN IN TABLES ARE FOR RELATIVELY FLAT SIDEWALK AREAS. CARE SHOULD BE TAKEN WHEN DETERMINING CURB RAMP SIZE BASED ON CURB HEIGHT (H) WHERE ELEVATION OF CURB AND SIDEWALK VARY DRASTICALLY IN AREA OF PROPOSED CURB RAMP.
 - CURB (DROPPED CURB) GUTTERLINE TO BE FLUSH WITH ROADWAY PAVEMENT A MINIMUM OF 4 FEET AT ALL CURB RAMP, EXCEPT THAT CURB RAMP TYPE 6 SHALL BE A MINIMUM OF 5 FEET.
 - FOR CURB RAMP TYPES 5 AND 6, IF A GRASS BUFFER DOES NOT EXIST, SLOPE CURB TO EQUAL SLOPE OF ADJACENT CURB RAMP.
 - SIDEWALK AND CURB RAMP WITHIN AREA ENCLOSED BY HEAVY LINES TO BE PAID FOR AS CONCRETE SIDEWALK OF THE APPROPRIATE ADJACENT THICKNESS.
 - CURB AND HEADER WITHIN AREA ENCLOSED BY HEAVY LINES TO BE PAID FOR AS VERTICAL CURB OR SLOPING CURB OF THE APPROPRIATE ADJACENT SIZE AND KIND.
 - WHERE THE DISTANCE FROM THE GUTTER LINE TO THE OUTSIDE EDGE OF SIDEWALK IS 6 FEET OR LESS, CURB RAMP TYPE 7 SHOULD BE USED, INSTEAD OF CURB RAMP TYPE 1 THROUGH 4.
 - THE PUBLIC SIDEWALK CURB RAMP DELINEATION (SHADED AREA) SHALL BE SAFETY RED IN COLOR.
 - CROSSWALKS AND STOP LINES MAY BE MARKED OR UNMARKED, SEE PLANS.
 - PREFERRED AND ALTERNATE TREATMENTS SHOULD NOT BE INTERMIXED WITHIN THE SAME INTERSECTION.
 - DIMENSIONS SHOWN IN TABLES ARE FOR 3 INCH TO 9 INCH CURB HEIGHTS. WHERE THE CURB HEIGHTS ARE OTHER THAN WHAT IS PROVIDED IN THE TABLES, THE DIMENSIONS OF THE RAMPS WILL HAVE TO BE CALCULATED BASED ON CROSS SLOPES SHOWN.

PUBLIC SIDEWALK AND CURB RAMPS

N.T.S.

HMA = HOT ASPHALT MIX CD-607-1

NEW JERSEY DEPARTMENT OF TRANSPORTATION

CONSTRUCTION DETAILS

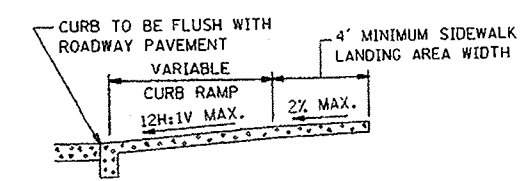

SECTION THROUGH CURB RAMPS 1 THROUGH 6

CD-607-1.3

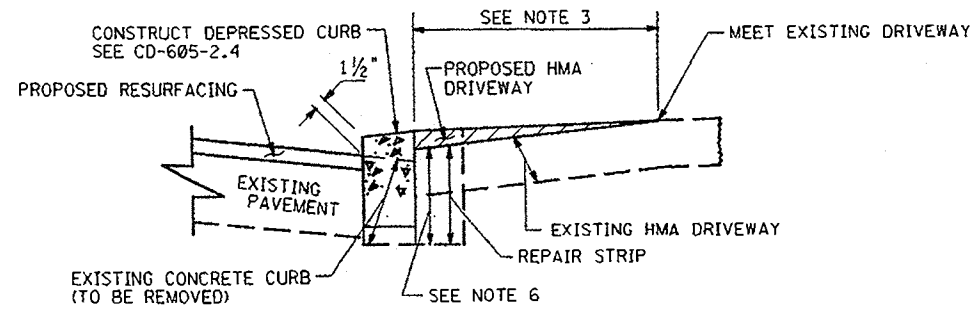

TYPE A

RESURFACING OF EXISTING HMA DRIVEWAY (WITH DEPRESSED CURB)

CD-607-2.1

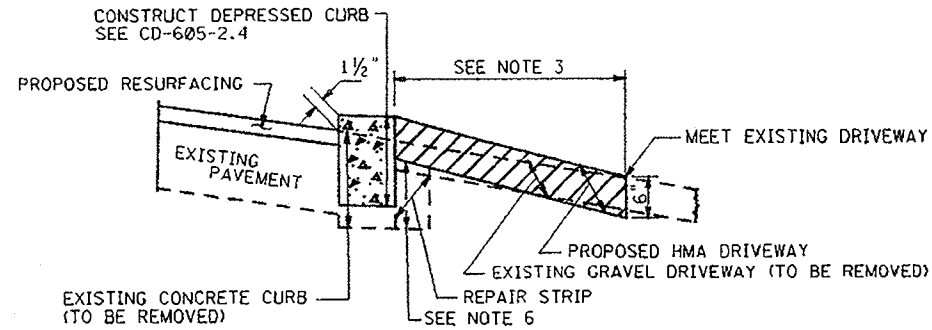

TYPE C

CONSTRUCTION OF HMA DRIVEWAY OR CONVERSION OF EXISTING GRAVEL DRIVEWAY (WITH DEPRESSED CURB)

CD-607-2.4

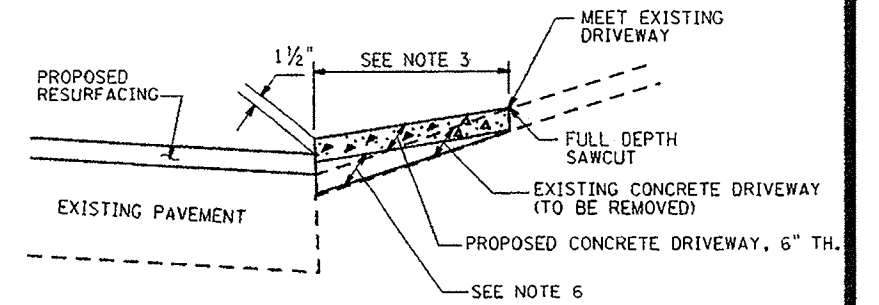

TYPE F

RECONSTRUCTION OF CONCRETE DRIVEWAY (WITHOUT DEPRESSED CURB)

CD-607-2.7

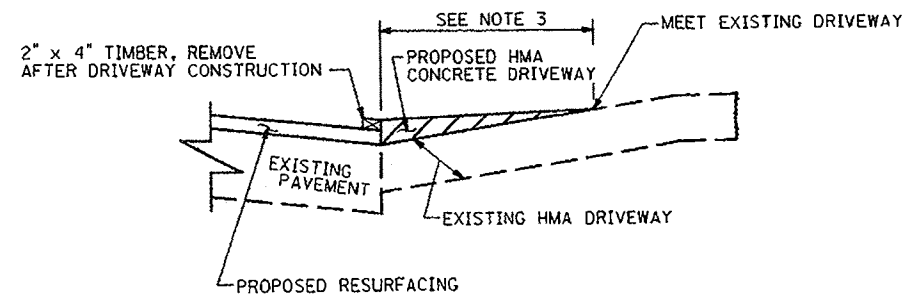

TYPE B

RESURFACING OF EXISTING HMA DRIVEWAY (WITHOUT DEPRESSED CURB)

CD-607-2.2

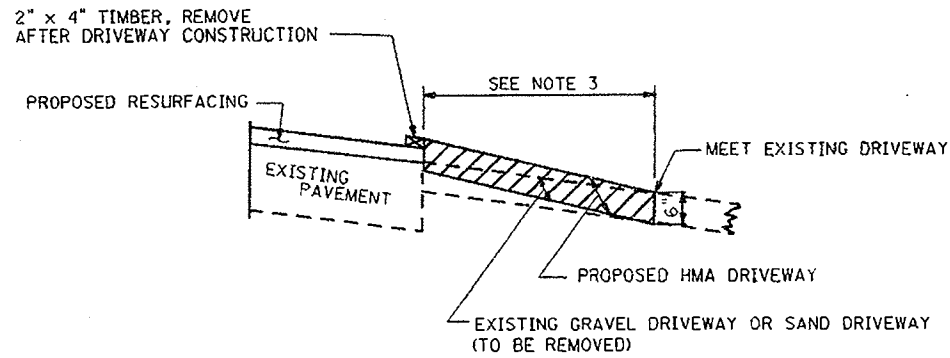

TYPE D

CONSTRUCTION OF HMA DRIVEWAY OR CONVERSION OF EXISTING GRAVEL DRIVEWAY (WITHOUT DEPRESSED CURB)

CD-607-2.5

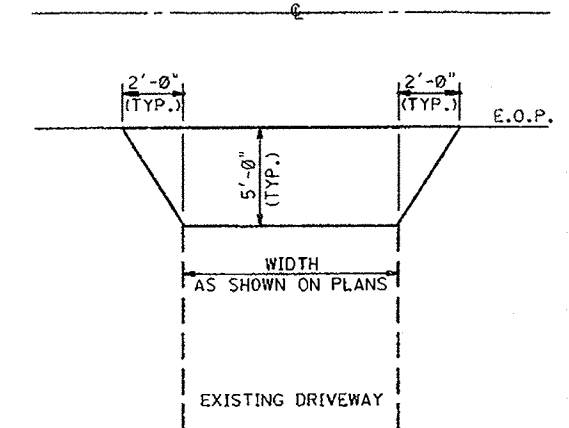

TYPICAL DRIVEWAY TREATMENT

PLAN VIEW

CD-607-2.8

GENERAL NOTES

1. ALL MATERIAL, REPAIR STRIPS AND EXCAVATION FOR DRIVEWAY CONSTRUCTION TO BE INCLUDED IN THE BID PRICE FOR HMA DRIVEWAY, CONCRETE DRIVEWAY OR CONCRETE CURB.
2. HMA DRIVEWAY SURFACE COURSE, TOP LAYER AND BOTTOM LAYER SHALL BE MIX I-5.
3. LENGTH OF DRIVEWAY WORK SHALL BE 5 FEET UNLESS OTHERWISE SHOWN ON PLANS OR AS DIRECTED.
4. MAINTAIN EXISTING DIRECTION OF FLOW ON DRIVEWAY.
5. DENSE GRADED AGGREGATE BASE COURSE SHALL BE USED TO PROVIDE TEMPORARY ACCESS DURING DRIVEWAY CONSTRUCTION.
6. GRANULAR MATERIAL FROM THE PROJECT OR SOIL AGGREGATE AS DIRECTED.
7. NO BASE COURSE IS REQUIRED FOR DRIVEWAY.

CD-607-2.3

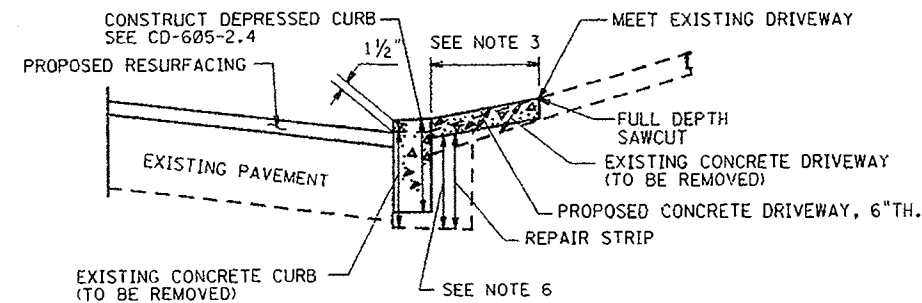

TYPE E

RECONSTRUCTION OF CONCRETE DRIVEWAY (WITH DEPRESSED CURB)

CD-607-2.6

DRIVEWAYS

N.T.S.

HMA = HOT ASPHALT MIX

CD-607-2

NEW JERSEY DEPARTMENT OF TRANSPORTATION

CONSTRUCTION DETAILS

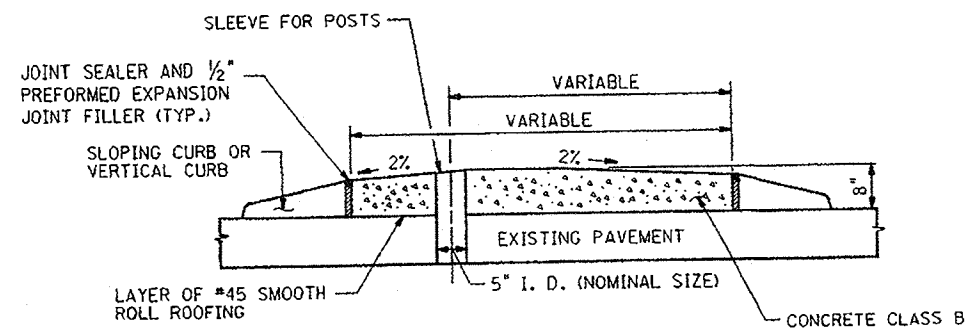

CONCRETE / WHITE CONCRETE ISLAND ON EXISTING PAVEMENT

CD-608-1.1

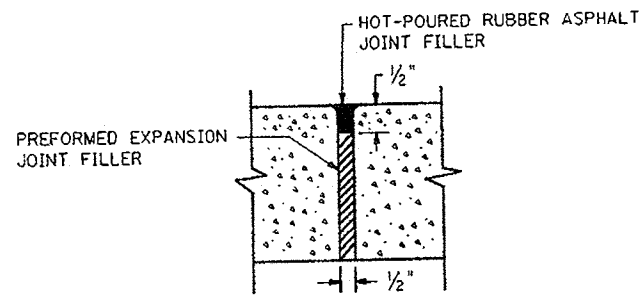

LONGITUDINAL & TRANSVERSE JOINT TREATMENT FOR CONCRETE ISLAND

CD-608-1.2

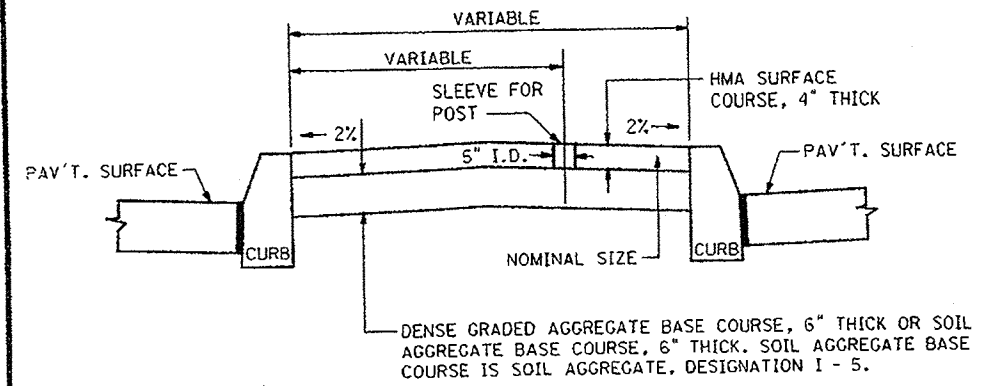

HMA ISLAND, 10" THICK

CD-608-1.3

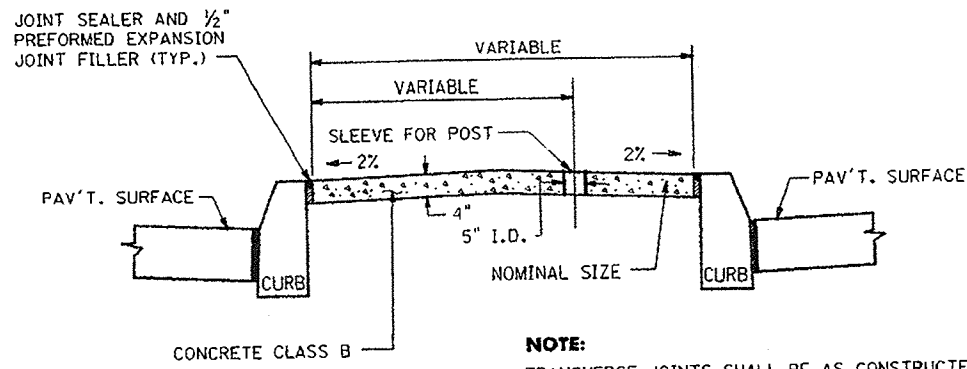

CONCRETE / WHITE CONCRETE ISLAND, 4" THICK

CD-608-1.4

NOTE:
TRANSVERSE JOINTS SHALL BE AS CONSTRUCTED FOR CONCRETE VERTICAL CURB.

CONCRETE AND HMA ISLANDS

N.T.S.

HMA = HOT ASPHALT MIX

CD-608-1

NEW JERSEY DEPARTMENT OF TRANSPORTATION

CONSTRUCTION DETAILS

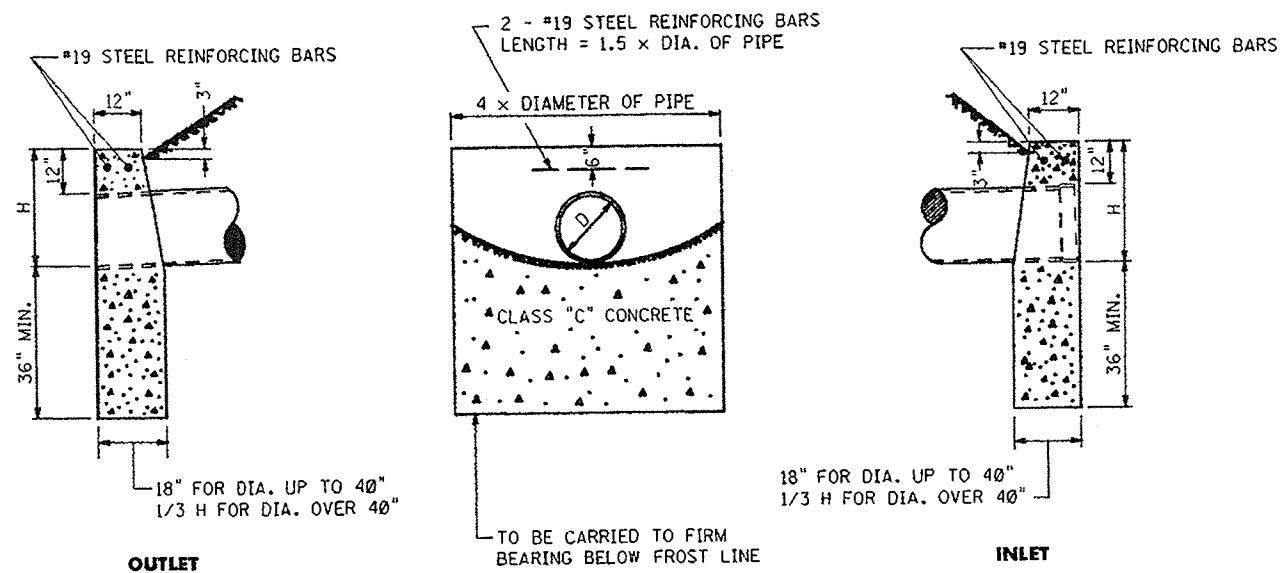

CONCRETE HEADWALLS

HEADWALL QUANTITY IN CUBIC YARDS

PIPE DIA.	CORR. STEEL PIPE	REINF. CONC. PIPE
12"	1.0	1.1
15"	1.3	1.4
18"	1.7	1.7
21"	2.0	2.1
24"	2.3	2.5
27"	2.7	2.8
30"	3.1	3.3
36"	3.9	4.2
42"	4.8	5.8
48"	6.3	7.6
54"	8.1	9.7
60"	10.1	12.1
66"	12.3	14.9
72"	14.5	18.0

GENERAL NOTES:

1. THE RUBBING OF HEADWALLS TO REMOVE FORM MARKS AS REQUIRED IN THE NJDOT SPECIFICATIONS FOR CONCRETE STRUCTURES, WILL NOT BE REQUIRED FOR HEADWALLS AT THE BOTTOM OF EMBANKMENT IN RURAL AREAS.
2. ALL EDGES TO BE CHAMFERED 1 INCH.
3. FOR ARCH PIPE USE LENGTH OF HEADWALL AS $3H + \text{SPAN}$.
4. FOR MORE THAN ONE PIPE, SET THE PIPE A MINIMUM OF ONE FOOT APART (OUTSIDE BARREL TO OUTSIDE BARREL); THE ENDS OF THE HEADWALL SHALL BE SET $2 \times \text{DIAMETER}$ OFF THE CENTERLINE OF THE CONTROLLING PIPE.

CD-610-1.1

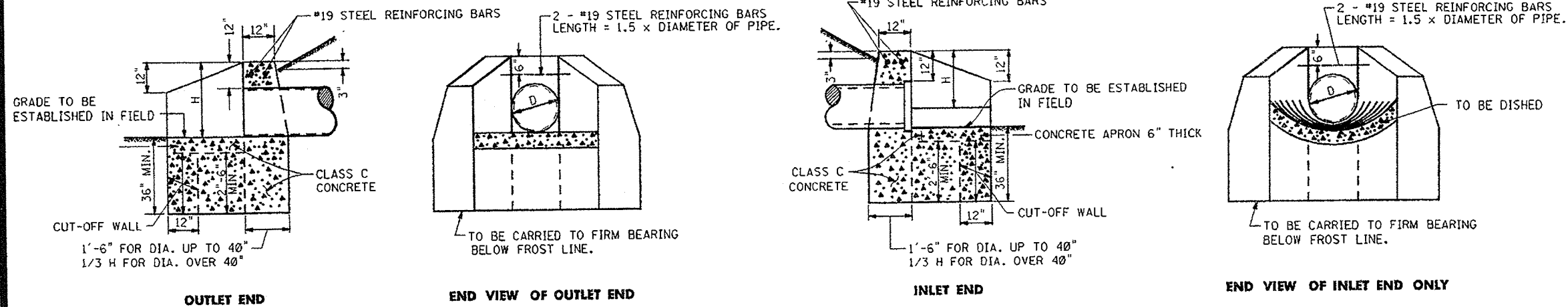

VOLUME OF CONCRETE IN HEADWALLS AND APRONS IN CUBIC YARDS

PIPE DIA.	CORR. STEEL PIPE	REIN. CONC. PIPE	APRONS
12"	1.6	1.7	0.4
15"	2.0	2.1	0.5
18"	2.4	2.5	0.6
21"	2.8	3.0	0.8
24"	3.3	3.4	0.9
27"	3.7	4.0	1.1
30"	4.2	4.5	1.2
36"	5.3	5.6	1.5
42"	7.2	7.9	1.9
48"	9.4	10.4	2.3
54"	12.0	13.3	2.7
60"	15.0	16.6	3.2
66"	18.5	20.5	3.7
72"	22.4	24.8	4.2

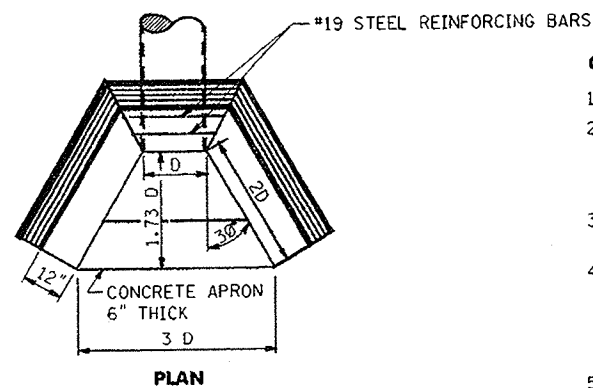

CONCRETE HEADWALLS AND APRONS

GENERAL NOTES:

1. ALL EDGES TO BE CHAMFERED 1 INCH.
2. THE RUBBING OF HEADWALLS TO REMOVE FORM MARKS AS REQUIRED IN THE NJDOT SPECIFICATIONS FOR CONCRETE STRUCTURES, WILL NOT BE REQUIRED FOR HEADWALLS AT THE BOTTOM OF EMBANKMENTS IN RURAL AREAS.
3. FOR SLOPE DRAIN HEADWALLS, DIMENSIONS AND APRON GRADES SHALL BE SET BY ENGINEER.
4. FOR MORE THAN ONE PIPE, SET THE PIPES A MINIMUM OF ONE FOOT APART (OUTSIDE BARREL TO OUTSIDE BARREL); THERE SHALL BE 12 INCHES ABOVE THE TOP OF A PIPE IN A WINGWALL; THE TERMINUS OF THE WINGWALL SHALL BE $2 \times \text{DIAMETER}$ FROM THE CENTERLINE OF THE PIPE IN A WINGWALL.
5. THE TERMINUS FOR OUTLET AND INLET APRONS SHALL BE SET BY EXTENDING THE PIPE GRADE AHEAD AND BACK, RESPECTIVELY.
6. FOR ARCH PIPE, THE SPAN SHALL BE SUBSTITUTED FOR D.

CD-610-1.2

NOTES:

REINFORCING BARS ARE IN METRIC UNITS.

CONCRETE HEADWALLS AND APRONS

N.T.S.

CD-610-1

NEW JERSEY DEPARTMENT OF TRANSPORTATION

CONSTRUCTION DETAILS

STANDARD 3'-0" CONCRETE CULVERT

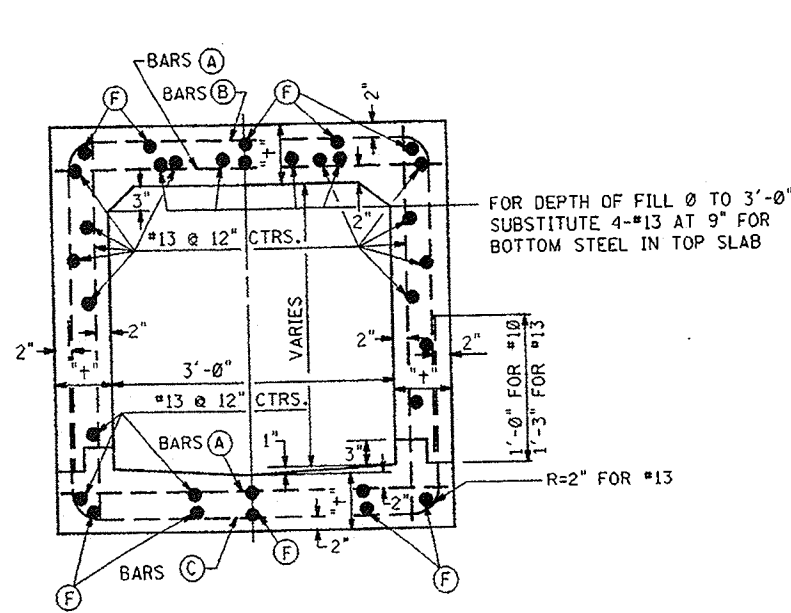

STANDARD 4'-0" CONCRETE CULVERT

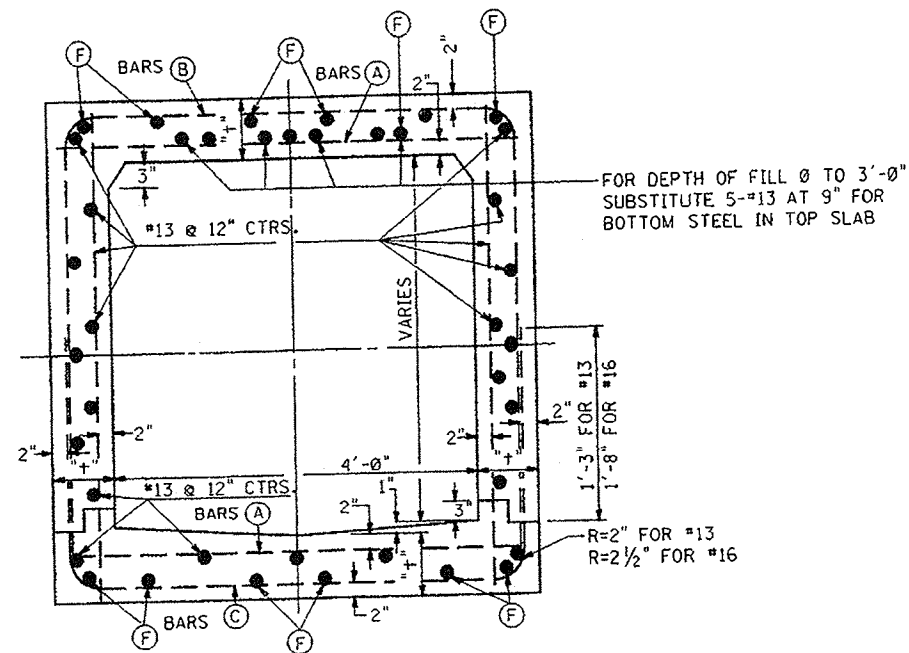

STANDARD 4'-11 1/2" CONCRETE CULVERT

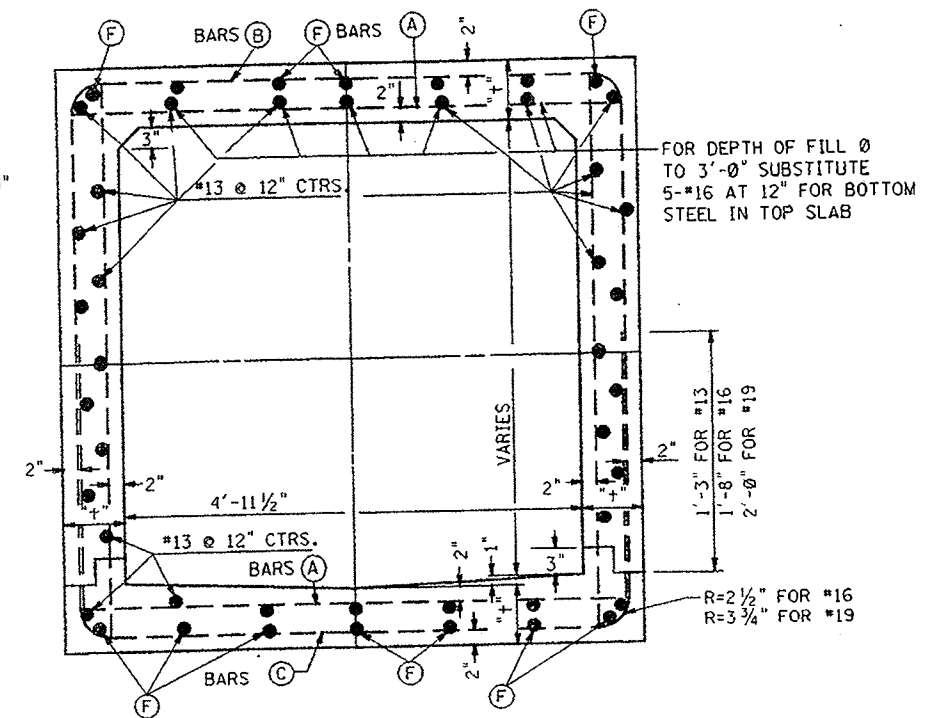

DEPTH OF FILL	BARS	SPAN 3 FT.		THICKNESS
		BARS	SPACING	
0	A	#13	5"	8"
	B&C	#13	12"	
3'-1"	A	#13	12"	8"
	B&C	#13	12"	
10'-1"	A	#13	9"	8"
	B&C	#13	10"	
15'-1"	A	#13	7"	8"
	B&C	#13	9"	
20'-1"	A	#13	6"	8"
	B&C	#13	7"	

DEPTH OF FILL	BARS	SPAN 4 FT.		THICKNESS
		BARS	SPACING	
0	A	#13	4"	8"
	B&C	#13	10"	
3'-1"	A	#13	9"	8"
	B&C	#13	12"	
10'-1"	A	#13	6"	8"
	B&C	#13	9"	
15'-1"	A	#16	7"	8"
	B&C	#16	10"	
20'-1"	A	#16	6"	9"
	B&C	#16	10"	

DEPTH OF FILL	BARS	SPAN 4'-11 1/2"		THICKNESS
		BARS	SPACING	
0	A	#16	5"	8"
	B&C	#16	12"	
3'-1"	A	#13	6"	8"
	B&C	#13	9"	
10'-1"	A	#16	7"	9"
	B&C	#16	12"	
15'-1"	A	#16	7"	10"
	B&C	#16	10"	
20'-1"	A	#16	5"	10"
	B&C	#16	8"	
25'-1"	A	#19	6"	11"
	B&C	#19	9"	

NOTES:

TOP AND BOTTOM LAYER OF LONGITUDINAL BARS (F) TO BE SAME SIZE AS BARS A, B & C AND SPACED 12" CTRS.

FOR BACKFILLING AND EMBANKMENT SEE NJDOT STANDARD SPECIFICATIONS.

REINFORCING BARS SHALL CONFORM TO AASHTO M31M.

NOTES:

REINFORCING BARS ARE IN METRIC UNITS.

VOLUME OF CONCRETE AND WEIGHT OF REINFORCEMENT PER LINEAR FOOT OF CULVERT

SIZE OF CULVERT OPENING IN FEET	3'-0" x 3'-0"					4'-0" x 3'-0"					4'-0" x 4'-0"					4'-11 1/2" x 3'-0"					4'-11 1/2" x 4'-0"					4'-11 1/2" x 5'-0"										
	3	10	15	20	25	3	10	15	20	25	3	10	15	20	25	3	10	15	20	25	3	10	15	20	25	3	10	15	20	25	3	10	15	20	25	40
MAX DEPTH OF FILL FT.	3	10	15	20	25	3	10	15	20	25	3	10	15	20	25	3	10	15	20	25	3	10	15	20	25	3	10	15	20	25	3	10	15	20	25	40
VOLUME OF CONCRETE CU. YD. PER FT.	0.37	0.37	0.37	0.37	0.37	0.42	0.42	0.42	0.42	0.48	0.47	0.47	0.47	0.47	0.47	0.54	0.47	0.47	0.54	0.61	0.61	0.52	0.52	0.60	0.67	0.67	0.57	0.57	0.65	0.73	0.73	0.82				
REINFORCEMENT LB. PER FT.	53	43	48	53	59	66	50	60	75	79	70	54	63	84	89	88	74	84	89	105	94	81	90	96	114	99	85	95	102	122	150					

NOTE:

FIRST DIMENSION OF CULVERT SIZE INDICATES THE SPAN. CULVERT TO BE CONSTRUCTED OF CLASS "A" CONCRETE.

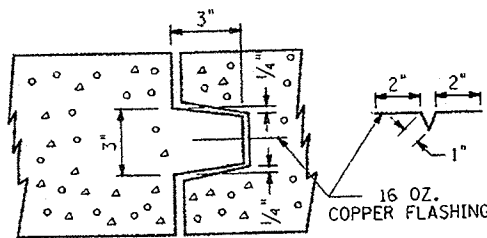

SECTION THRU KEY OF CONSTRUCTION JOINT
TO BE CONSTRUCTED IN TOP, WALLS AND BASE OF CULVERT NOT MORE THAN 35'-0" APART

CONSTRUCTION JOINT OF CULVERT

CD-610-2.2

CONCRETE CULVERTS

CD-610-2.1

CONCRETE CULVERTS
N.T.S.

CD-610-2

NEW JERSEY DEPARTMENT OF TRANSPORTATION

CONSTRUCTION DETAILS

41

129

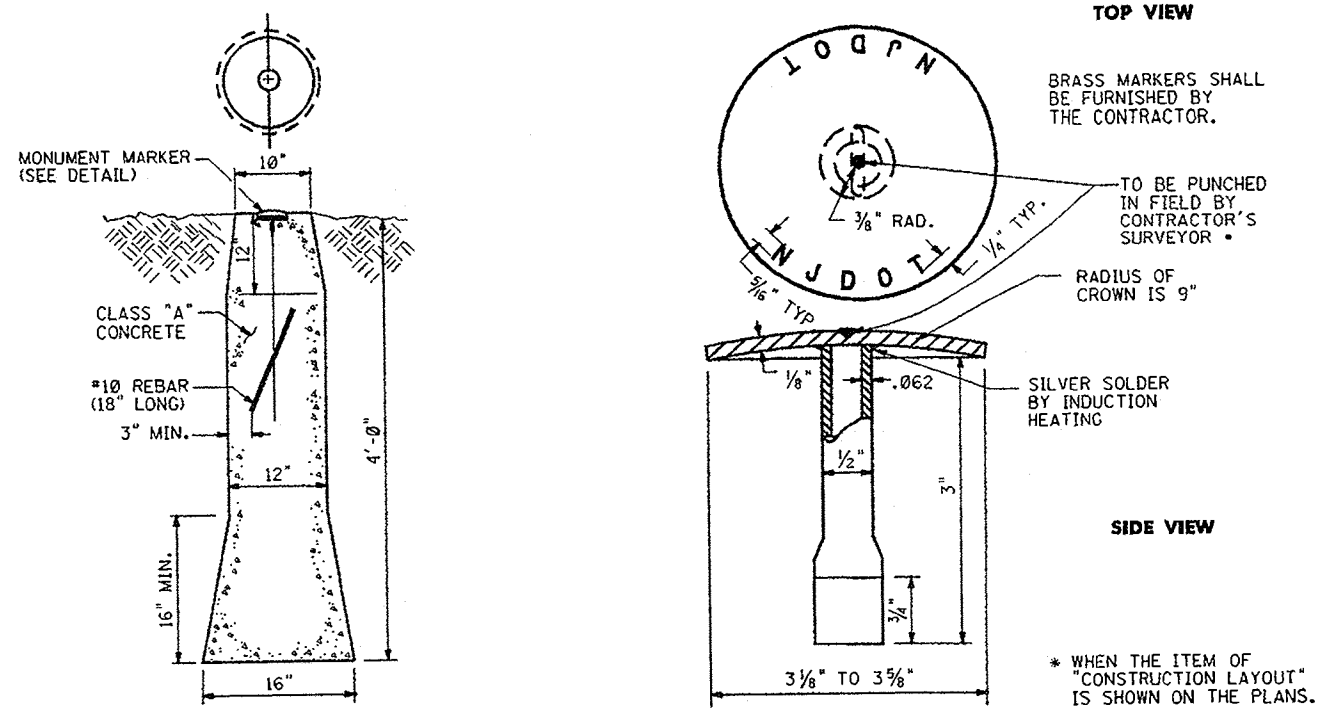

**MONUMENT MARKER
MONUMENTS TO BE SET FLUSH WITH GROUND**

GENERAL NOTES:

THE MONUMENTS SHALL BE CONSTRUCTED IN ACCORDANCE WITH NJDOT SPECIFICATIONS.
 THESE MONUMENTS ARE TO BE POURED IN PLACE AND THE MARKER PLUMBED INTO POSITION AND SET IN THE CONCRETE IN SUCH A MANNER THAT NO AIR WILL BE TRAPPED ON THE UNDERSIDE OF THE MARKER.
 #10 REBAR, 18" LONG, TO BE PLACED AT THE TIME OF CONCRETE POUR.
 THE MONUMENT MARKER SHALL BE MADE OF BRASS, CONFORMING TO ASTM B-19.

MONUMENTS

CD-611-1.1

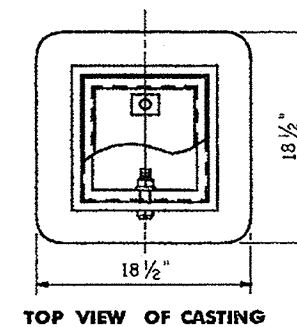
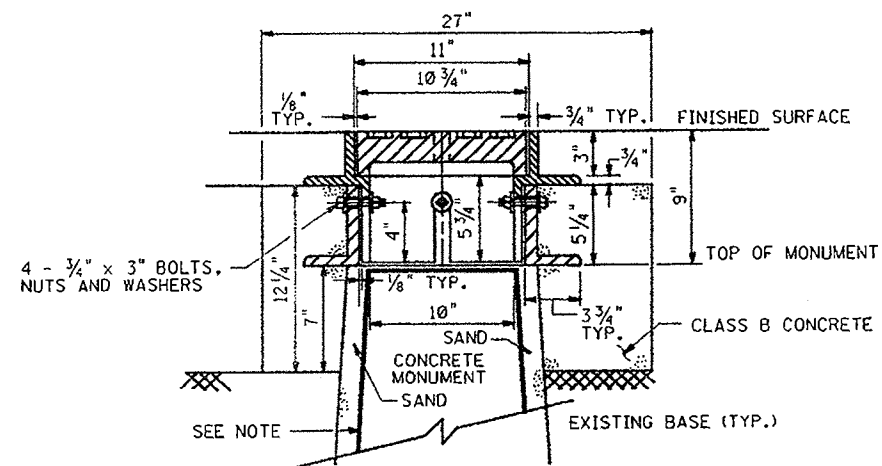

NOTE:
 A LAYER OF FELT OR NYLON OR TAR PAPER NEEDED BETWEEN SAND AND CONCRETE MONUMENT.

MONUMENT BOXES FOR NEW MONUMENTS

CD-611-1.2

NOTES:
 REINFORCING BARS ARE IN METRIC UNITS.

**MONUMENTS AND
MONUMENT BOXES**

N.T.S.

CD-611-1

NEW JERSEY DEPARTMENT OF TRANSPORTATION

CONSTRUCTION DETAILS

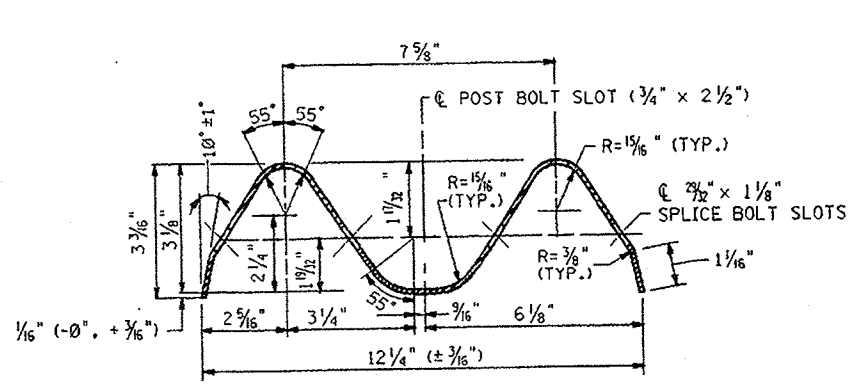

RAIL ELEMENT SHALL BE SUPPLIED IN LENGTHS OF 13'-6 1/2" OR 26'-1/2"

W-BEAM RAIL ELEMENT

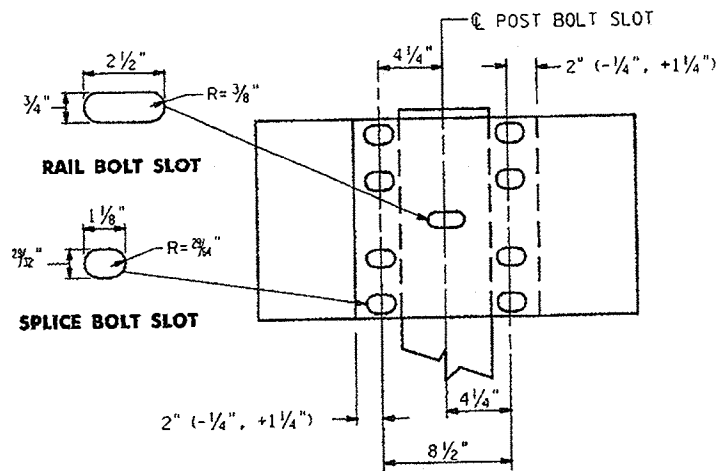

RAIL SPLICE

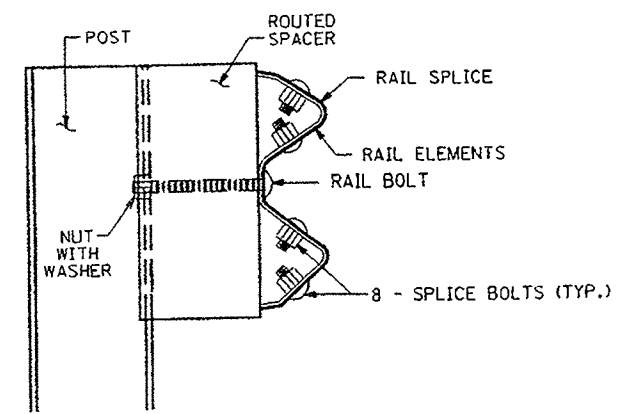

BEAM GUIDE RAIL POST ASSEMBLY

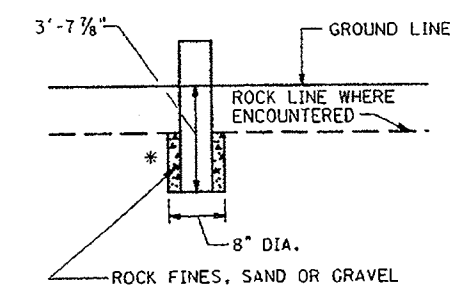

* ALTERNATE CONSTRUCTION METHOD: PLACE POST IN 8" DIA. HOLE AND BACKFILL WITH CLASS "C" CONCRETE

GUIDE RAIL POST INSTALLATION IN ROCK

CD-612-1.2

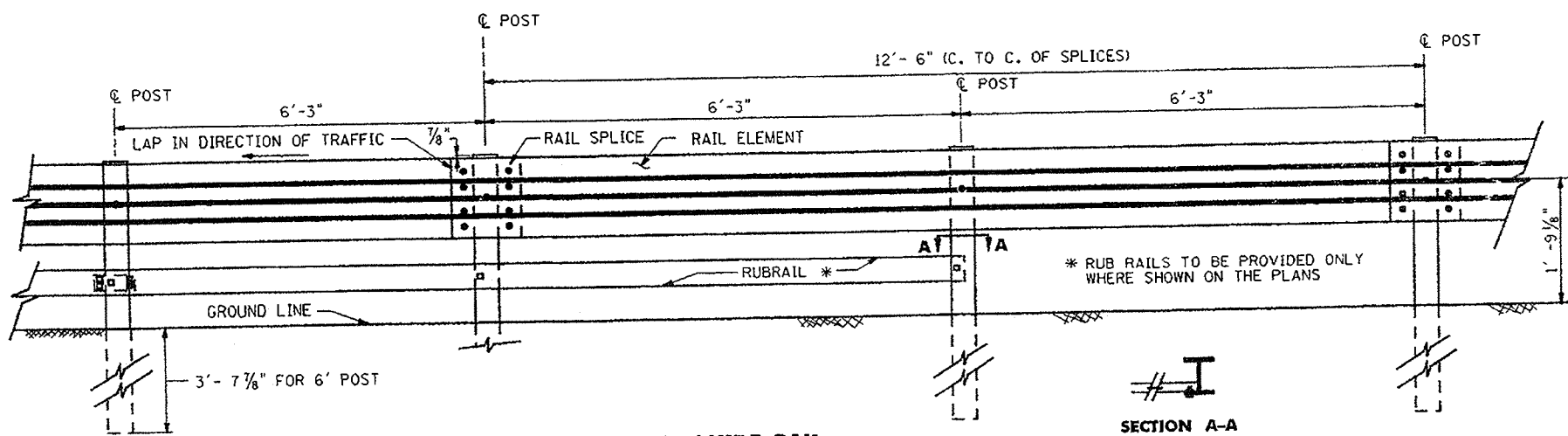

BEAM GUIDE RAIL

SECTION A-A

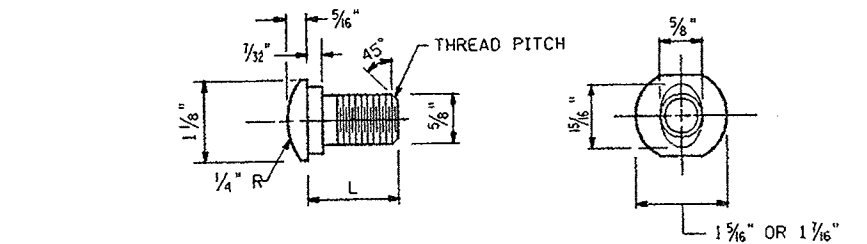

TYPE	L	MIN. THREAD LENGTH
SPLICE	1 1/4"	FULL LENGTH THREAD
RAIL	9 1/2"	1 3/4"

5/8" DIA. BUTTON HEAD BOLT

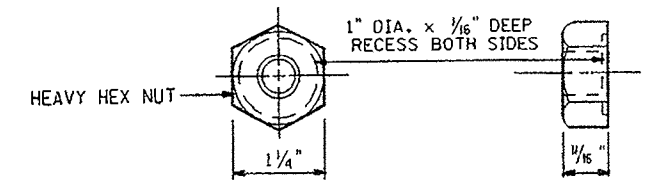

**5/8" DIA. RECESS NUT
SPLICE & RAIL NUT & BOLT**

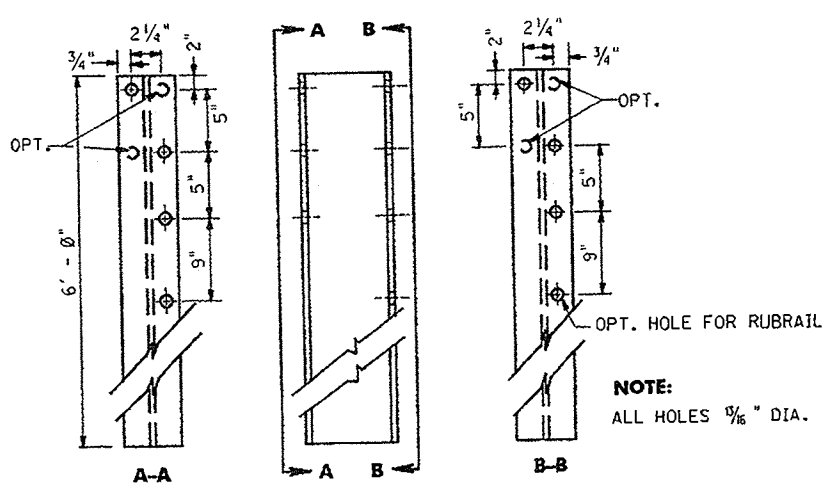

6" x 4" Steel I, 8.5# or 9# per FOOT

6' POST

NOTE:
DIMENSIONS SHOWN ARE FOR WOOD ROUTED SPACERS. DIMENSIONS FOR PROPRIETARY RECYCLED/SYNTHETIC SPACERS MAY VARY.

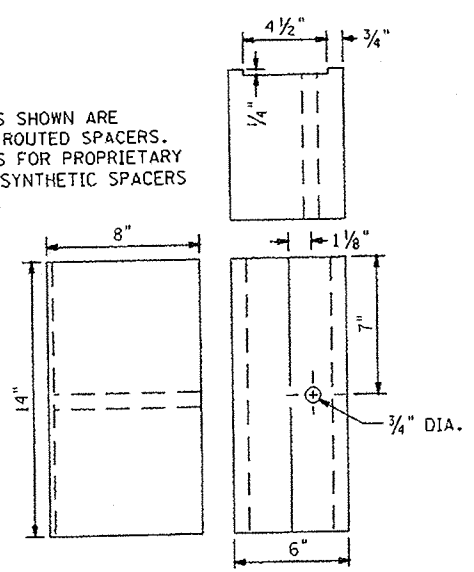

WOOD OR APPROVED RECYCLED/SYNTHETIC MATERIALS

14" ROUTED SPACER

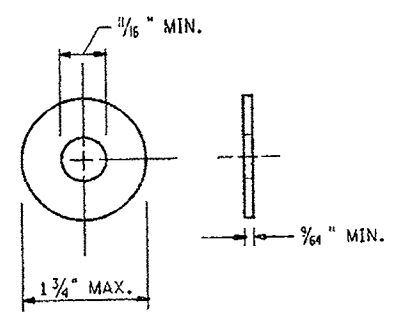

STEEL WASHER

- GENERAL NOTES:**
1. ALL DIMENSIONS ARE SUBJECT TO MANUFACTURING TOLERANCES.
 2. RAIL ELEMENTS SHALL BE FURNISHED SHOPCURVED, CONCAVE OR CONVEX, FOR RADII LESS THAN 150 FEET.
 3. THE STEEL FOR RAIL ELEMENTS AND BOLTS SHALL CONFORM TO NJDOT STANDARD SPECIFICATIONS AND ITS AMENDMENTS.

**BEAM GUIDE RAIL
N.T.S.**

CD-612-1

NEW JERSEY DEPARTMENT OF TRANSPORTATION

CONSTRUCTION DETAILS

CD-612-1.1

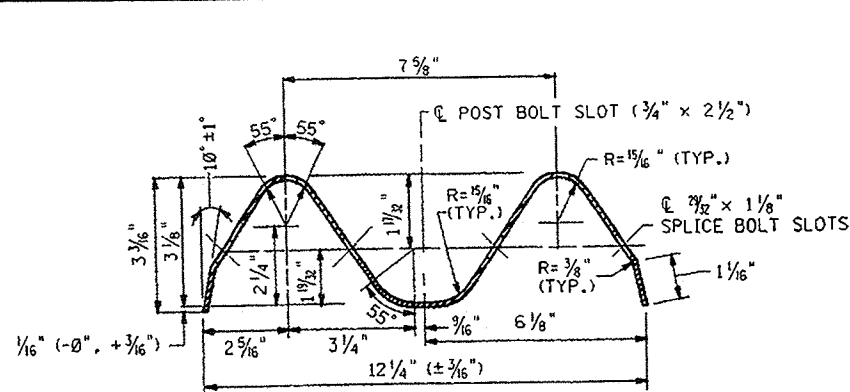

W-BEAM RAIL ELEMENT

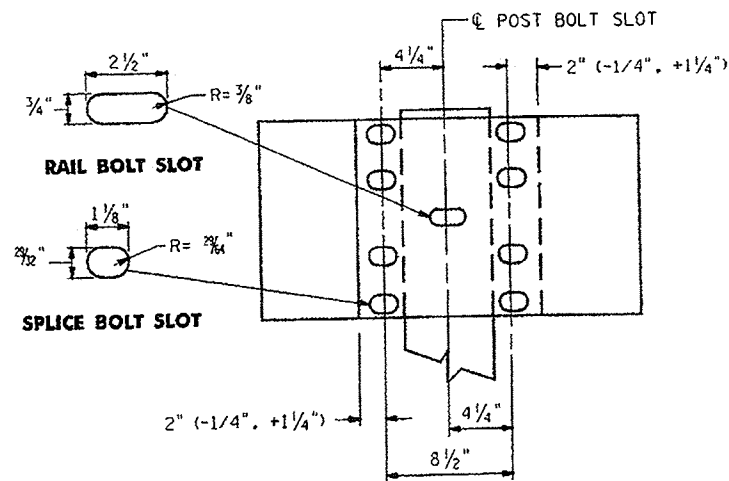

RAIL SPLICE

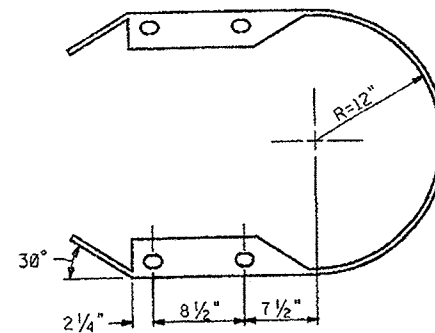

END SECTION (BUFFER)

- GENERAL NOTES:**
1. ALL DIMENSIONS ARE SUBJECT TO MANUFACTURING TOLERANCES.
 2. RAIL ELEMENTS SHALL BE FURNISHED SHOPCURVED, CONCAVE OR CONVEX, FOR RADII BETWEEN 20 FEET AND 150 FEET.
 3. THE STEEL FOR RAIL ELEMENTS AND BOLTS SHALL BE OF A QUALITY THAT WILL DEVELOP SPECIFICATION FOR BEAM AND TENSILE STRENGTHS.
 4. USE END SECTION (BUFFER) UNLESS THE CONSTRUCTION PLANS CALL FOR ANOTHER TYPE OF END TREATMENT.

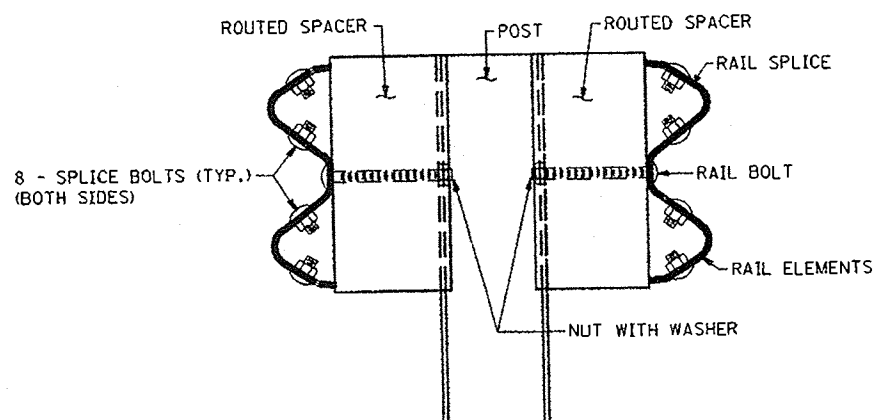

POST ASSEMBLY, DUAL-FACED

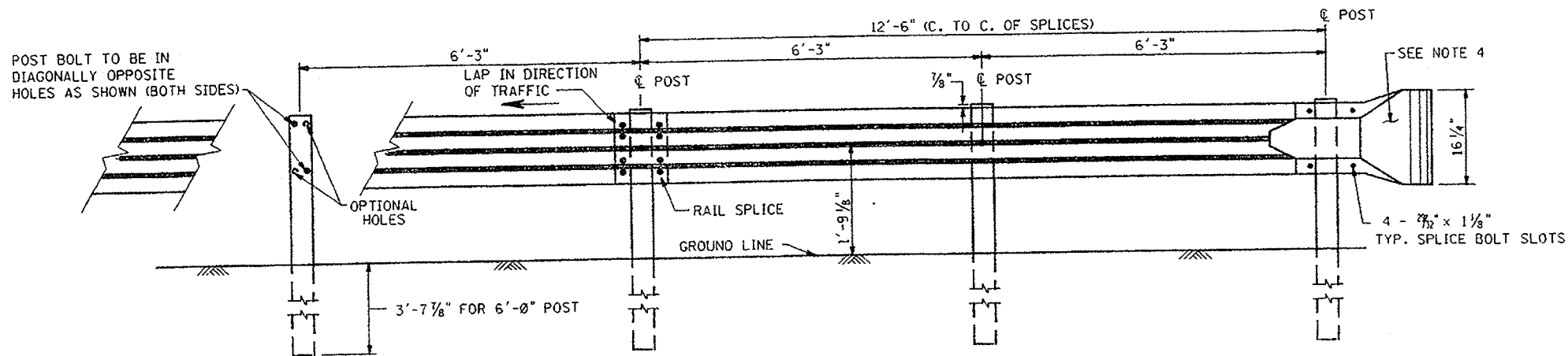

BEAM GUIDE RAIL, DUAL-FACED

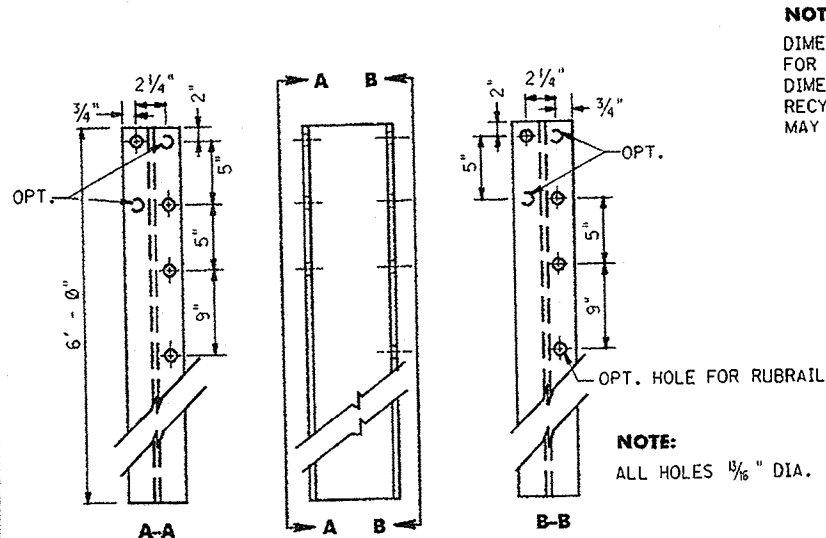

6" POST

6" x 4" STEEL I, 8.5# OR 9# PER FOOT

NOTE:
DIMENSIONS SHOWN ARE FOR WOOD ROUTED SPACERS. DIMENSIONS FOR PROPRIETARY RECYCLED/SYNTHETIC SPACERS MAY VARY.

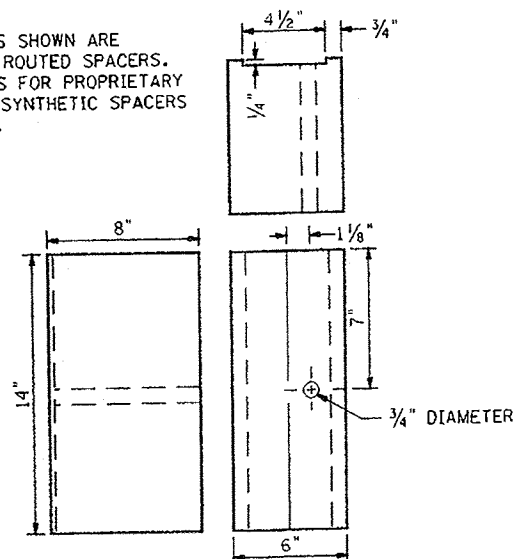

14" ROUTED SPACER

WOOD OR APPROVED RECYCLED/SYNTHETIC MATERIALS

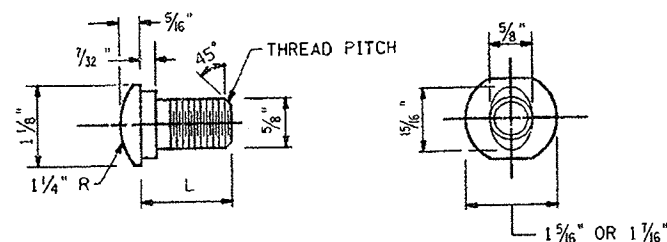

5/8" DIA. BUTTON HEAD BOLT

TYPE	L	MIN. THREAD LENGTH
SPLICE	1 1/4"	FULL LENGTH THREAD
RAIL	9 1/2"	1 3/4"

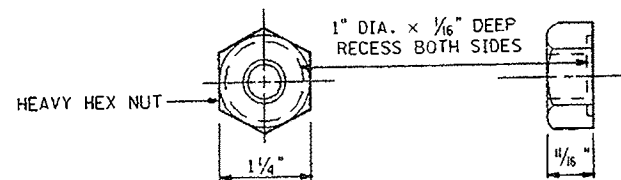

**5/8" DIA. RECESS NUT
SPLICE & RAIL NUT & BOLT**

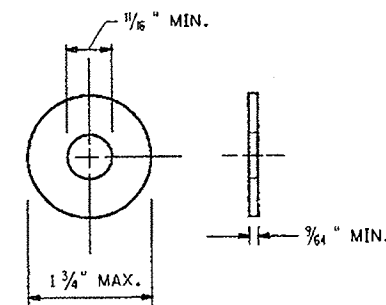

STEEL WASHER

BEAM GUIDE RAIL, DUAL-FACED

N.T.S.

CD-612-2

NEW JERSEY DEPARTMENT OF TRANSPORTATION

CONSTRUCTION DETAILS

CD-612-2.1

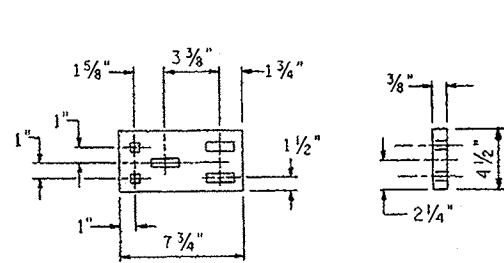

SPLICE PLATE

NOTE:
ALL RECTANGULAR SLOTS ARE 1/8" x 2"
ALL SQUARE HOLES ARE 1/8"

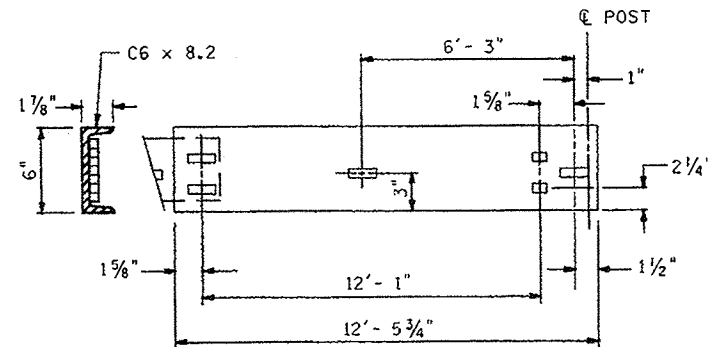

C6 x 8.2

RUB RAIL MAY BE SUPPLIED IN LENGTHS OF 12'-5 3/4" OR 24'-11 3/4"

NOTE:
USE EITHER C6 x 8.2 OR BENT PLATE FOR RUB RAIL

CD-612-3.1

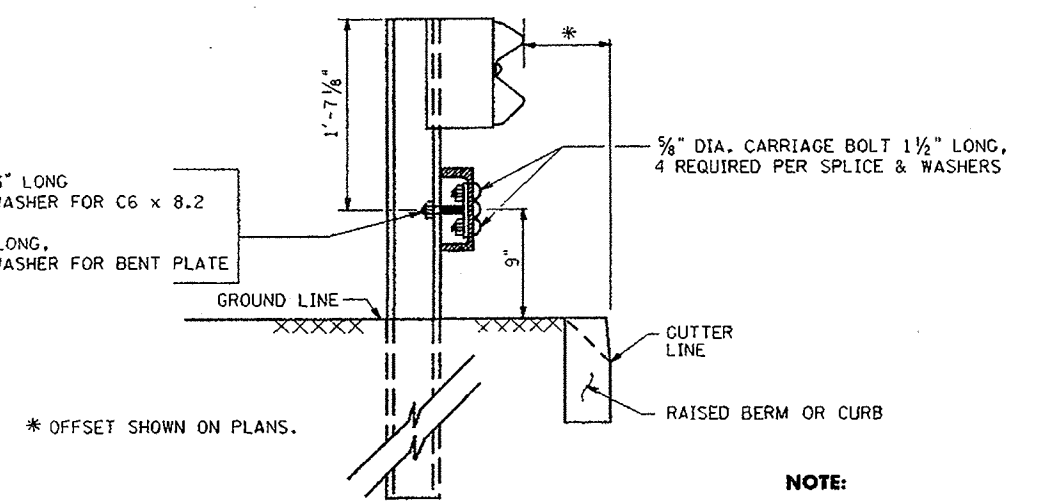

RUB RAIL SECTION

NOTE:
USE EITHER C6 x 8.2 OR BENT PLATE FOR RUB RAIL

CD-612-3.2

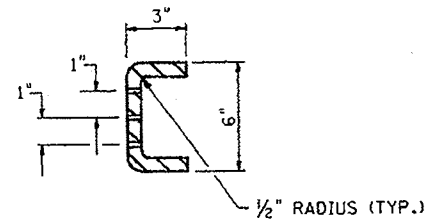

SECTION A-A

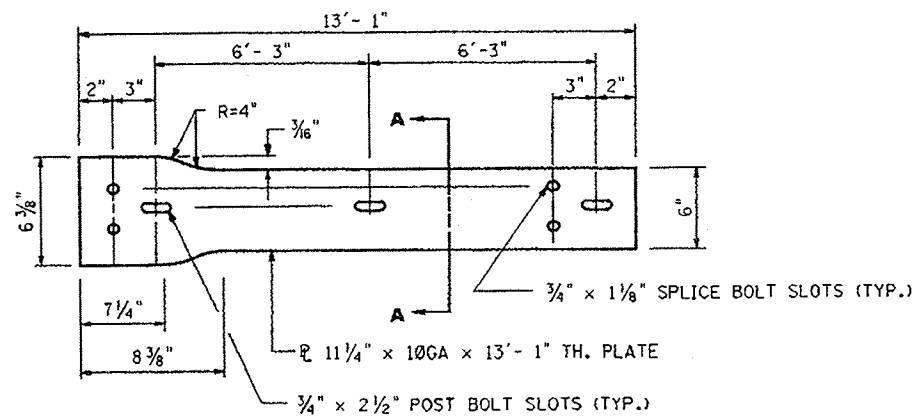

BENT PLATE

NOTE:
USE EITHER C6 x 8.2 OR BENT PLATE FOR RUB RAIL

CD-612-3.3

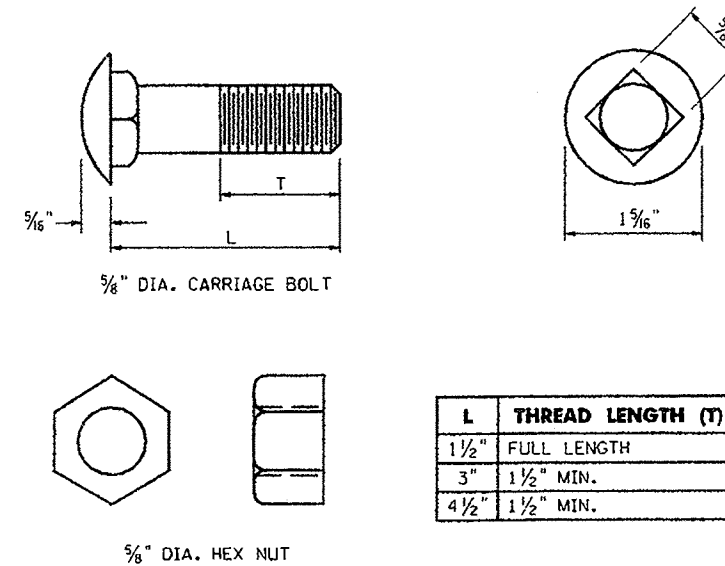

CARRIAGE BOLT DETAIL

CD-612-3.4

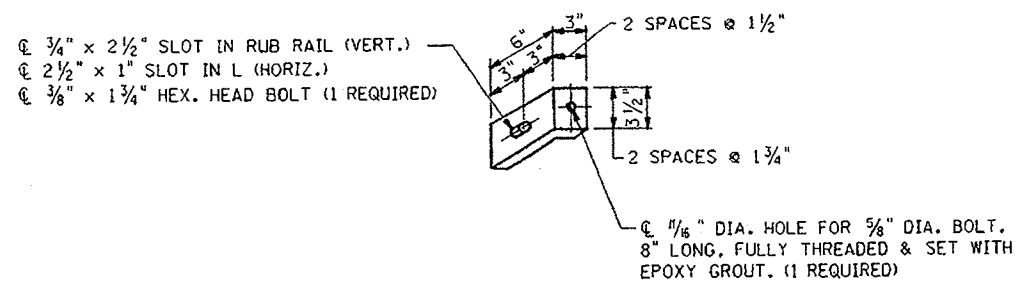

RUB RAIL ANGLE ATTACHMENT

SEE CD-612-9.4 FOR GENERAL NOTES

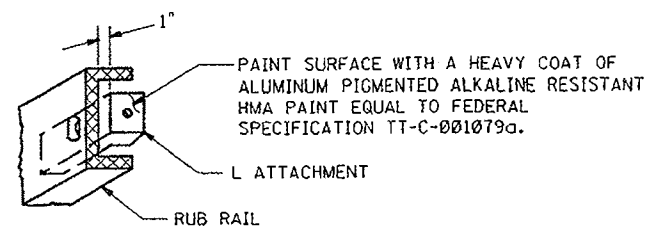

CD-612-3.5

RUB RAIL

N.T.S.

HMA = HOT ASPHALT MIX CD-612-3

NEW JERSEY DEPARTMENT OF TRANSPORTATION

CONSTRUCTION DETAILS

NOTE:

CABLE TO BE PARALLEL TO GUIDE RAIL FOR STRAIGHT RUNS OF RAIL. CABLE MAY HAVE ANGLE POINT AT ANCHOR PLATE IF RAIL IS CURVED.

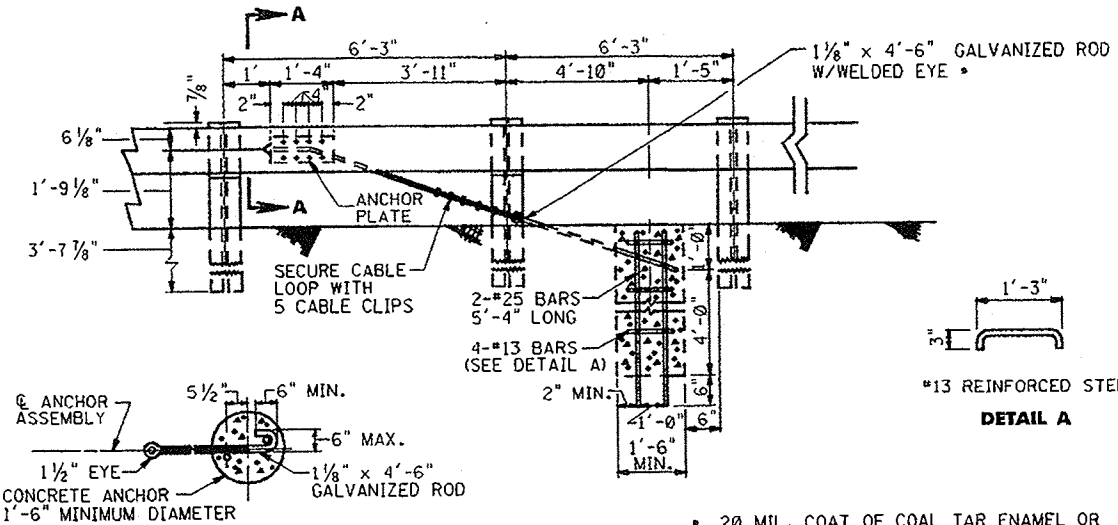
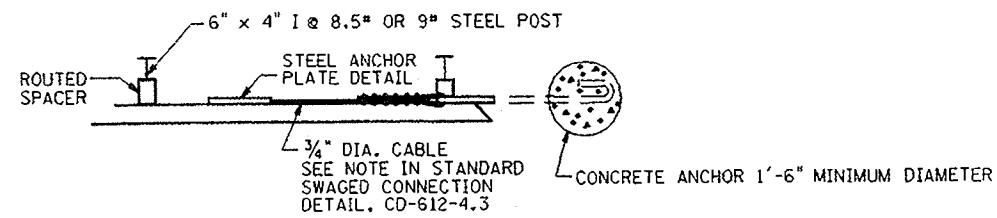

SINGLE GUIDE RAIL ANCHOR

BEAM GUIDE RAIL IN LINE ANCHORAGE

CD-612-4.1

NOTE:

PAYMENT FOR THE ITEM ANCHORAGE SHALL INCLUDE THE ANCHOR PLATE, CABLE ASSEMBLY & FOOTING.

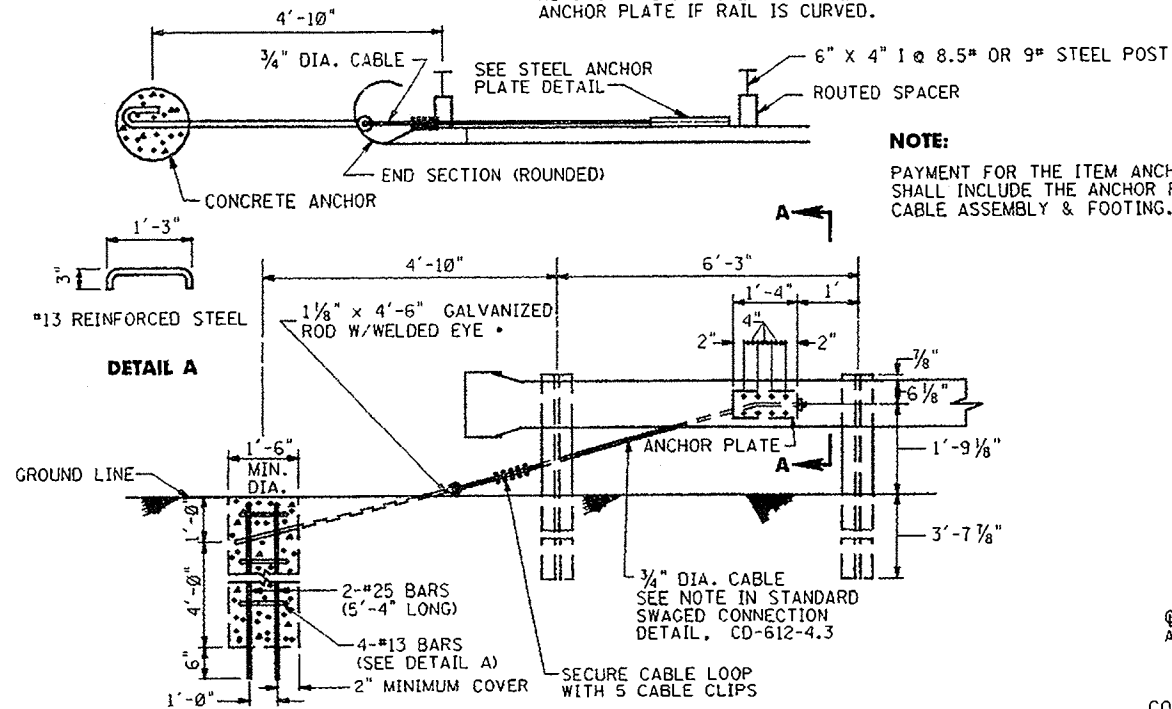

• 20 MIL. COAT OF COAL TAR ENAMEL OR EPOXY SHALL BE APPLIED TO GALVANIZED ROD BETWEEN EYE AND CONCRETE ANCHOR.

BEAM GUIDE RAIL END ANCHORAGE

NOTE:

CABLE TO BE PARALLEL TO GUIDE RAIL FOR STRAIGHT RUNS OF RAIL. CABLE MAY HAVE ANGLE POINT AT ANCHOR PLATE IF RAIL IS CURVED.

NOTE:

PAYMENT FOR THE ITEM ANCHORAGE SHALL INCLUDE THE ANCHOR PLATE, CABLE ASSEMBLY & FOOTING.

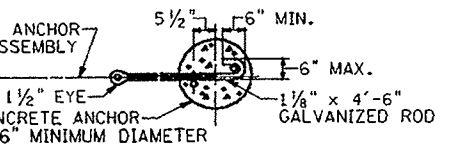
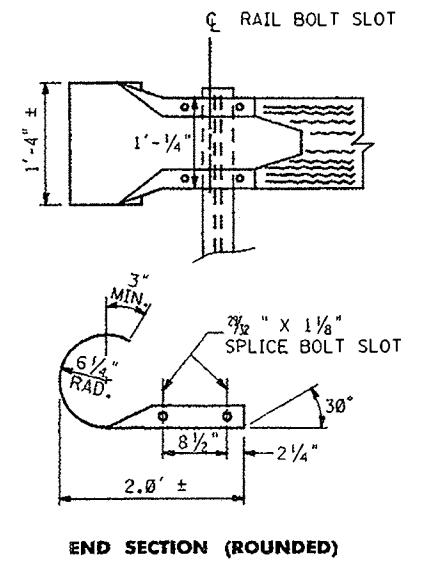

SINGLE GUIDE RAIL ANCHOR

CD-612-4.2

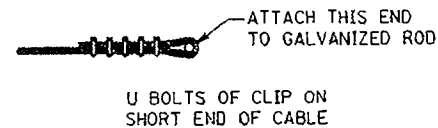

CABLE CLIP INSTALLATION

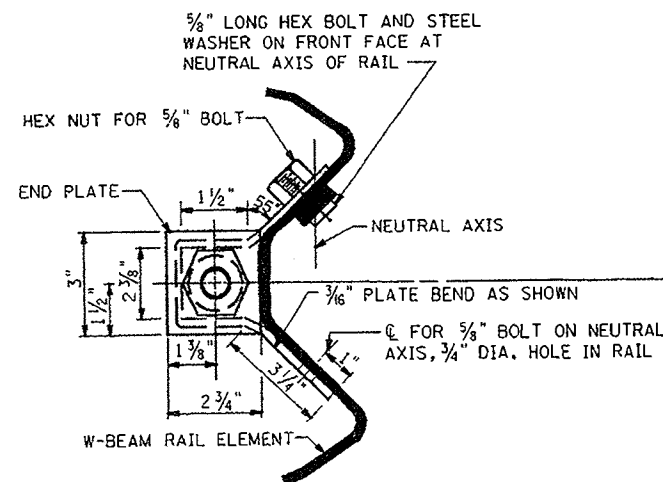

SECTION A-A (CD-612-4.1, CD-612-4.2)

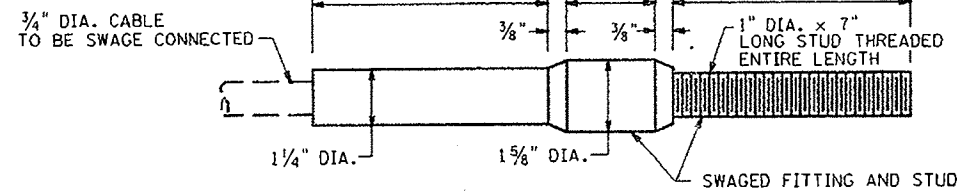

STANDARD SWAGED CONNECTION

NOTE:

OTHER ANCHOR CABLE ASSEMBLIES MAY BE USED. MINIMUM BREAKING STRENGTH OF ASSEMBLY SHALL BE 40,000 LBS.

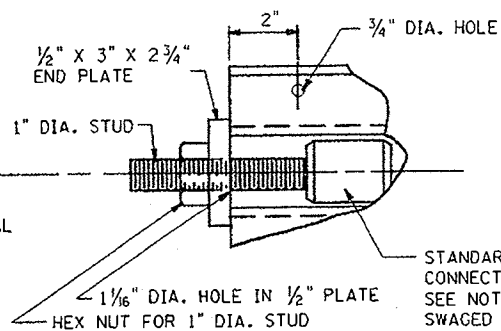

ANCHOR PLATE

STANDARD SWAGED CONNECTION CONNECTION FOR 3/4" CABLE. SEE NOTE IN STANDARD SWAGED CONNECTION DETAIL

CD-612-4.3

NOTES:

REINFORCING BARS ARE IN METRIC UNITS.

BEAM GUIDE RAIL ANCHORAGES
N.T.S.

CD-612-4

NEW JERSEY DEPARTMENT OF TRANSPORTATION

CONSTRUCTION DETAILS

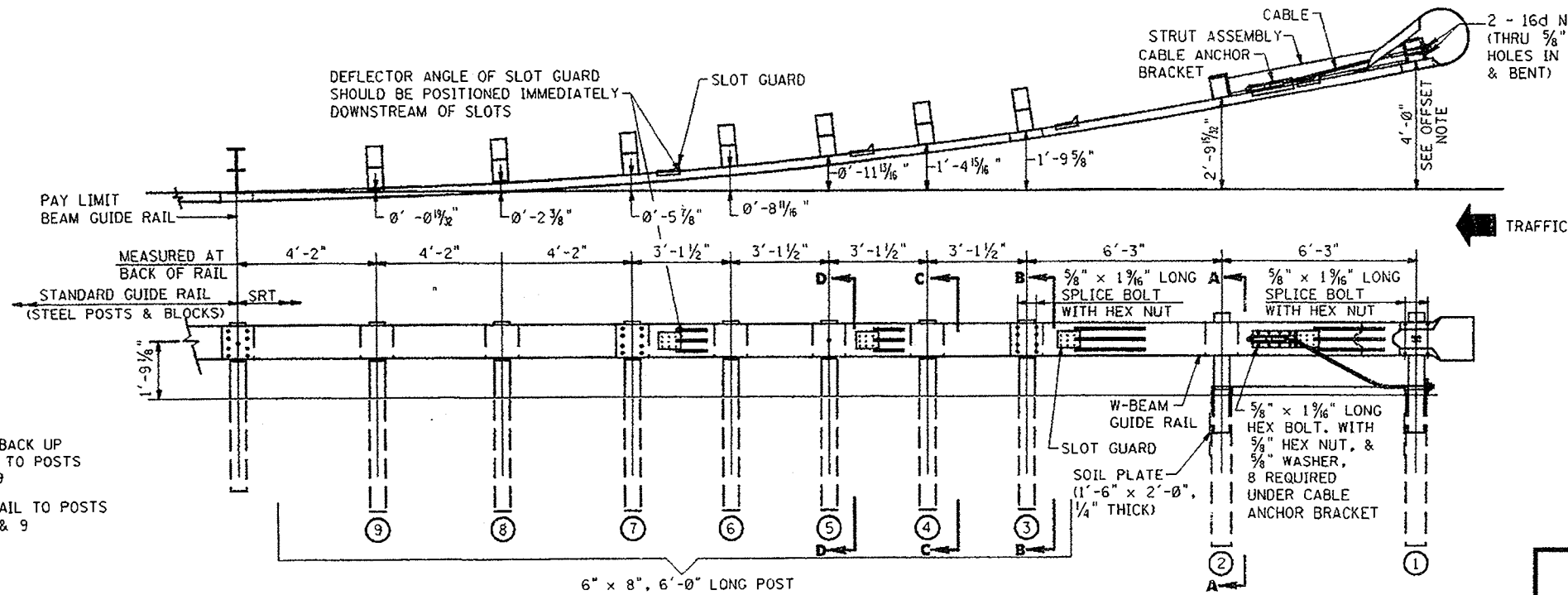

OFFSET NOTE:

THE POST OFFSET DIMENSIONS ARE GIVEN TO THE CENTER OF THE TRAFFIC FACE OF THE BLOCKOUTS, EXCEPT AT THE FIRST TWO POSTS, WHERE THE DIMENSIONS ARE TO THE CENTER OF THE TRAFFIC FACE OF THE POST. OFFSET POINTS ARE TO BE LOCATED BY CHORD MEASUREMENTS AT THE BACK OF THE RAIL EQUAL TO THE NOMINAL POST SPACINGS SHOWN. POSTS ARE TO BE SET APPROXIMATELY RADIAL TO THE RAILING AT EACH POST LOCATION.

NOTE:

SEE CD 612-8.6 FOR SLOPE TREATMENT AT SLOTTED GUIDE RAIL TERMINALS

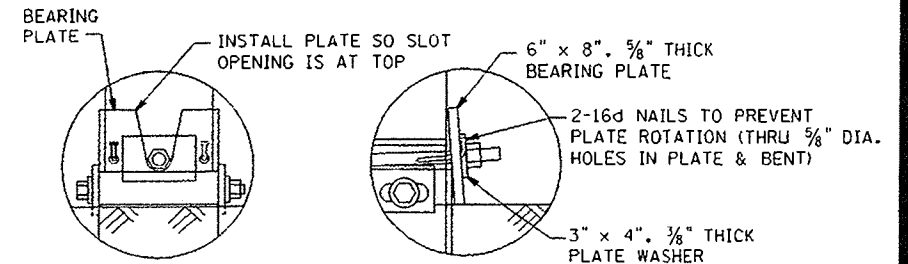

BEARING PLATE ORIENTATION

NOTES:
SLOTTED W-BEAM BACK UP PLATES ATTACHED TO POSTS 2, 4, 5, 6, 8 & 9
DO NOT ATTACH RAIL TO POSTS 2, 3, 4, 6, 7, 8 & 9

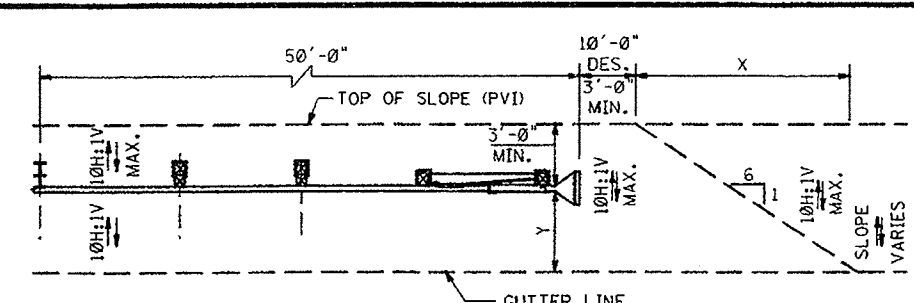

Y = OFFSET FROM GUTTER LINE	X	X + 10' (DES.)
* 1'-0"	24'-0"	34'-0"
4'-0"	42'-0"	52'-0"
7'-0"	60'-0"	70'-0"
10'-0"	78'-0"	88'-0"

GRADING TREATMENT AT EXTRUDER TERMINALS

*** NOTE:**

WHERE GUIDE RAIL IS INSTALLED FLUSH WITH THE GUTTER LINE, THE EXTRUDER TERMINAL SHALL BE CONSTRUCTED WITH A 50:1 STRAIGHT FLARE FOR ITS ENTIRE LENGTH SO THAT THE EXTRUDER HEAD DOES NOT PROTRUDE INTO THE ROADWAY.

CD-612-5.3

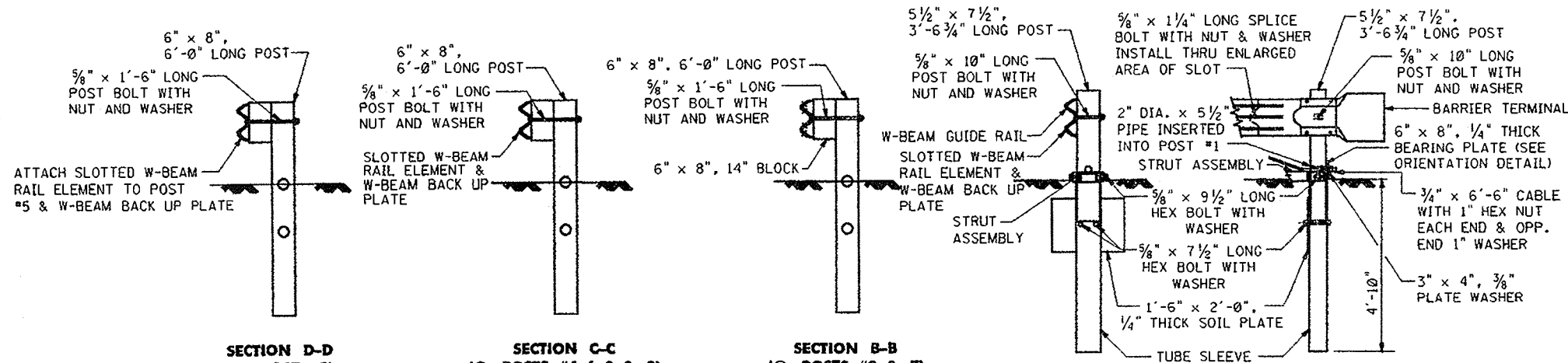

SLOTTED GUIDE RAIL TERMINALS

CD-612-5.1

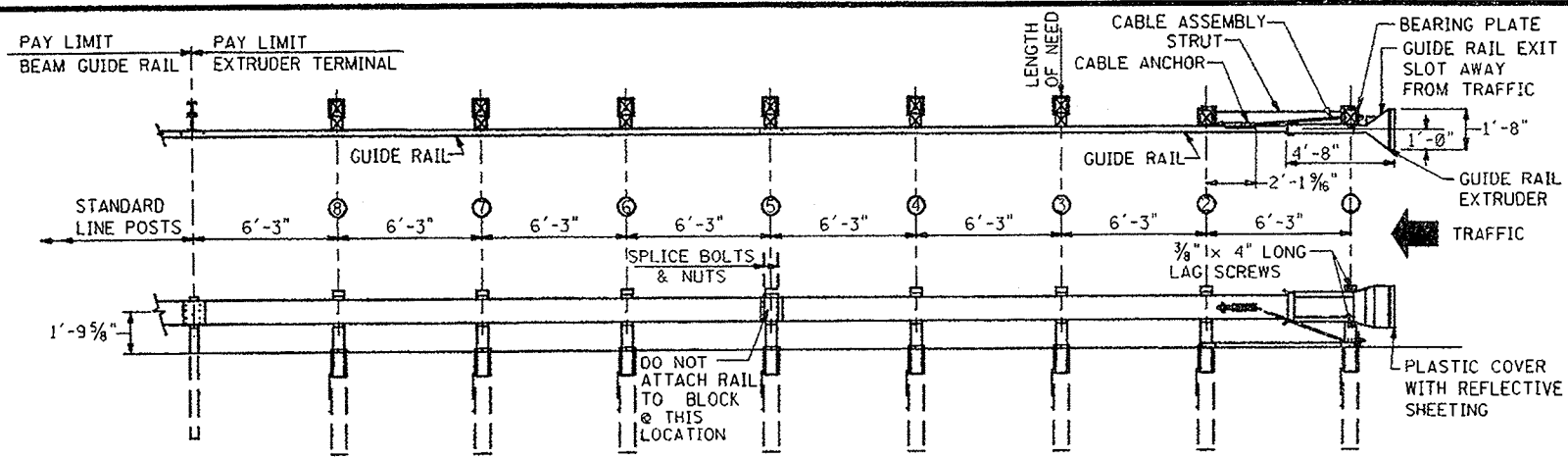

EXTRUDER TERMINALS

NOTE:
WOOD POSTS 1 THRU 8 SHALL BE CONSTRUCTED USING FOUNDATION TUBES.

SLOTTED GUIDE RAIL TERMINALS AND EXTRUDER TERMINALS

N.T.S.

CD-612-5

NEW JERSEY DEPARTMENT OF TRANSPORTATION

CONSTRUCTION DETAILS

CD-612-5.2

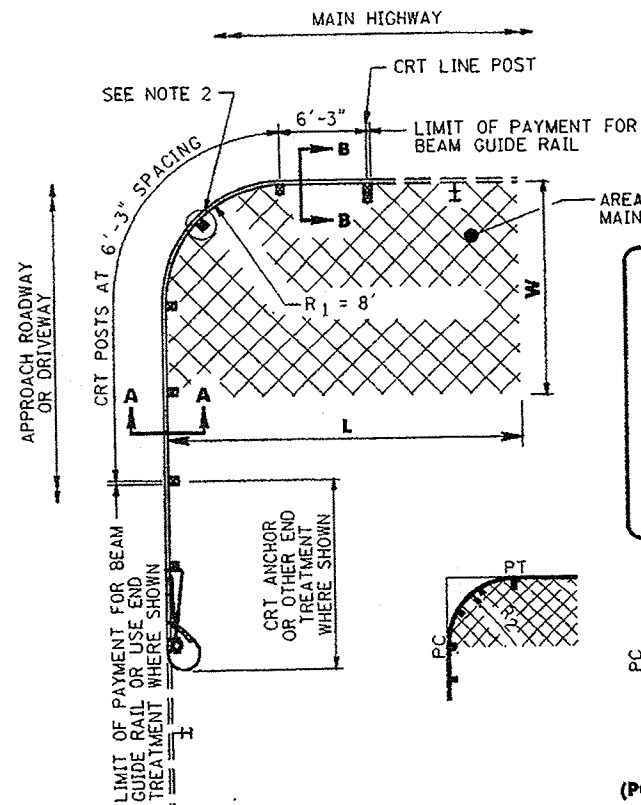

RADIUS	NO. OF CRT POSTS	REQUIRED AREA FREE OF FIXED OBJECTS
R_1 8'	5	L W 25' x 15'
R_2 16'	6	30' x 15'
R_3 24'	8	40' x 20'
R_4 36'	11	50' x 20'

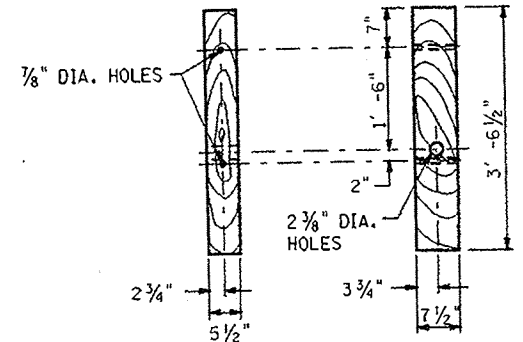
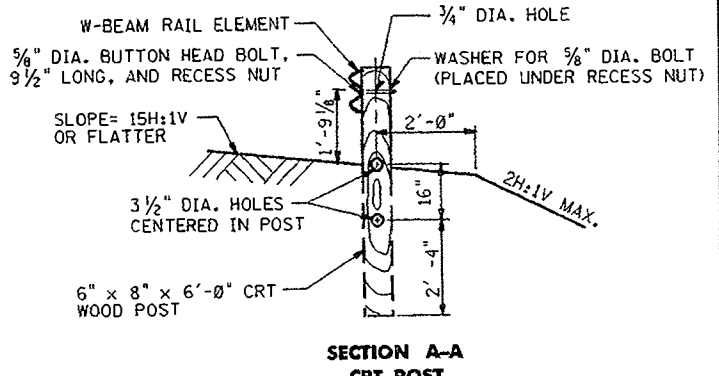
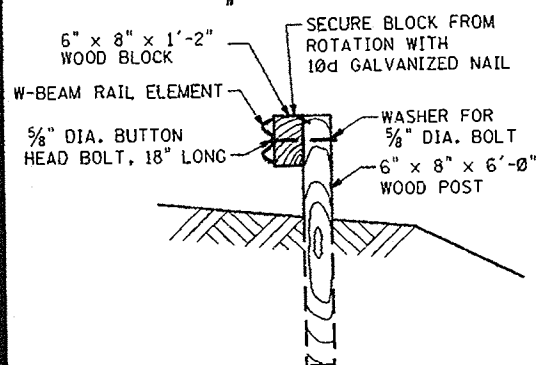
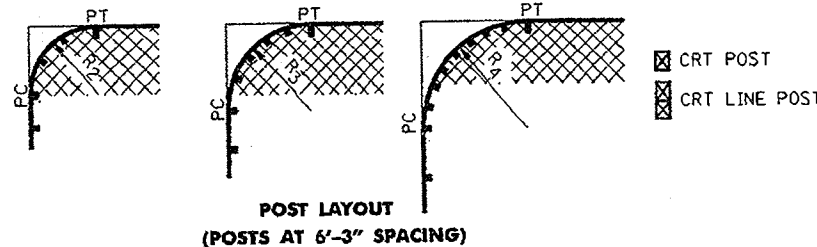

CONTROLLED RELEASE TERMINALS

CD-612-6.1

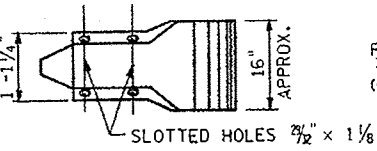
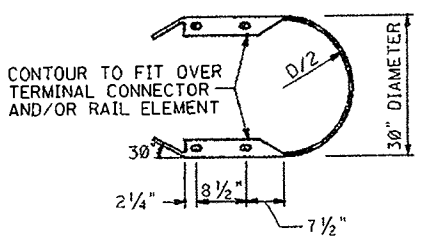
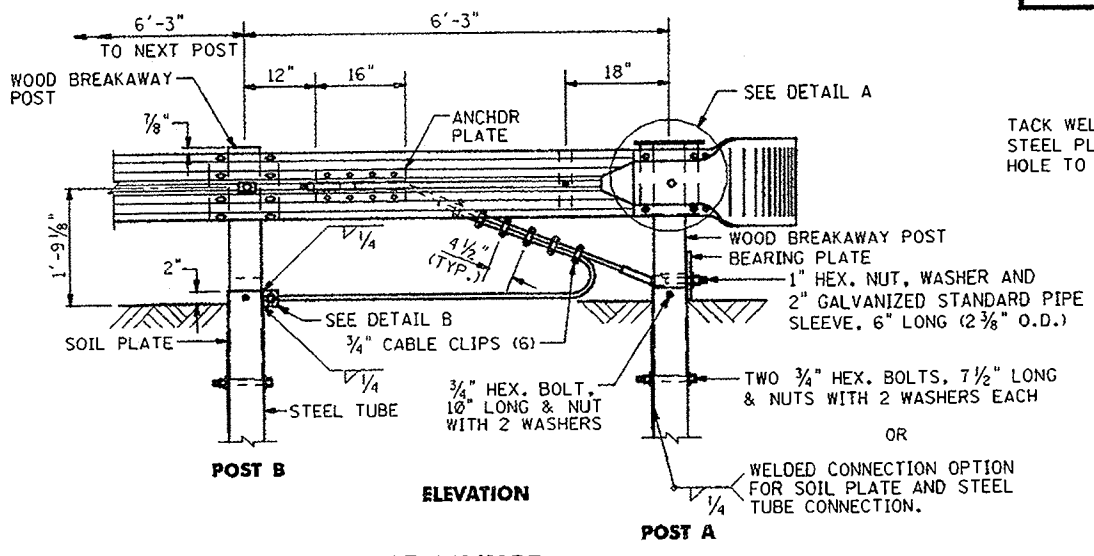
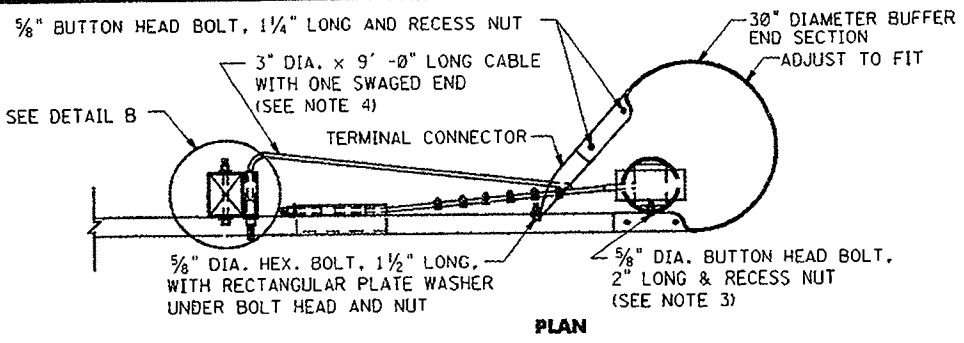
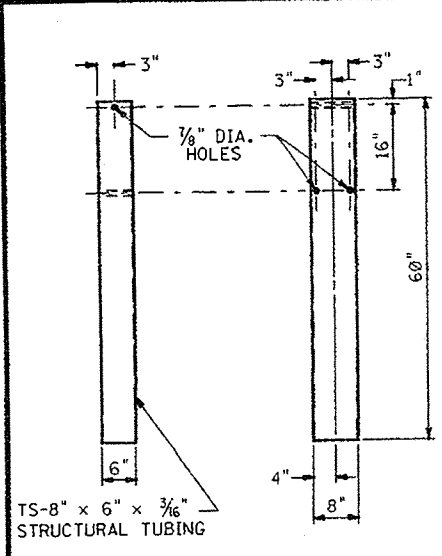

CONTROLLED RELEASE TERMINAL ANCHORAGE

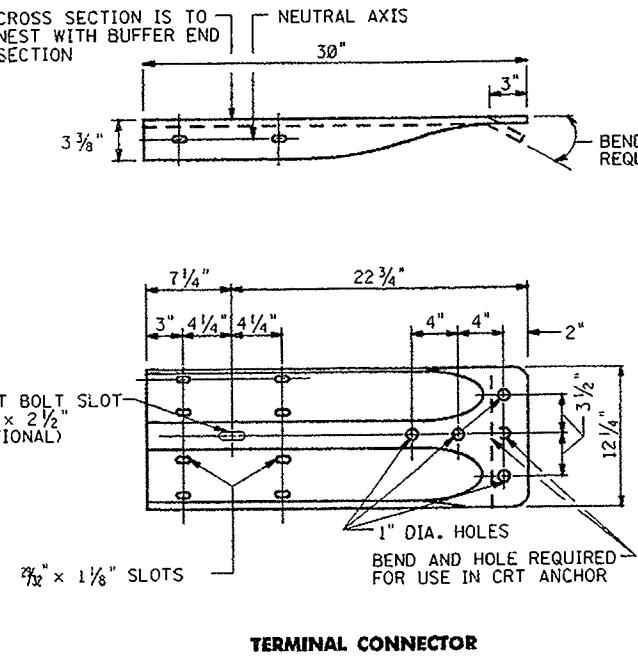

- GENERAL NOTES**
- NO WASHERS ARE USED ON THE 5/8" DIA. BUTTON HEAD BOLTS CONNECTING THE RAIL TO THE CONTROLLED RELEASE TERMINAL (CRT) POSTS.
 - FOR 8 FOOT RADIUS, THE RAIL ELEMENT SHALL NOT BE BOLTED TO THE CRT POST AT THE CENTER OF THE NOSE AS SHOWN.
 - ATTACH W-BEAM TO STEEL PIPE WITH BUTTON HEAD BOLT WITH NO WASHER. NO CONNECTION TO POST IS REQUIRED.
 - WIRE ROPE CABLE SHALL CONFORM TO THE REQUIREMENTS OF AASHTO M30 AND SHALL BE 3/4" DIAMETER PREFORMED, 6 x 19, WIRE STRAND CORE OR INDEPENDENT WIRE ROPE CORE, GALVANIZED, RIGHT REGULAR LAY, MANUFACTURED OF IMPROVED FLOW STEEL WITH A MINIMUM BREAKING STRENGTH OF 42,800 POUNDS.
 - STRUCTURAL TUBING SHALL CONFORM TO ASTM A500.
- CD-612-6-3

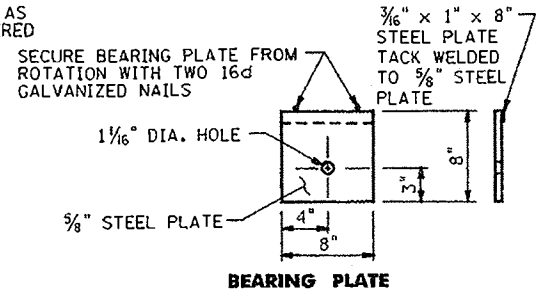
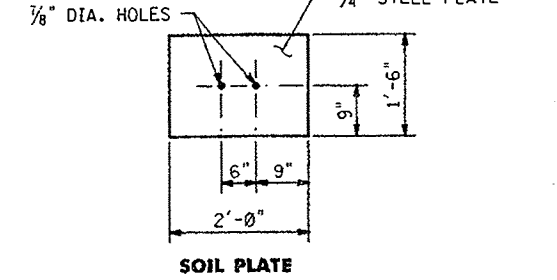
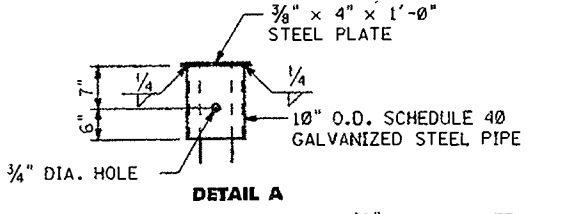
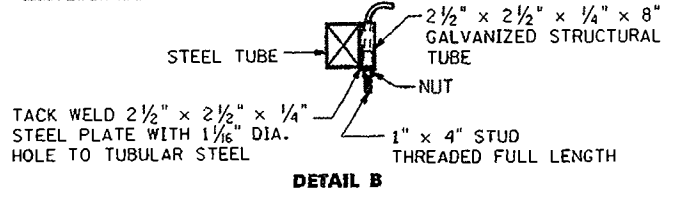

CONTROLLED RELEASE TERMINALS
N.T.S.

CD-612-6

NEW JERSEY DEPARTMENT OF TRANSPORTATION

CONSTRUCTION DETAILS

CD-612-6.2

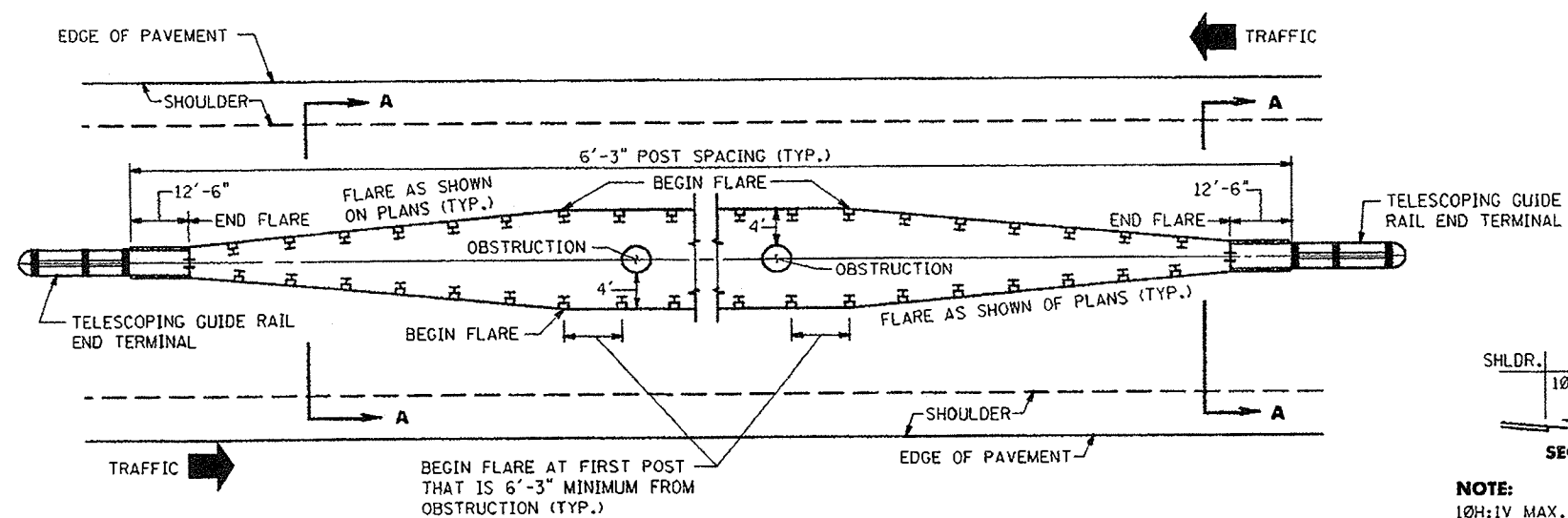

MEDIAN GUIDE RAIL WHEN CLEARANCE FROM BACK OF RAIL TO OBSTRUCTION IS 4' OR GREATER

CD-612-7.1

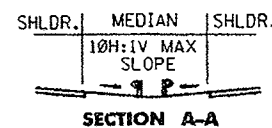

NOTE:
10H:1V MAX. SLOPES TO BEGIN 100'-0" IN ADVANCE OF GUIDE RAIL TERMINALS.

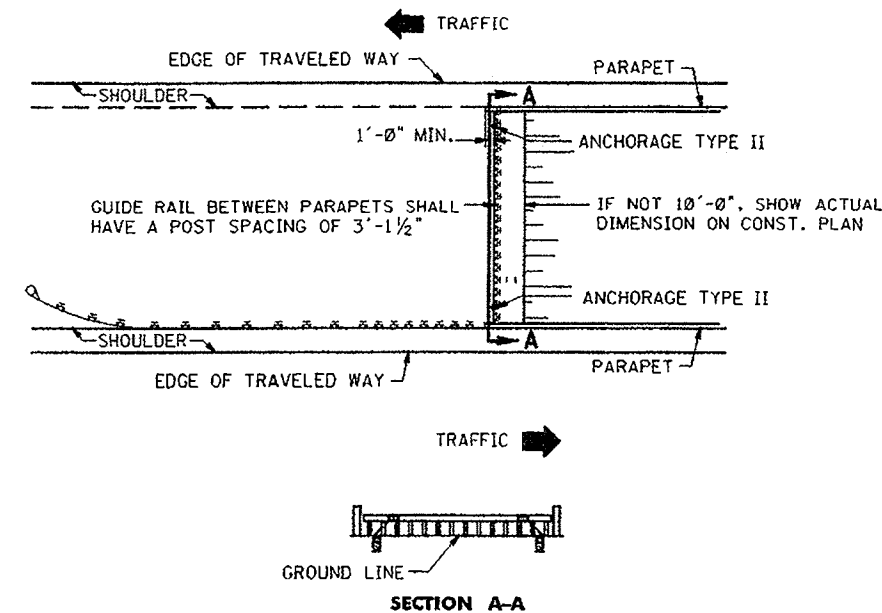

MEDIAN GUIDE RAIL TREATMENT AT ADJACENT BRIDGES

CD-612-7.4

NOTE:
REFER TO DETAIL CD-612-7.1 FOR SECTION A-A

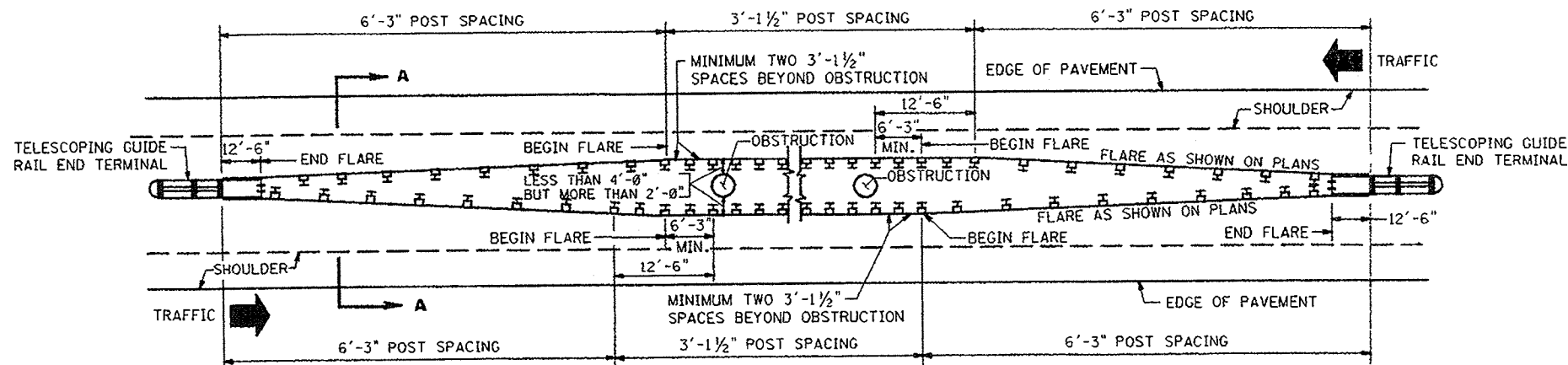

MEDIAN GUIDE RAIL WHEN CLEARANCE FROM BACK OF RAIL TO OBSTRUCTION IS MORE THAN 2' BUT LESS THAN 4'

CD-612-7.2

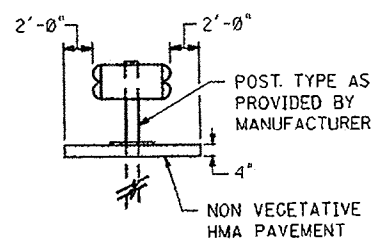

SECTION B-B

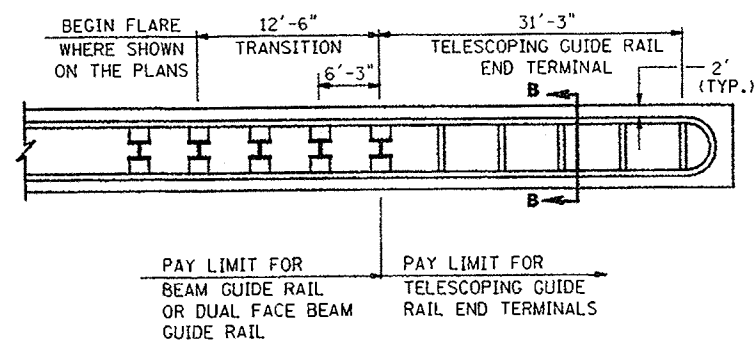

TELESCOPING GUIDE RAIL END TERMINALS

NOTE:
12'-6" OR 6'-3" TRANSITION AS RECOMMENDED BY THE MANUFACTURER- GUIDE RAIL SHALL NOT BEGIN TO FLARE WITHIN 12'-6" OF TELESCOPING GUIDE RAIL END TREATMENT.

CD-612-7.3

MEDIAN GUIDE RAIL TREATMENT

N.T.S.

HMA = HOT ASPHALT MIX

CD-612-7

NEW JERSEY DEPARTMENT OF TRANSPORTATION

CONSTRUCTION DETAILS

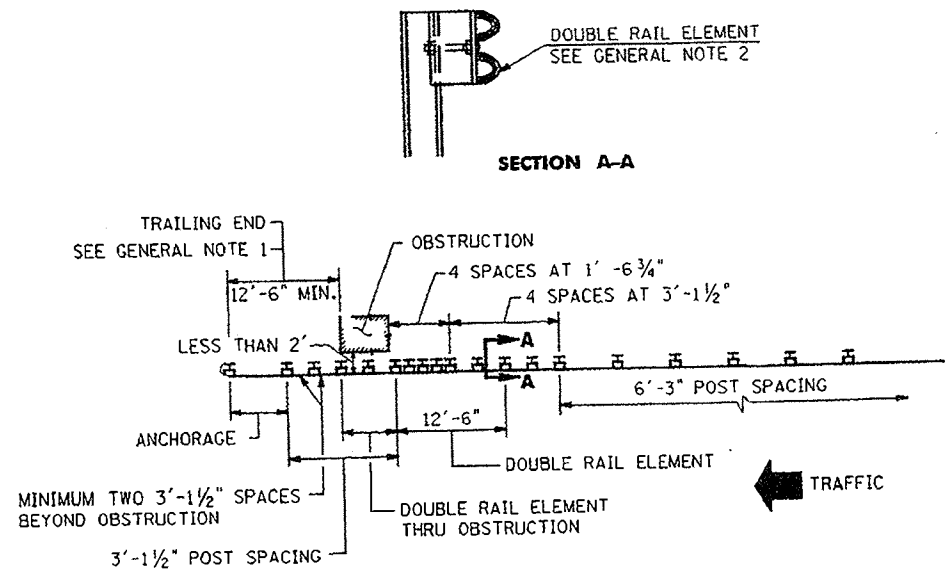

WHERE CLEARANCE FROM BACK OF RAIL TO OBSTRUCTION IS LESS THAN 2'

CD-612-8.1

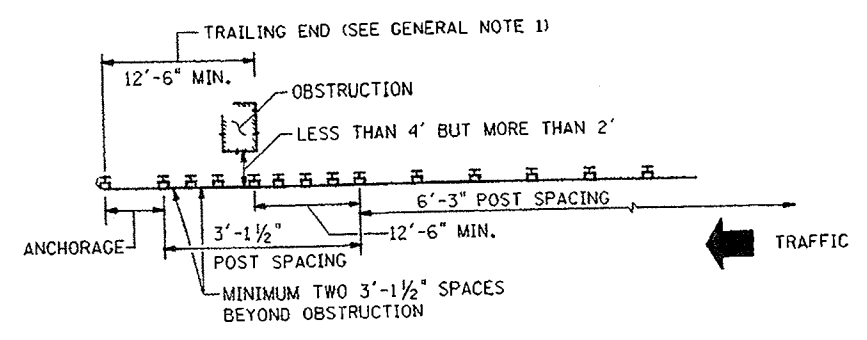

WHERE CLEARANCE FROM BACK OF RAIL TO OBSTRUCTION IS MORE THAN 2' BUT LESS THAN 4'

CD-612-8.2

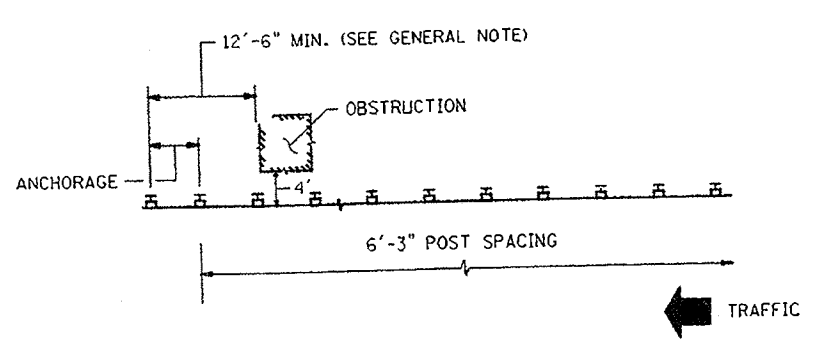

WHERE CLEARANCE FROM BACK OF RAIL TO OBSTRUCTION IS 4' OR GREATER

CD-612-8.3

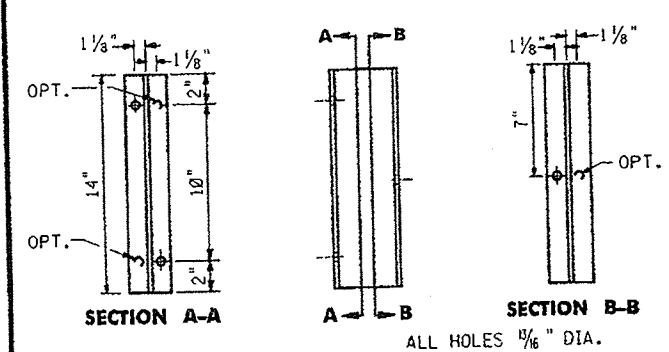

14" SPACER

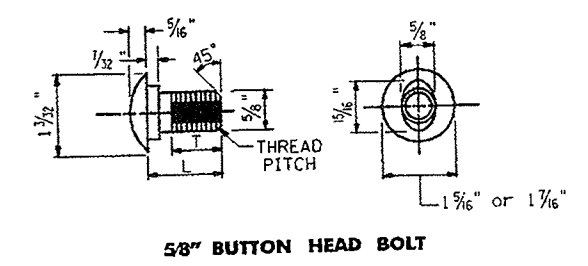

5/8" BUTTON HEAD BOLT

TYPE	L	MIN. THREAD LENGTH
SPLICE	1 3/8"	1 3/8"
RAIL	2"	1 1/2"

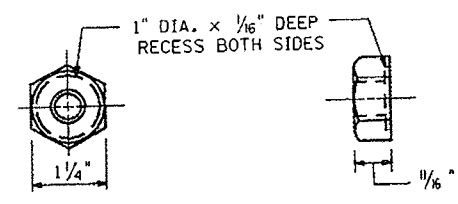

5/8" DIA. RECESS NUT SPLICE & RAIL NUT & BOLT

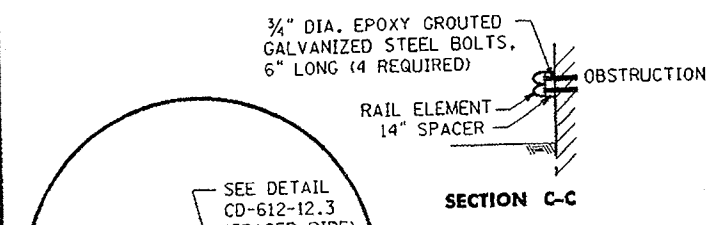

5/8" DIA. EPOXY GROUTED GALVANIZED STEEL BOLTS, 6" LONG (4 REQUIRED)

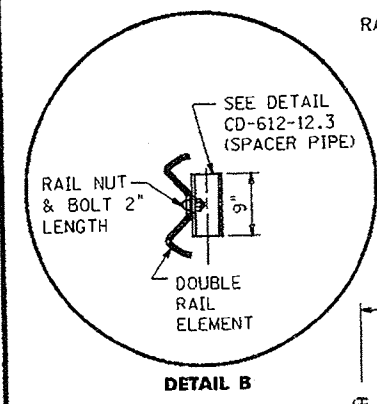

RUB RAIL BACK UP PLATE

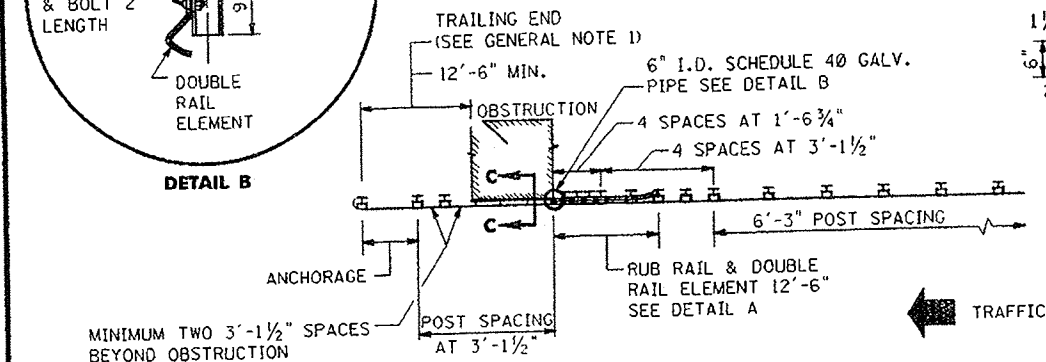

SLOPE TREATMENT AT SLOTTED GUIDE RAIL TERMINALS

CD-612-8.6

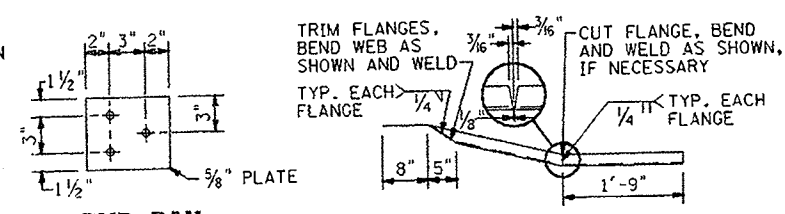

C6 x 8.2 RUB RAIL

CD-612-8.7

- GENERAL NOTES**
- WHERE A CRASHWORTHY END TREATMENT IS SHOWN AT THE TRAILING END ON THE PLANS, THE POST SPACING AND DOUBLE RAIL ELEMENT FOR THE GUIDE RAIL SHALL BE THE SAME AS THE APPROACH END.
 - WHERE DOUBLE RAIL ELEMENT IS REQUIRED, THE ADDITIONAL RAIL ELEMENT SHOULD BE ADDED BEHIND THE CONTINUOUS FRONT RAIL.

CD-612-8.8

BEAM GUIDE RAIL END TREATMENT

N.T.S.

CD-612-8

NEW JERSEY DEPARTMENT OF TRANSPORTATION

CONSTRUCTION DETAILS

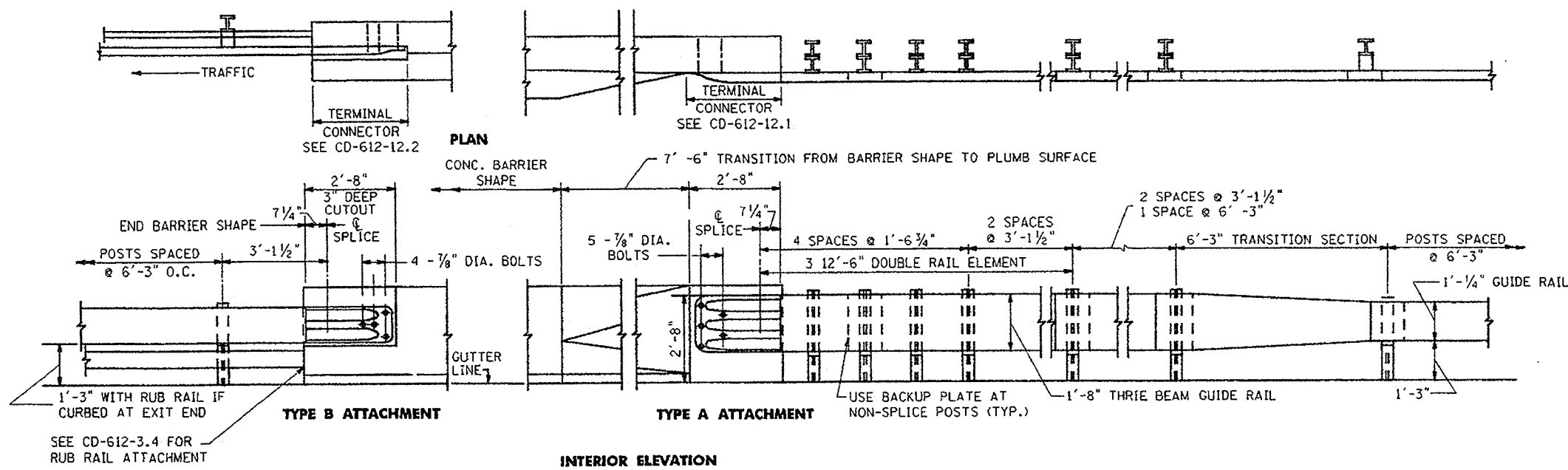

GUIDE RAIL ATTACHMENT TO BARRIER

SEE CD-612-9.4 FOR GENERAL NOTES

CD-612-9.1

CD-612-9.4

GENERAL NOTES

STRUCTURAL STEEL PLATES AND SHAPES SHALL CONFORM TO ASTM A36 AND SHALL BE GALVANIZED PER ASTM A123.

STEEL BOLTS, NUTS AND WASHERS SHALL CONFORM TO ASTM A307, UNLESS DESIGNATED AS HIGH STRENGTH. HIGH STRENGTH BOLTS, NUTS AND WASHERS SHALL CONFORM TO ASTM A325. HARDWARE SHALL BE GALVANIZED PER ASTM A153.

CONCRETE SHALL BE CLASS B CONCRETE.

REINFORCEMENT SHALL CONFORM TO ASTM A 615, GRADE 60.

HIGH STRENGTH BOLTS FOR BASE PLATE ANCHORAGE SHALL BE FULLY THREADED AND INSTALLED IN CORED HOLES NO GREATER THAN THE BOLT DIAMETER PLUS 1/4". CARE SHALL BE EXERCISED TO AVOID DAMAGE TO EXISTING REINFORCEMENT AND CONDUITS. MINIMUM EMBEDMENT LENGTH SHALL BE 6". BOLTS SHALL BE EPOXY GROUTED IN PLACE PER MANUFACTURER'S RECOMMENDATIONS TO ATTAIN A MINIMUM PULLOUT STRENGTH OF 24,000 POUNDS AT THE CONSTRUCTION SITE AS CERTIFIED BY THE CONTRACTOR.

HIGH STRENGTH BOLTS FOR BASE PLATE ANCHORAGE MAY BE CAST IN PLACE IN FRESH CONCRETE WITH A MINIMUM EMBEDMENT LENGTH OF 20".

ATTACHMENT OF TERMINAL CONNECTORS TO ABUTMENT FACES, PILSTERS OR PARAPETS ARE SIMILAR TO DETAILS SHOWN. FOR EXISTING PARAPETS OR PILASTERS USE BACKUP PLATES ON THE FAR SIDE ATTACHED BY 7/8" DIAMETER BOLTS INSTALLED IN 1" DIA. HOLES CORED THROUGH THE CONCRETE.

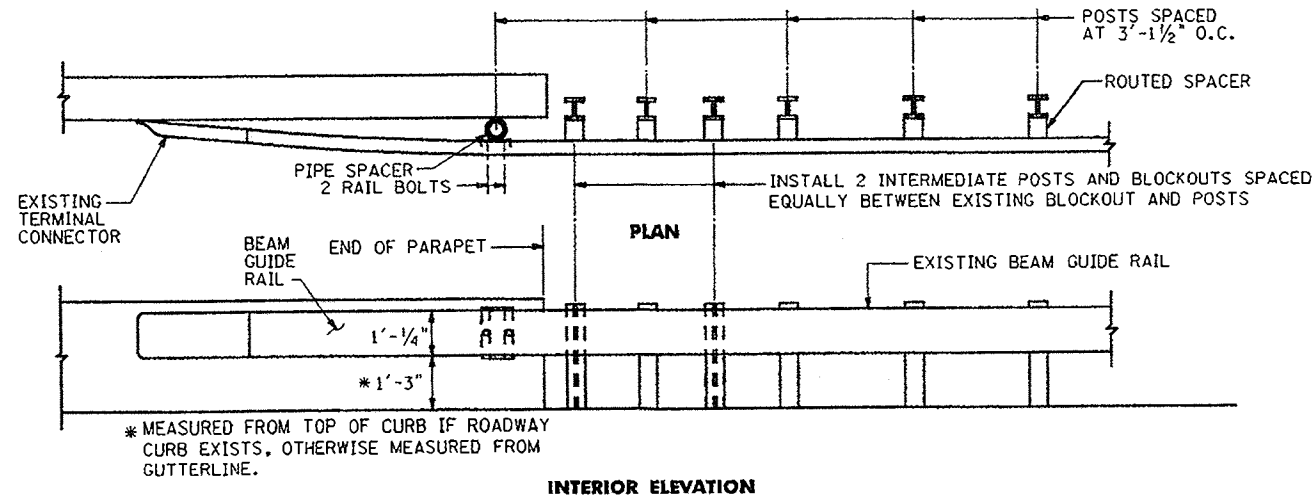

MODIFICATION OF GUIDE RAIL ATTACHMENT TO PARAPET

NOTE:
 TYPE A - PARAPET SHOWN, BARRIER SIMILAR

CD-612-9.2

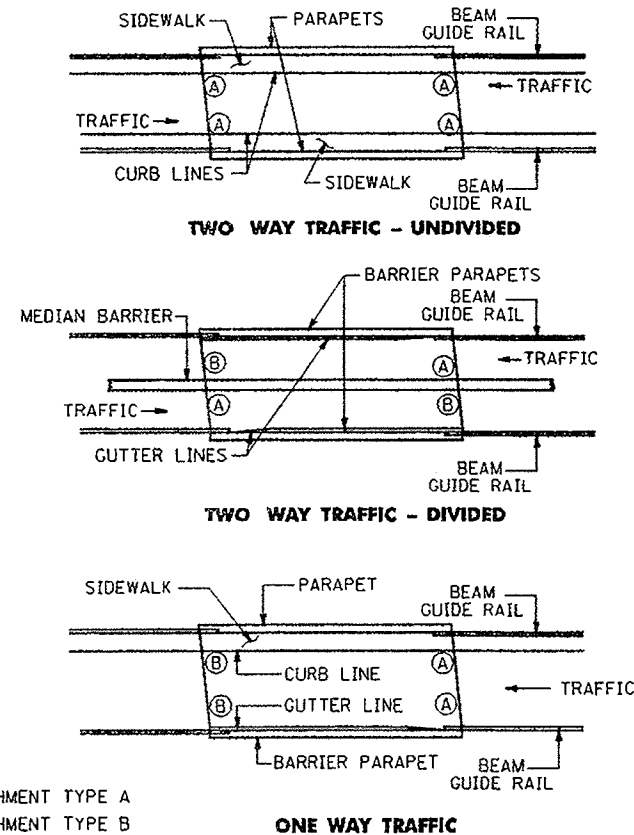

(A) ATTACHMENT TYPE A
 (B) ATTACHMENT TYPE B
 SEE CD-612-9.1

BRIDGE ATTACHMENT TYPES

BEAM GUIDE RAIL ATTACHMENTS
 N.T.S.

CD-612-9

NEW JERSEY DEPARTMENT OF TRANSPORTATION

CONSTRUCTION DETAILS

CD-612-9.3

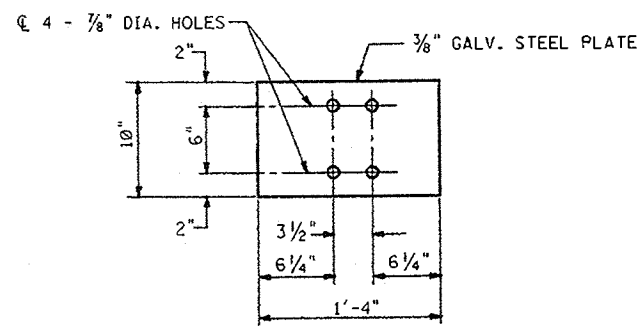

MOUNTING PLATE

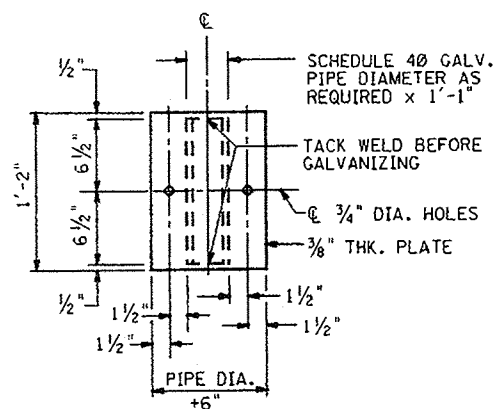

PIPE SPACER

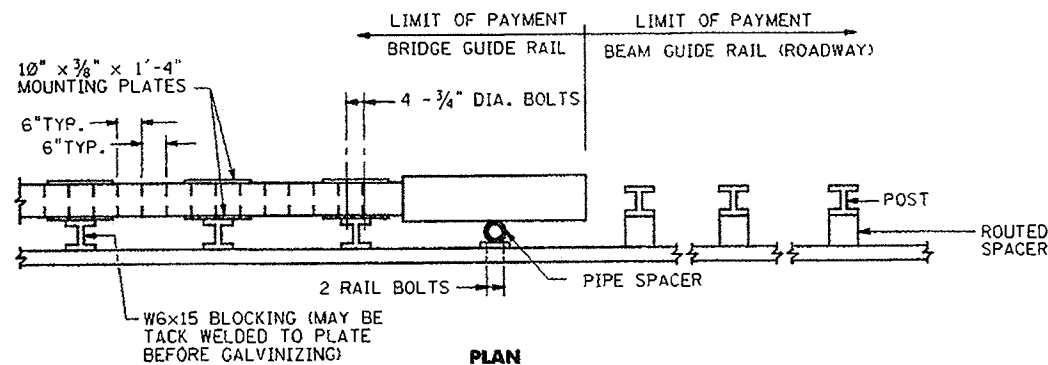

PLAN

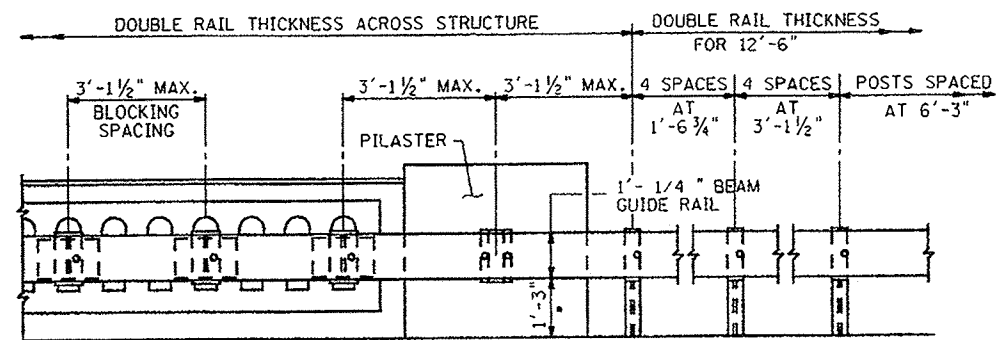

ELEVATION

*MEASURED FROM TOP OF CURB IF ROADWAY CURB EXISTS, OTHERWISE MEASURED FROM GUTTERLINE.

SEE CD-612-9.4 FOR GENERAL NOTES

GUIDE RAIL ATTACHMENT TO BALUSTRADE

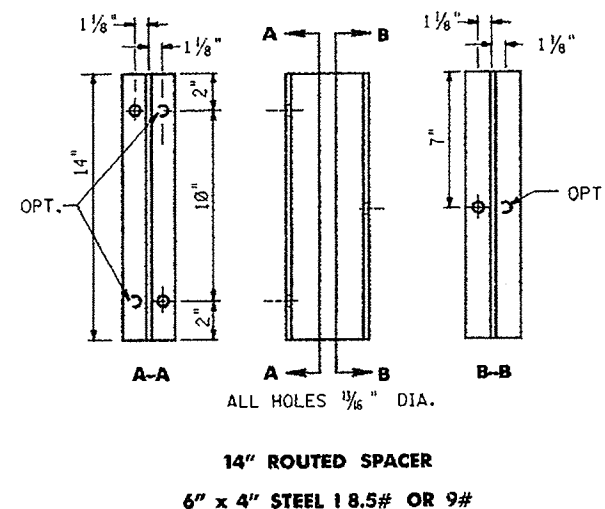

14" ROUTED SPACER
6" x 4" STEEL I 8.5# OR 9#

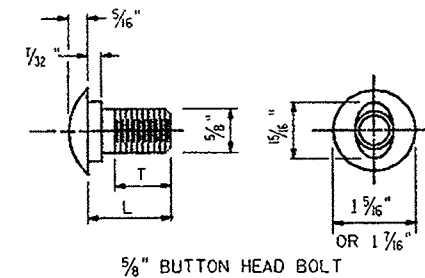

5/8" BUTTON HEAD BOLT

TYPE	L	T
SPLICE	1 1/4"	1 1/4"
RAIL	2"	1 1/2"

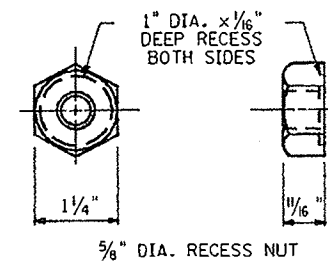

SPICE & RAIL NUT & BOLT

CD-612-10.1

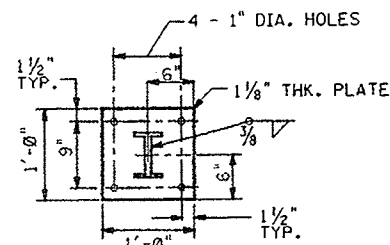

BASE PLATE

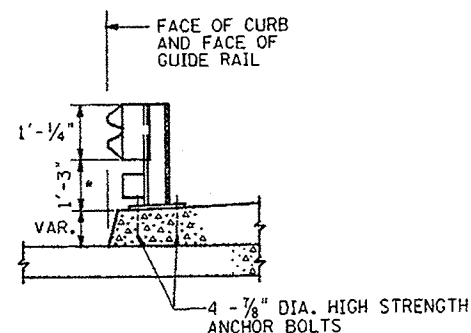

SECTION

*MEASURED FROM TOP OF CURB IF ROADWAY CURB EXISTS, OTHERWISE MEASURED FROM GUTTER LINE.

SEE CD-612-9.4 FOR GENERAL NOTES

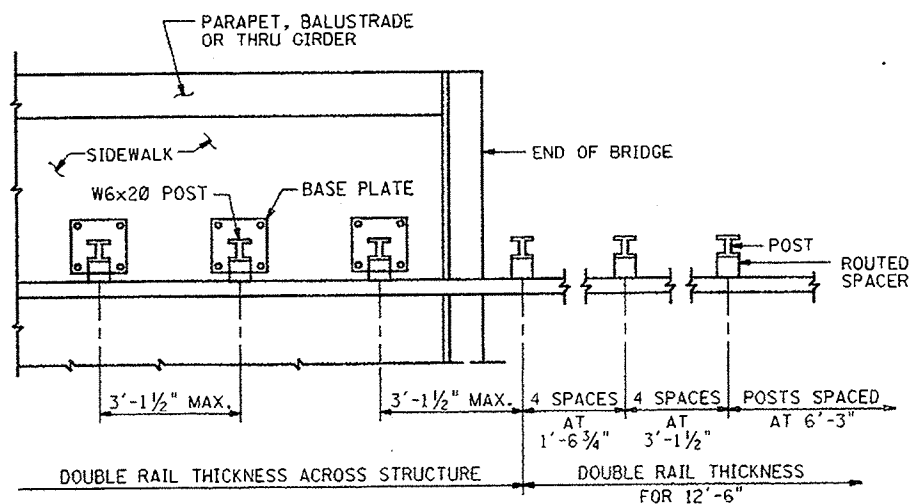

PLAN

GUIDE RAIL ATTACHMENT TO SIDEWALK

CD-612-10.2

BEAM GUIDE RAIL ATTACHMENTS

N.T.S.

CD-612-10

NEW JERSEY DEPARTMENT OF TRANSPORTATION

CONSTRUCTION DETAILS

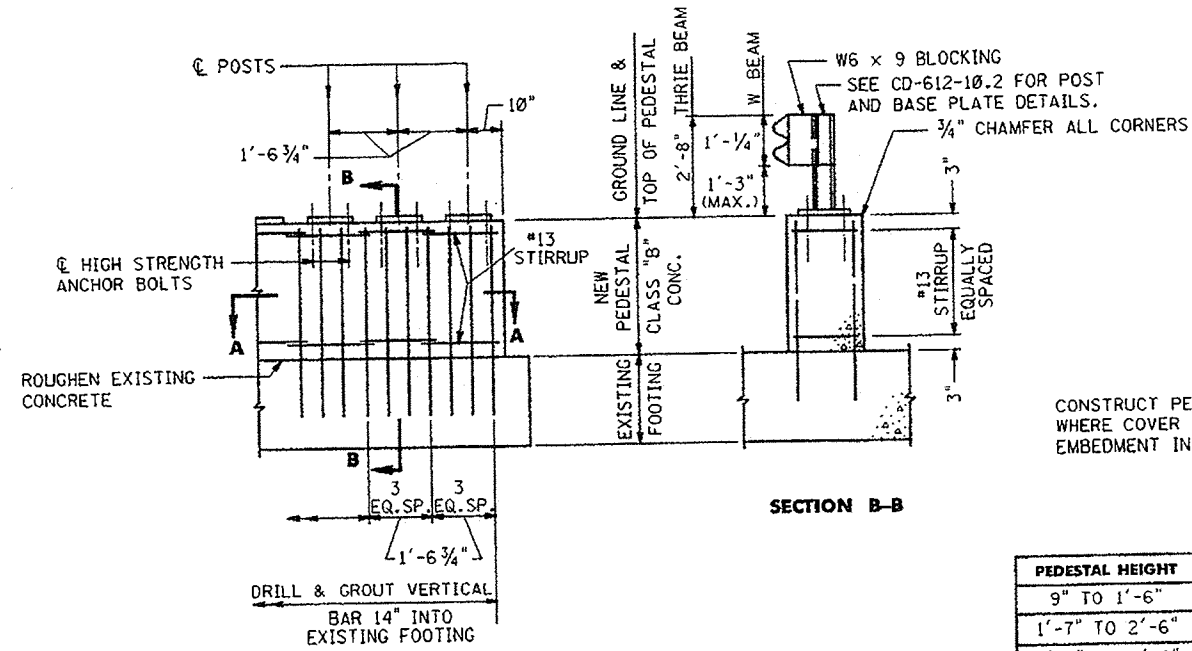
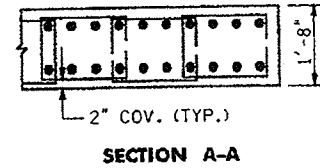
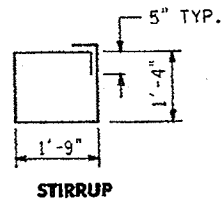

PEDESTAL HEIGHT	VERTICAL BARS	STIRRUPS
9" TO 1'-6"	#16	2 - #13
1'-7" TO 2'-6"	#16	3 - #13
2'-7" TO 3'-6"	#16	4 - #13
3'-7" TO 4'-0"	#16	5 - #13

GUIDE RAIL ATTACHMENT TO FOOTING

SEE CD-612-9.4 FOR GENERAL NOTES

CD-612-11.1

NOTES:

REINFORCING BARS ARE IN METRIC UNITS.

BEAM GUIDE RAIL ATTACHMENTS

N.T.S.

CD-612-11

NEW JERSEY DEPARTMENT OF TRANSPORTATION

CONSTRUCTION DETAILS

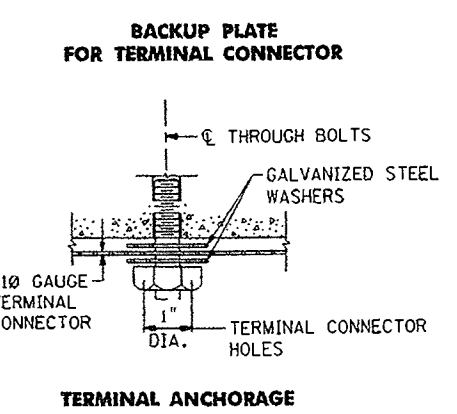
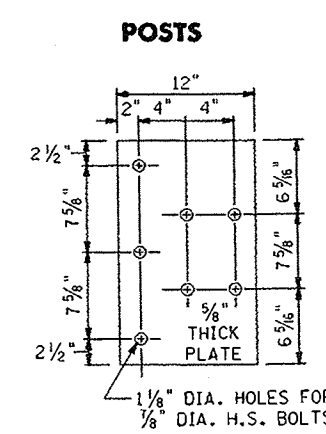
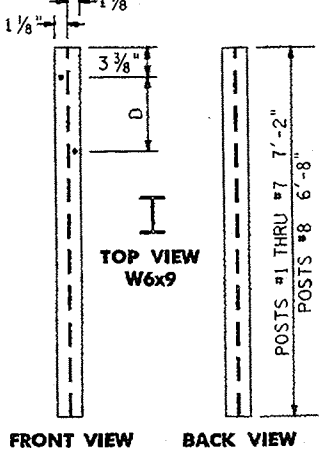
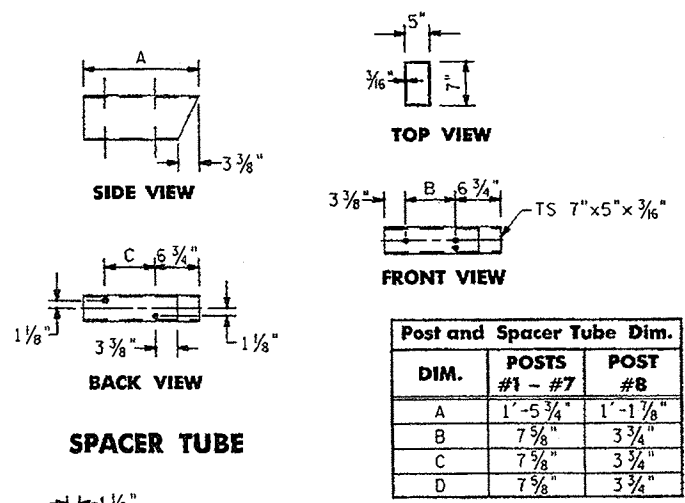

SEE CD-612-9.4 FOR GENERAL NOTES

- NOTES:**
1. STEEL FOR STRUCTURAL TUBE SPACER BLOCKS SHALL MEET ASTM A500 GRADE B.
 2. STEEL FOR WIDE-FLANGE SHALL MEET ASTM A36.
 4. GALVANIZED
 5. ALL HOLES DRILLED OR PUNCHED TO 3/4" DIA.

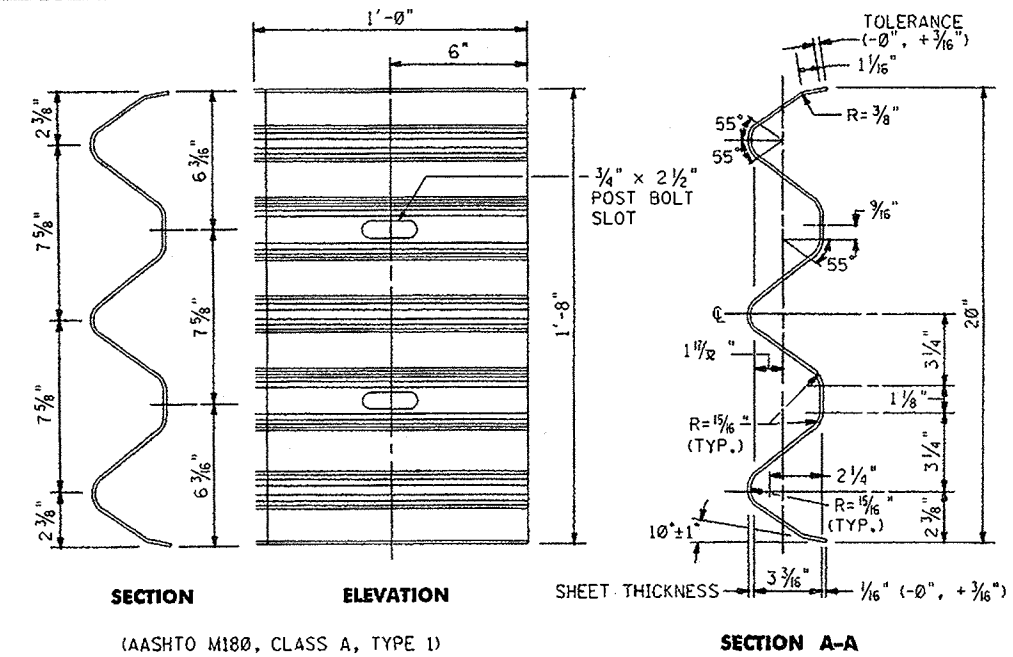

BACKUP PLATE AT NON SPLICE POSTS

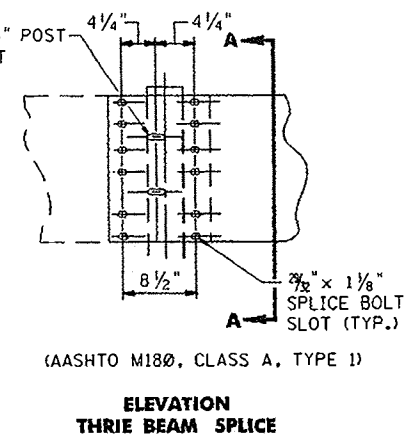
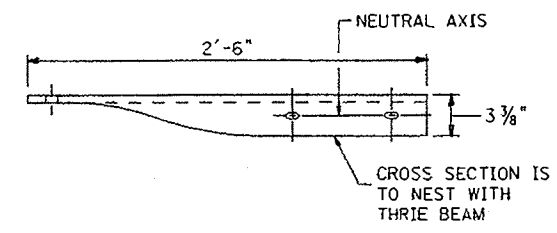

ELEVATION THRIE BEAM SPLICE

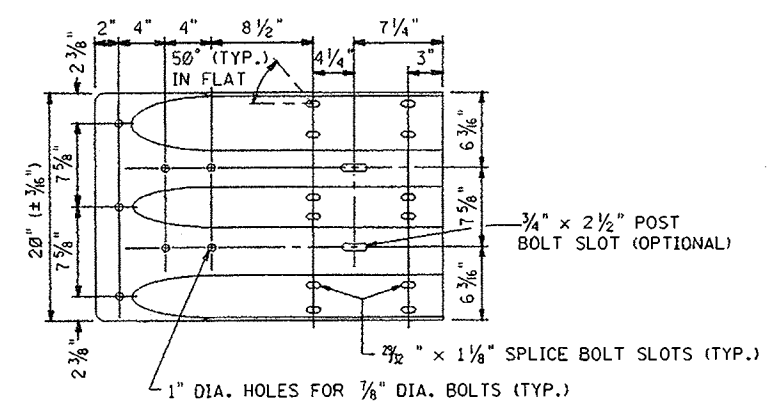

TERMINAL CONNECTOR

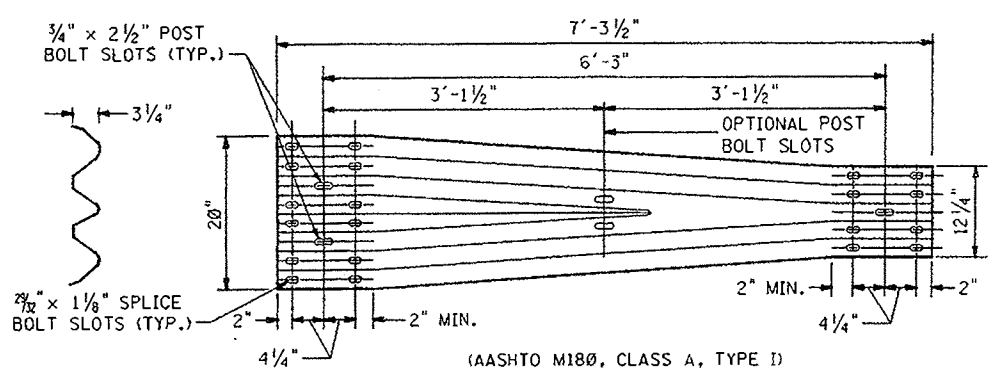

THRIE BEAM

W - THRIE BEAM TRANSITION SECTION

CD-612-12.1

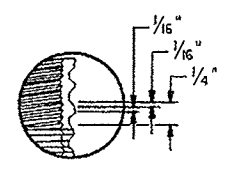
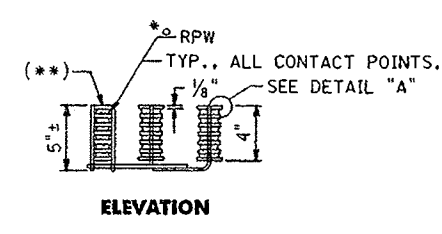
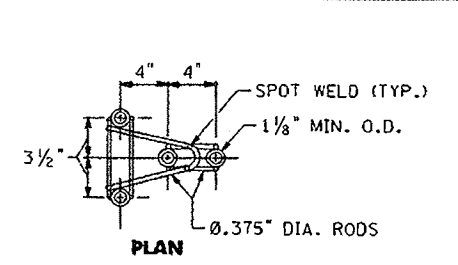

DETAIL "A"

SEE CD-612-12.1 FOR TERMINAL ANCHORAGE

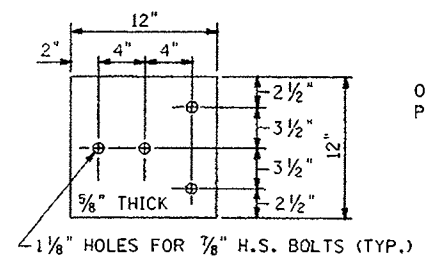

BACKUP PLATE FOR TERMINAL CONNECTOR

SEE CD-612-9.4 FOR GENERAL NOTES

W BEAM TERMINAL CONNECTOR

NOTES:

- * EACH WELDED ATTACHMENT OF WIRE TO FERRULE SHALL DEVELOP THE TENSILE STRENGTH OF THE WIRE.
- (**) THREADED STEEL INSERT WITH SOLID BOTTOM TAPPED TO A MINIMUM THREADED DEPTH OF 2 1/2" FOR USE WITH 3/8" - 9 x 2 1/2" GALVANIZED H.S. HEX BOLT & A 1 5/16" I.D., 2 1/4" O.D., 5/32" THICK, TYPE A, PLAIN WASHER.
- FOUR (4) BOLTS AND FOUR (4) WASHERS TO BE PROVIDED WITH EACH ASSEMBLY.
- WIRES SHOWN ARE MINIMUM ALLOWABLE SIZE AND SHALL CONFORM TO THE REQUIREMENT OF ASTM A510, GRADE 1030 AND HAVE A MINIMUM TENSILE STRENGTH OF 100,000 P.S.I..
- FERRULES SHALL BE MADE OF STEEL MEETING THE REQUIREMENTS OF ASTM A108, GRADE 12L14. INSERTS SHALL BE TAPPED TO THE DIMENSIONAL REQUIREMENTS SPECIFIED IN ASTM A563 FOR NUTS RECEIVING GALVANIZED BOLTS.
- BOLTS SHALL CONFORM TO THE REQUIREMENTS OF ASTM A325 OR A449 AND SHALL BE THREADED FULL LENGTH, WASHERS SHALL BE MADE OF STEEL AND SHALL MEET THE DIMENSIONAL REQUIREMENTS OF ASTM B272 TYPE A PLAIN WASHERS. BOTH SHALL BE GALVANIZED IN ACCORDANCE WITH ASTM A153.
- WIRE DIAMETERS, MATERIALS REQUIREMENTS, FERRULE MATERIALS REQUIREMENTS AND EXTERNAL DIAMETERS MAY BE ALTERED PROVIDED MANUFACTURER DEMONSTRATES REVISED DESIGN IS EQUIVALENT TO THE DESIGN SHOWN IN THIS STANDARD.
- DIMENSIONAL TOLERANCE NOT SHOWN OR IMPLIED ARE INTENDED TO BE THOSE CONSISTENT WITH THE PROPER FUNCTIONING OF THE PART, INCLUDING ITS APPEARANCE, AND ACCEPTED MANUFACTURING PRACTICE.

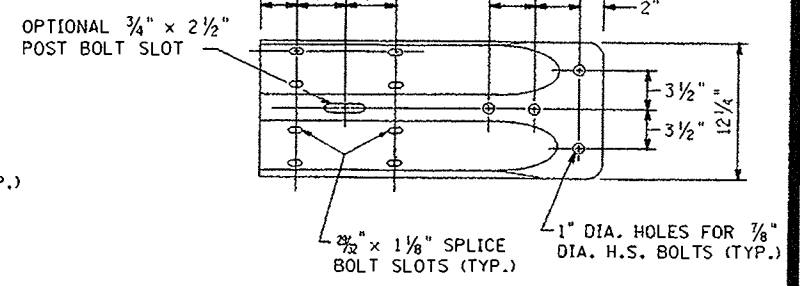
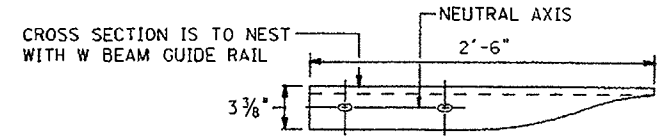

TERMINAL CONNECTOR

THRIE BEAM AND W BEAM TERMINAL CONNECTOR

N.T.S.

CD-612-12

NEW JERSEY DEPARTMENT OF TRANSPORTATION

CONSTRUCTION DETAILS

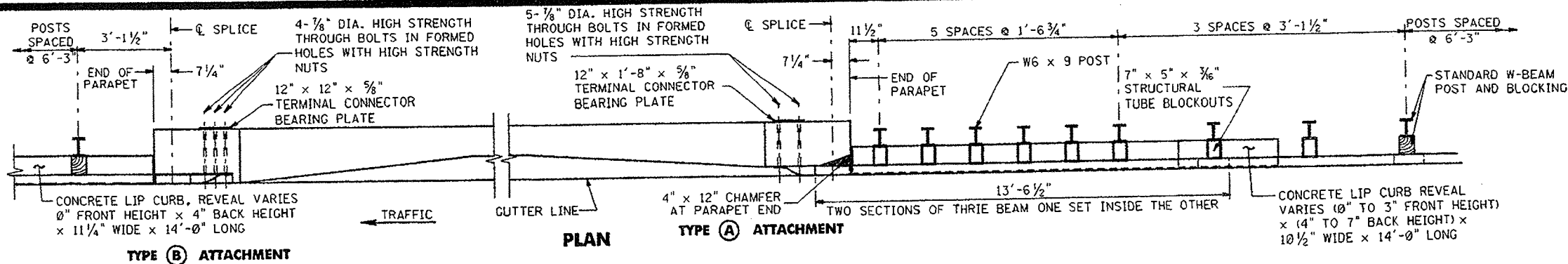

NOTES:

1. THIS GUIDE RAIL TRANSITION IS APPROPRIATE FOR CONNECTION TO A VERTICAL CONCRETE SHAPE AND SHOULD NOT BE CONNECTED DIRECTLY TO A CONCRETE SAFETY SHAPE. CONCRETE SAFETY BARRIER SHOULD BE TRANSITIONED TO A VERTICAL SHAPE AT THE GUIDE RAIL CONNECTION.
2. FOR RECOMMENDED ATTACHMENT, REFER TO "BRIDGE ATTACHMENT TYPES", THIS SHEET.
3. ALL CROSS SLOPES BETWEEN THE PAVEMENT EDGE AND POSTS SHALL BE 10H:1V OR FLATTER.
4. EMBANKMENT MATERIAL CONFORMING TO THE NJDOT STANDARD SPECIFICATIONS SECTION 203 SHALL EXTEND FLAT BEHIND THE POSTS AT LEAST 2'-0" AT WHICH POINT A SLOPE OF NO STEEPER THAN 2H:1V SHOULD EXTEND A MINIMUM OF 4'-0" FURTHER.
5. BARRIER PARAPET END MAY HAVE TO BE RECONFIGURED TO ACCEPT DIFFERENT TYPES OF RAILING OR FENCING THAT MAY BE MOUNTED ON TOP OF THE PARAPET.
6. AT TYPE (A) ATTACHMENTS, THRIE BEAM RAIL ELEMENT WILL REQUIRE ADDITIONAL POST MOUNTING HOLES FOR POST #1, #3 AND #5. CAUTION, HOLES ARE TO BE SHOP PUNCHED OR DRILLED BEFORE GALVANIZATION. NO FIELD DRILLING IS PERMITTED.
7. POSTS 1 THRU 7 SHALL BE 7'-2" LONG WITH 4'-10" POST EMBEDMENT. POST 8 SHALL BE 6'-8" LONG WITH 4'-6" POST EMBEDMENT. POST 9 SHALL BE 6'-8" LONG WITH 4'-4" POST EMBEDMENT.
8. LOCATE CONDUIT AT END OF BARRIER PARAPETS SO AS NOT TO INTERFERE WITH GUIDE RAIL POST SPACING.
9. LOCATE DRAINAGE INLETS AND ELECTRICAL JUNCTION BOXES ON APPROACHES SO AS NOT TO INTERFERE WITH GUIDE RAIL POST SPACING.
10. STRUCTURAL STEEL PLATES AND SHAPES SHALL CONFORM TO AASHTO M270 AND SHALL BE GALVANIZED PER AASHTO M111.
11. HIGH STRENGTH STEEL BOLTS, NUTS AND WASHERS SHALL CONFORM TO AASHTO M164. ZINC COATED BOLTS, NUTS AND WASHERS SHALL BE TREATED ACCORDING TO AASHTO M232M.
12. THE THICKNESS OF THRIE-BEAM, W-BEAM AND W-THRIE BEAM TRANSITION SHALL BE 12-GAUGE.
13. FOR ADDITIONAL THRIE BEAM AND W-BEAM DETAILS REFER TO CD-605-1.9, CD-612-1, CD-612-3, AND CD-612-12.

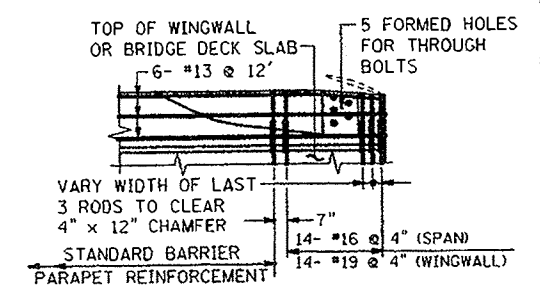
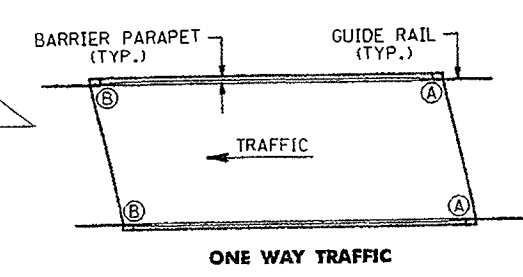
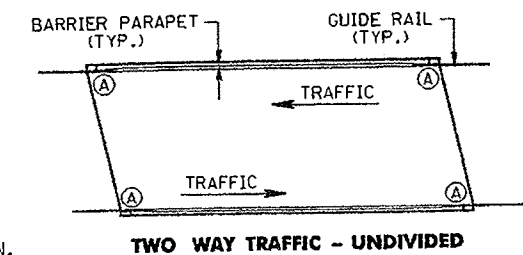
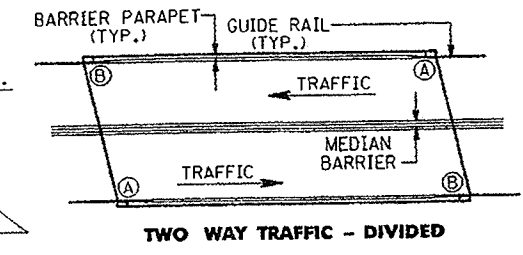
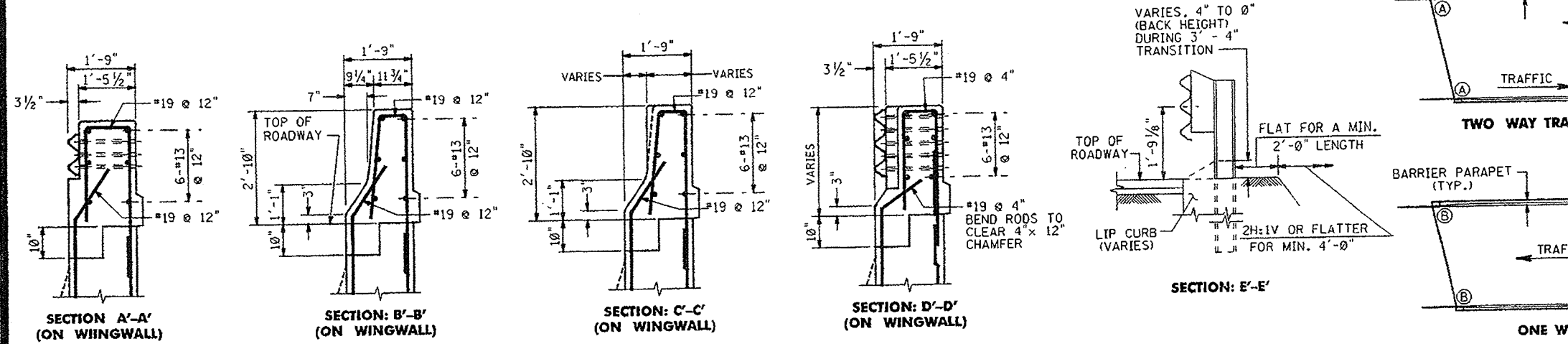
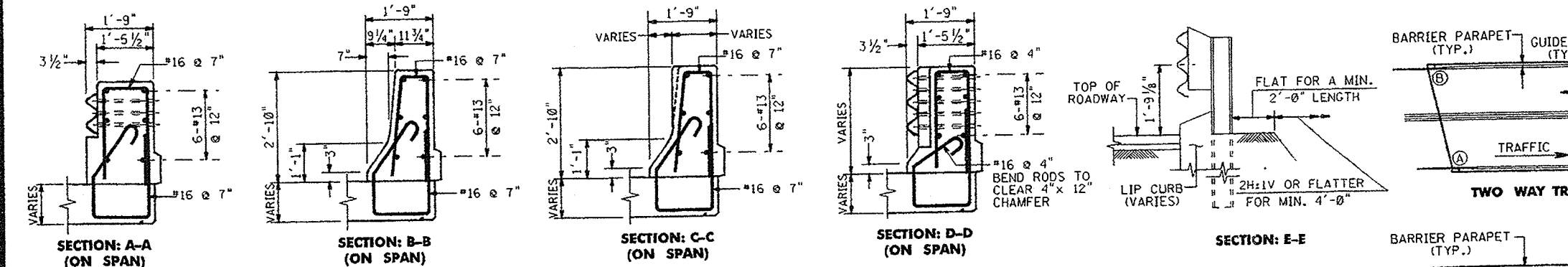
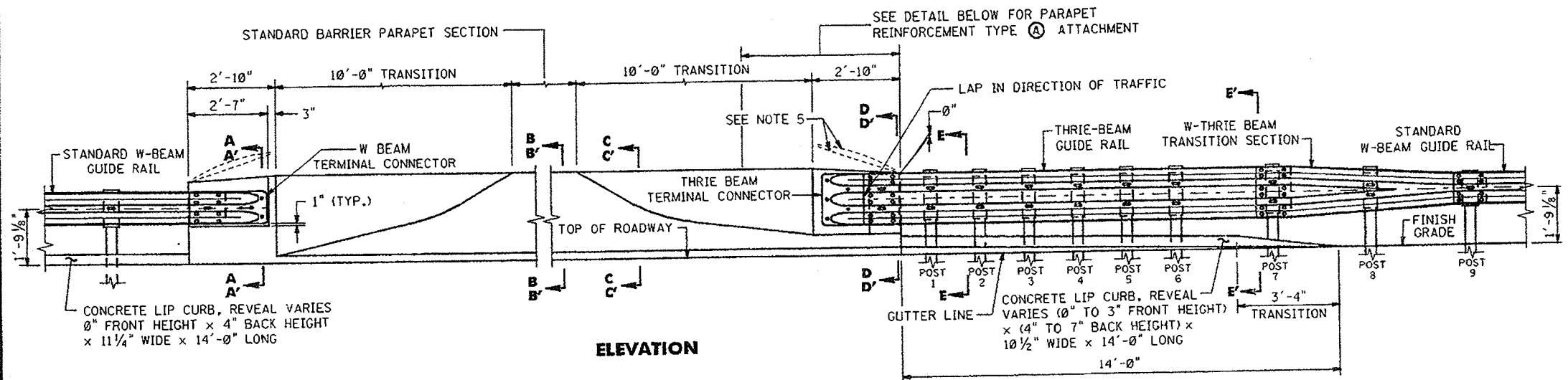

INTERIOR ELEVATION PARAPET REINFORCEMENT TYPE (A) ATTACHMENT

NOTE: REINFORCING BARS ARE IN METRIC UNITS.

BEAM GUIDE RAIL ATTACHMENTS

N.T.S.

GUIDE RAIL ATTACHMENT - NEW CONSTRUCTION
NEW JERSEY BARRIER SHAPE PARAPET (NO ROADWAY CURBING ON APPROACH)

CD-612-13.1

CD-612-13

NEW JERSEY DEPARTMENT OF TRANSPORTATION

CONSTRUCTION DETAILS

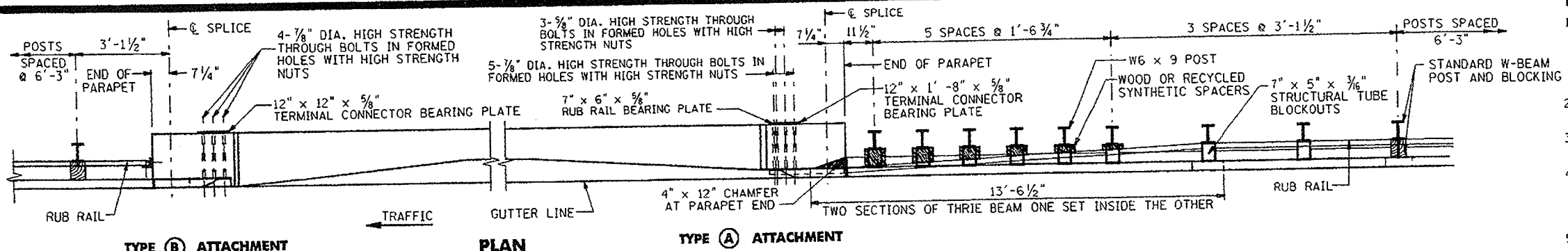

- NOTES:**
1. THIS GUIDE RAIL TRANSITION IS APPROPRIATE FOR CONNECTION TO A VERTICAL CONCRETE SHAPE AND SHOULD NOT BE CONNECTED DIRECTLY TO A CONCRETE SAFETY SHAPE. CONCRETE SAFETY BARRIER SHOULD BE TRANSITIONED TO A VERTICAL SHAPE AT THE GUIDE RAIL CONNECTION.
 2. FOR RECOMMENDED ATTACHMENT, REFER TO "BRIDGE ATTACHMENT TYPES", THIS SHEET.
 3. ALL CROSS SLOPES BETWEEN THE PAVEMENT EDGE AND POSTS SHALL BE 1V:10H OR FLATTER.
 4. EMBANKMENT MATERIAL CONFORMING TO THE NJDOT STANDARD SPECIFICATIONS SECTION 203 SHALL EXTEND FLAT BEHIND THE POSTS AT LEAST 2'-0" AT WHICH POINT A SLOPE OF NO STEEPER THAN 1V:2H SHOULD EXTEND A MINIMUM OF 4'-0" FURTHER.
 5. BARRIER PARAPET END MAY HAVE TO BE RECONFIGURED TO ACCEPT DIFFERENT TYPES OF RAILING OR FENCING THAT MAY BE MOUNTED ON TOP OF THE PARAPET.
 6. AT TYPE (A) ATTACHMENTS, THRIE BEAM RAIL ELEMENT WILL REQUIRE ADDITIONAL POST MOUNTING HOLES FOR POST #1, #3 AND #5. CAUTION, HOLES ARE TO BE SHOP PUNCHED OR DRILLED BEFORE GALVANIZATION. NO FIELD DRILLING IS PERMITTED.
 7. POSTS 1 THRU 7 SHALL BE 7'-2" LONG WITH 4'-10" POST EMBEDMENT. POST 8 SHALL BE 6'-8" LONG WITH 4'-6" POST EMBEDMENT. POST 9 SHALL BE 6'-8" LONG WITH 4'-4" POST EMBEDMENT.
 8. TRANSITION LAST 10 FEET OF ROADWAY CURBING TO MATCH BARRIER PARAPET SHAPE.
 9. LOCATE CONDUIT AT END OF BARRIER PARAPETS SO AS NOT TO INTERFERE WITH GUIDE RAIL POST SPACING.
 10. LOCATE DRAINAGE INLETS AND ELECTRICAL JUNCTION BOXES ON APPROACHES SO AS TO NOT INTERFERE WITH GUIDE RAIL POST SPACING.
 11. STRUCTURAL STEEL PLATES AND SHAPES SHALL CONFORM TO AASHTO M270 AND SHALL BE GALVANIZED PER AASHTO M111.
 12. HIGH STRENGTH STEEL BOLTS, NUTS AND WASHERS SHALL CONFORM TO AASHTO M164. ZINC COATED BOLTS, NUTS AND WASHERS SHALL BE TREATED ACCORDING TO AASHTO M232M.
 13. THE THICKNESS OF THRIE-BEAM, W-BEAM AND W-THRIE BEAM TRANSITION SHALL BE 12-GAUGE.
 14. FOR ADDITIONAL THRIE BEAM AND W-BEAM DETAILS REFER TO CD-605-1.9, CD-612-1, CD-612-3, AND CD-612-12.

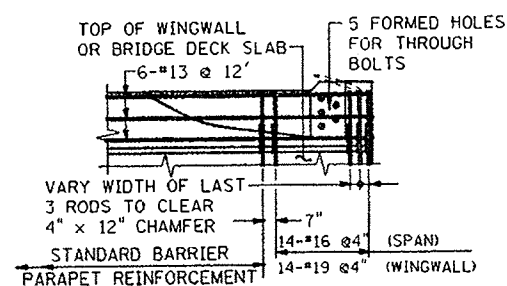
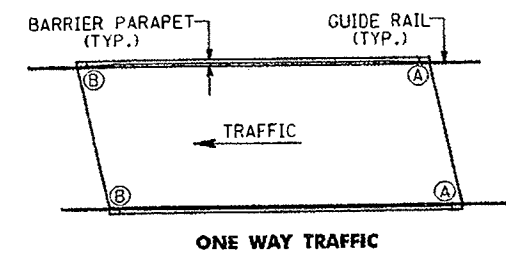
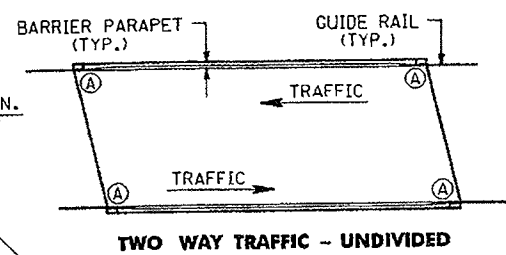
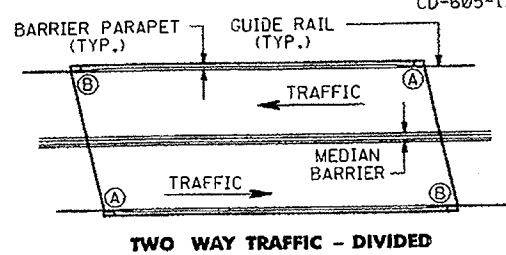
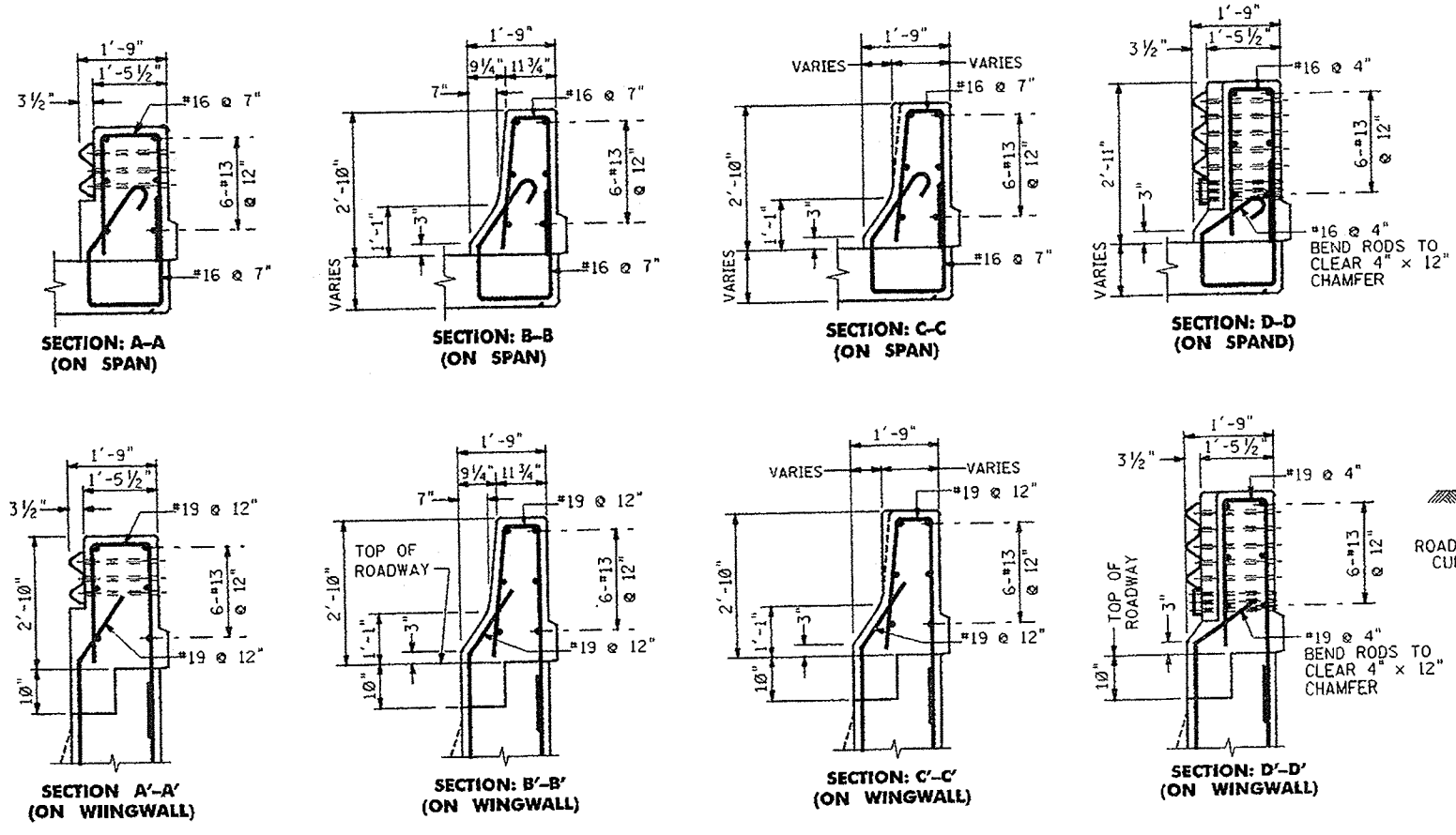
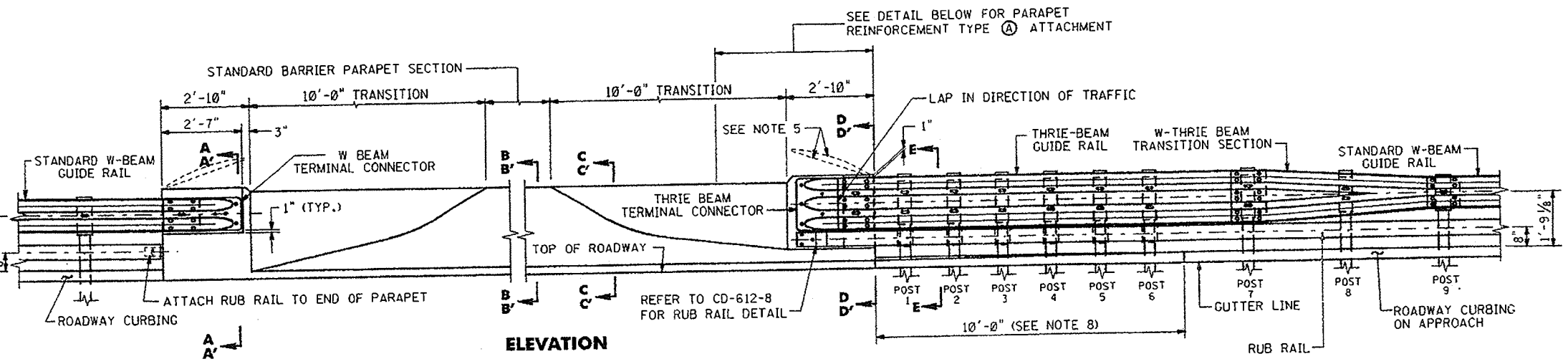

INTERIOR ELEVATION PARAPET REINFORCEMENT TYPE (A) ATTACHMENT

NOTE: REINFORCING BARS ARE IN METRIC UNITS.

BEAM GUIDE RAIL ATTACHMENTS

N.T.S. CD-612-14

NEW JERSEY DEPARTMENT OF TRANSPORTATION

CONSTRUCTION DETAILS

**GUIDE RAIL ATTACHMENT - NEW CONSTRUCTION
NEW JERSEY BARRIER SHAPE PARAPET (WITH ROADWAY CURBING ON APPROACH)**

CD-612-14.1

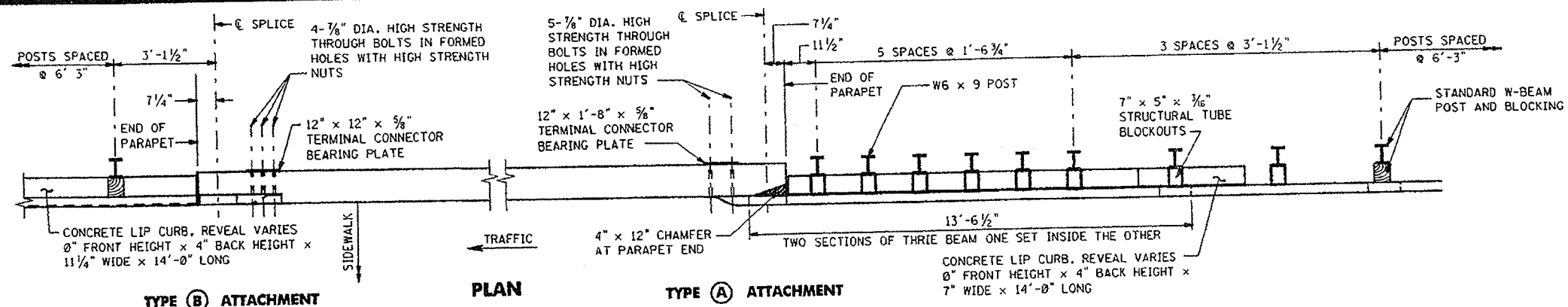

- NOTES:**
1. THIS GUIDE RAIL TRANSITION IS APPROPRIATE FOR CONNECTION TO A VERTICAL CONCRETE SHAPE.
 2. FOR RECOMMENDED ATTACHMENT TYPE, REFER TO "BRIDGE ATTACHMENT TYPES", THIS SHEET.
 3. ALL CROSS SLOPES BETWEEN THE PAVEMENT EDGE AND POSTS SHALL BE 10H:1V OR FLATTER.
 4. EMBANKMENT MATERIAL CONFORMING TO THE NJDOT STANDARD SPECIFICATIONS SECTION 203 SHALL EXTEND FLAT BEHIND THE POSTS AT LEAST 2'-0" AT WHICH POINT A SLOPE OF NO STEEPER THAN 2H:1V SHOULD EXTEND A MINIMUM OF 4'-0" FURTHER.
 5. WHEN RAILING IS INSTALLED ON TOP OF PARAPET, PARAPET END SHALL BE MODIFIED TO ACCOMMODATE HORIZONTAL RAIL ATTACHMENT TO PARAPET. REFER TO STANDARD RAILING PLATE FOR ATTACHMENT DETAILS.
 6. AT TYPE (A) ATTACHMENTS, THRIE BEAM RAIL ELEMENT WILL REQUIRE ADDITIONAL POST MOUNTING HOLES FOR POST #1, 3 & 5. CAUTION, HOLES ARE TO BE SHOP PUNCHED OR DRILLED BEFORE GALVANIZATION. NO FIELD DRILLING IS PERMITTED.
 7. POSTS 1 THRU 7 SHALL BE 7'-2" LONG WITH 4'-10" POST EMBEDMENT. POST 8 SHALL BE 6'-8" LONG WITH 4'-6" POST EMBEDMENT. POST 9 SHALL BE 6'-8" LONG WITH 4'-4" POST EMBEDMENT.
 8. LOCATE CONDUIT AT END OF PYLON SO AS NOT TO INTERFERE WITH GUIDE RAIL POST SPACING.
 9. LOCATE DRAINAGE INLETS AND ELECTRIC JUNCTION BOXES ON APPROACHES SO AS NOT TO INTERFERE WITH GUIDE RAIL POST SPACING.
 10. STRUCTURAL STEEL PLATES AND SHAPES SHALL CONFORM TO AASHTO M270 AND SHALL BE GALVANIZED AS PER AASHTO M111.
 11. HIGH STRENGTH STEEL BOLTS, NUTS AND WASHERS SHALL CONFORM TO AASHTO M164. ZINC COATED BOLTS, NUTS AND WASHERS SHALL BE TREATED ACCORDING TO AASHTO M232M.
 12. THE THICKNESS OF THRIE-BEAM, W-BEAM AND W-THRIE BEAM TRANSITION SHALL BE 12-GAUGE.
 13. FOR ADDITIONAL THRIE BEAM AND W-BEAM DETAILS REFER TO CD-605-1.9, CD-612-1, CD-612-3, AND CD-612-12.

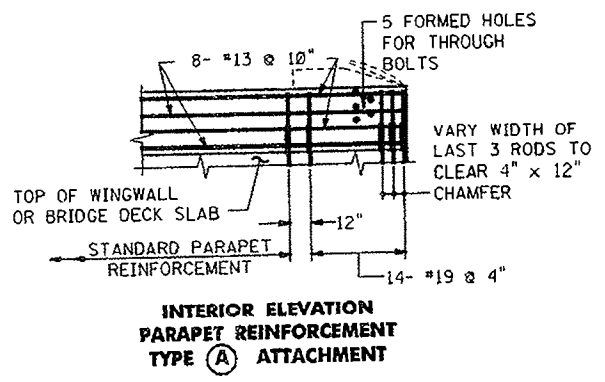
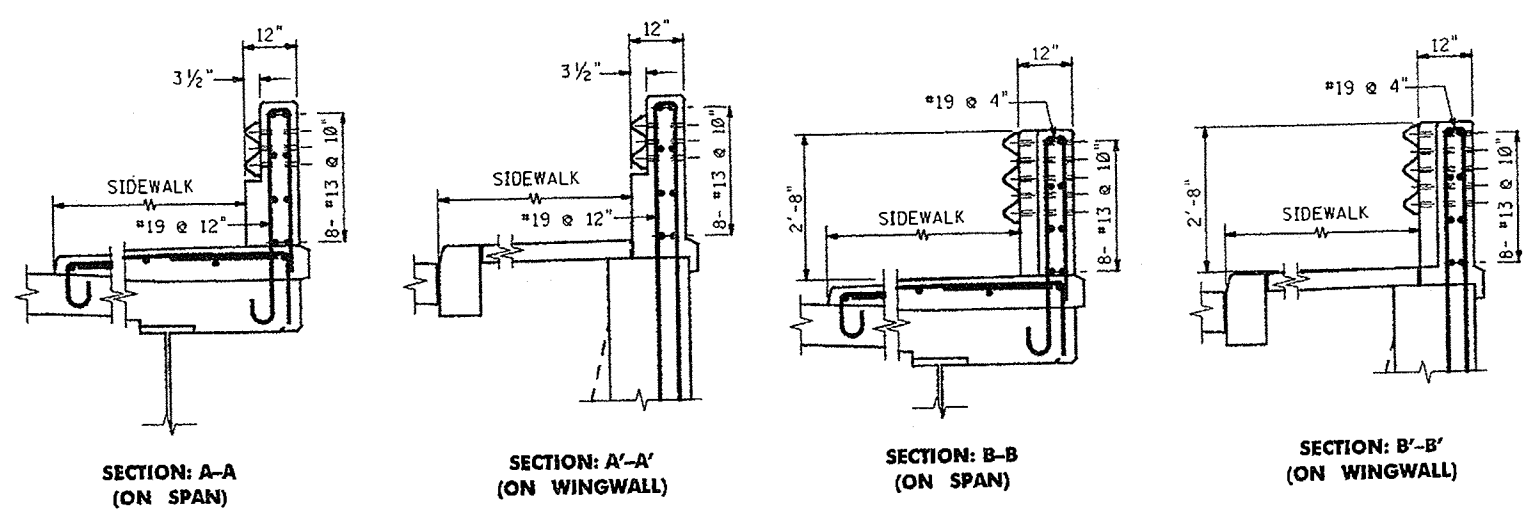
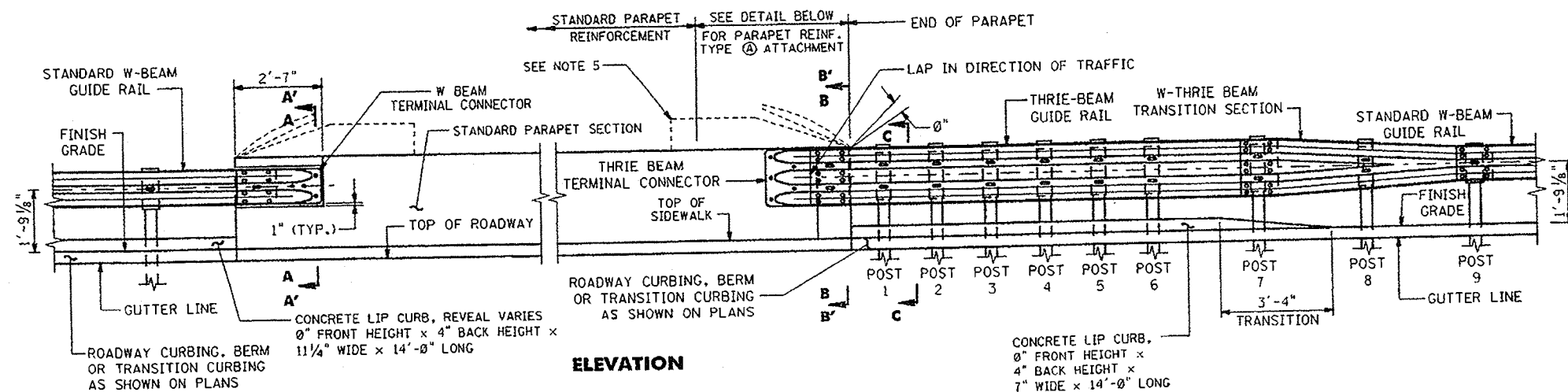

GUIDE RAIL ATTACHMENT - NEW CONSTRUCTION (SIDEWALK WITH PARAPET)

NOTE:
REINFORCING BARS ARE IN METRIC UNITS.

BEAM GUIDE RAIL ATTACHMENTS

N.T.S.

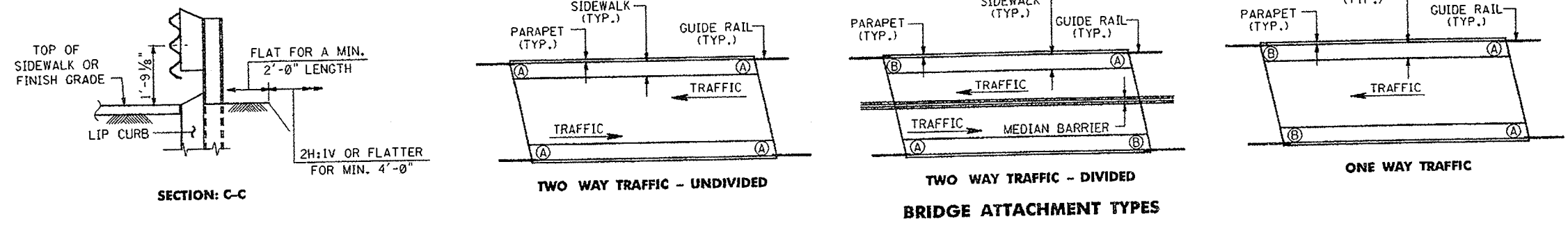

CD-612-15.1

CD-612-15

NEW JERSEY DEPARTMENT OF TRANSPORTATION

CONSTRUCTION DETAILS

57
129

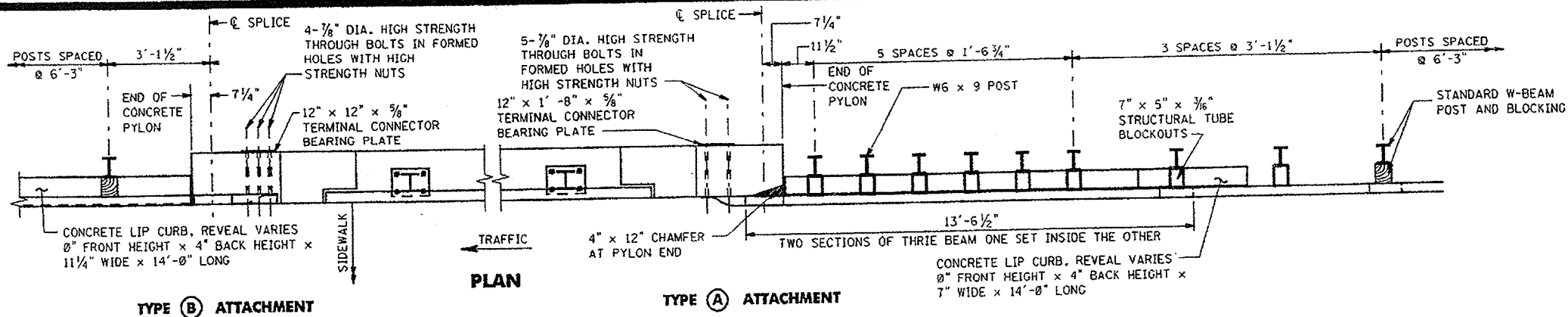

NOTES:

1. THIS GUIDE RAIL TRANSITION IS APPROPRIATE FOR CONNECTION TO A VERTICAL CONCRETE SHAPE.
2. FOR RECOMMENDED ATTACHMENT TYPE, REFER TO "BRIDGE ATTACHMENT TYPES", THIS SHEET.
3. ALL CROSS SLOPES BETWEEN THE PAVEMENT EDGE AND POSTS SHALL BE 10H:1V OR FLATTER.
4. EMBANKMENT MATERIAL CONFORMING TO THE NJDOT STANDARD SPECIFICATIONS SECTION 203 SHALL EXTEND FLAT BEHIND THE POSTS AT LEAST 2'-0" AT WHICH POINT A SLOPE OF NO STEEPER THAN 2H:1V SHOULD EXTEND A MINIMUM OF 4'-0" FURTHER.
5. CONCRETE PYLONS TO BE CONSTRUCTED AT ALL ENDS OF STEEL RAILING. ATTACH GUIDE RAIL TO THE PYLONS.
6. AT TYPE (A) ATTACHMENTS, THRIE BEAM RAIL ELEMENT WILL REQUIRE ADDITIONAL POST MOUNTING HOLES FOR POST #1, 3 & 5. CAUTION, HOLES ARE TO BE SHOP PUNCHED OR DRILLED BEFORE GALVANIZATION. NO FIELD DRILLING IS PERMITTED.
7. POSTS 1 THRU 7 SHALL BE 7'-2" LONG WITH 4'-10" POST EMBEDMENT. POST 8 SHALL BE 6'-8" LONG WITH 4'-6" POST EMBEDMENT. POST 9 SHALL BE 6'-8" LONG WITH 4'-4" POST EMBEDMENT.
8. LOCATE CONDUIT AT END OF PYLON SO AS NOT TO INTERFERE WITH GUIDE RAIL POST SPACING.
9. LOCATE DRAINAGE INLETS AND ELECTRIC JUNCTION BOXES ON APPROACHES SO AS NOT TO INTERFERE WITH GUIDE RAIL POST SPACING.
10. STRUCTURAL STEEL PLATES AND SHAPES SHALL CONFORM TO AASHTO M270 AND SHALL BE GALVANIZED AS PER AASHTO M111.
11. HIGH STRENGTH STEEL BOLTS, NUTS AND WASHERS SHALL CONFORM TO AASHTO M164. ZINC COATED BOLTS, NUTS AND WASHERS SHALL BE TREATED ACCORDING TO AASHTO M232M.
12. THE THICKNESS OF THRIE-BEAM, W-BEAM AND W-THRIE BEAM TRANSITION SHALL BE 12-GAUGE.
13. FOR ADDITIONAL THRIE BEAM AND W-BEAM DETAILS REFER TO CD-605-1.9, CD-612-1, CD-612-3, AND CD-612-12.

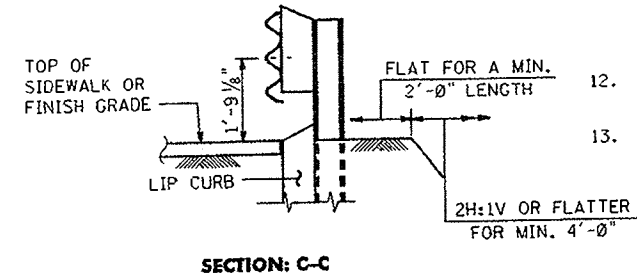
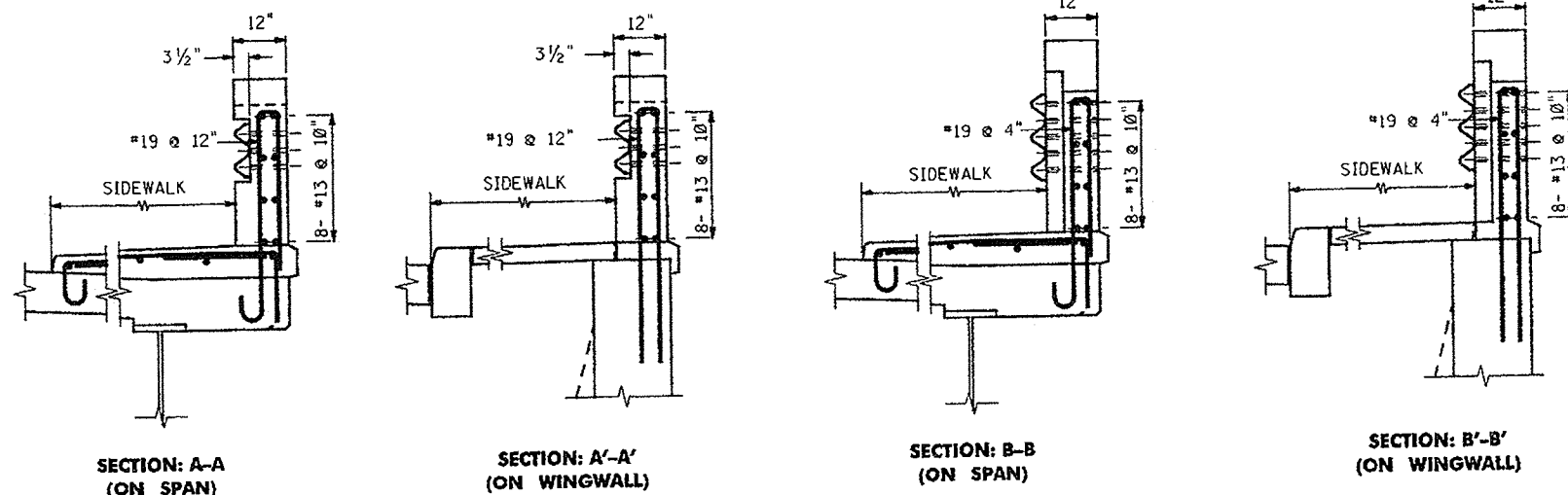
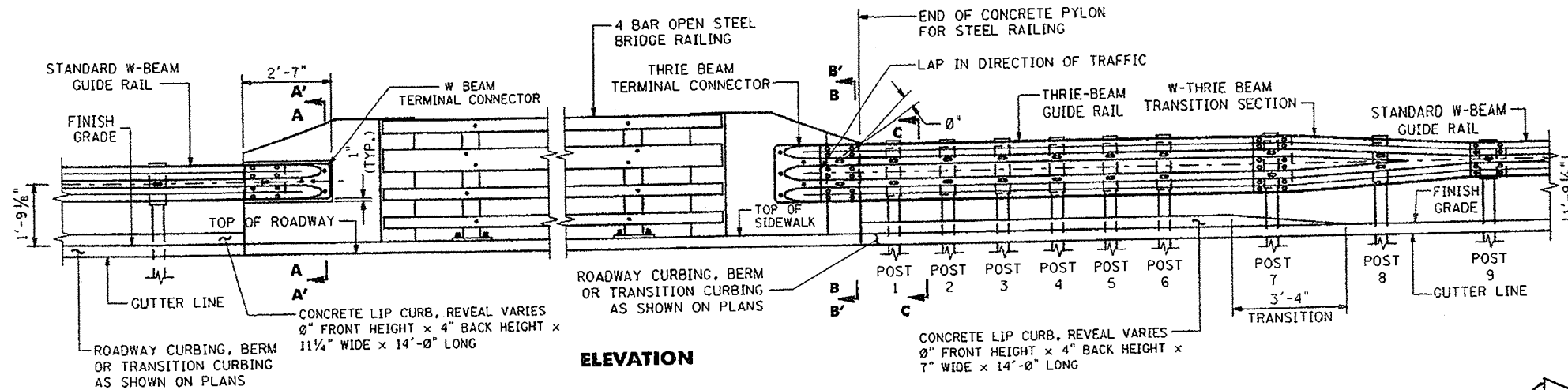

**GUIDE RAIL ATTACHMENT - NEW CONSTRUCTION
(SIDEWALK WITH STEEL RAILING)**

NOTE:
REINFORCING BARS ARE IN METRIC UNITS.

BEAM GUIDE RAIL ATTACHMENTS

N.T.S.

CD-612-16

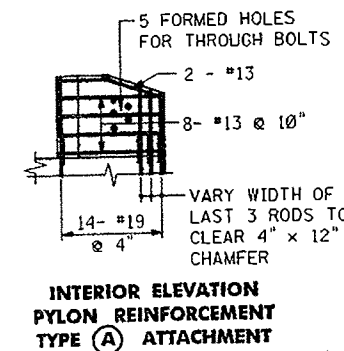
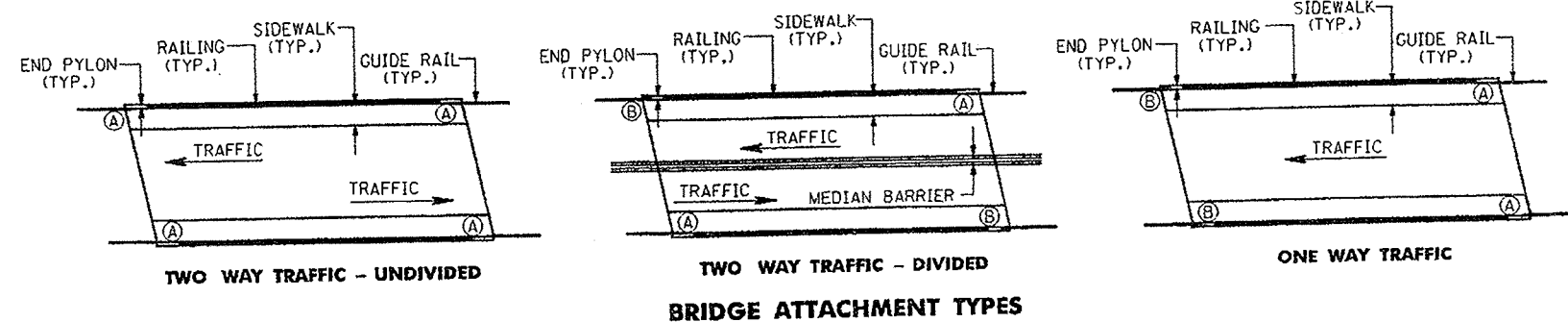

NEW JERSEY DEPARTMENT OF TRANSPORTATION

CONSTRUCTION DETAILS

CD-612-16.1

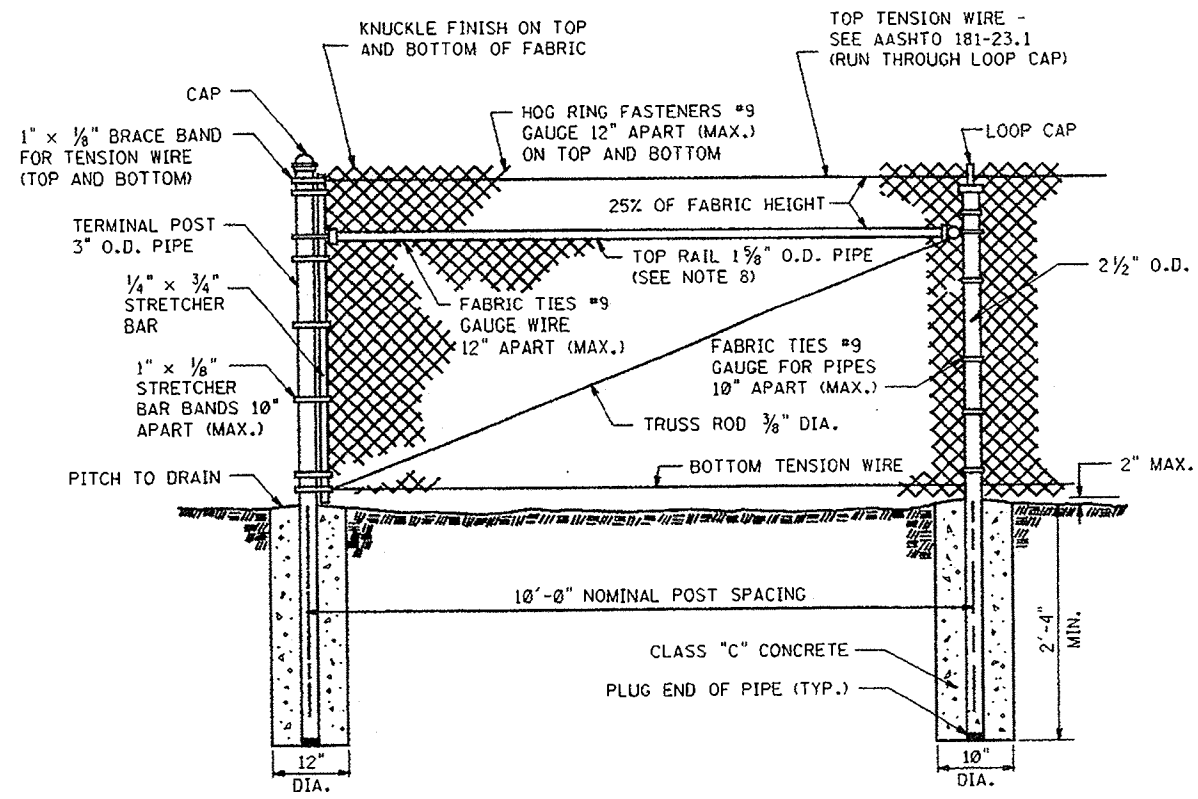

CHAIN-LINK FENCE, ___ ' HIGH

CD-614-1.1

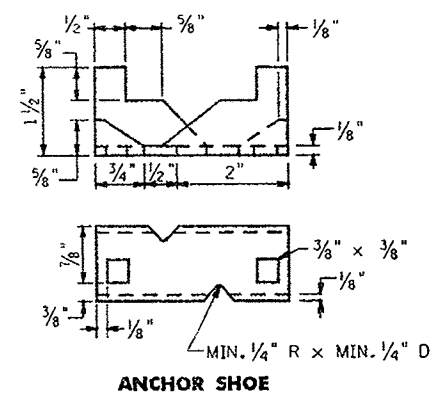

ANCHOR SHOE

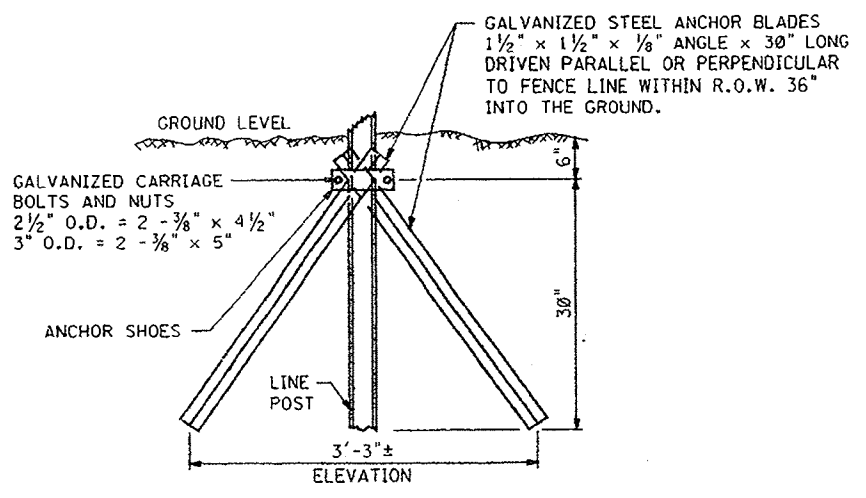

DRIVE ANCHOR SHOE ASSEMBLY

(SEE NOTE 7)

CD-614-1.2

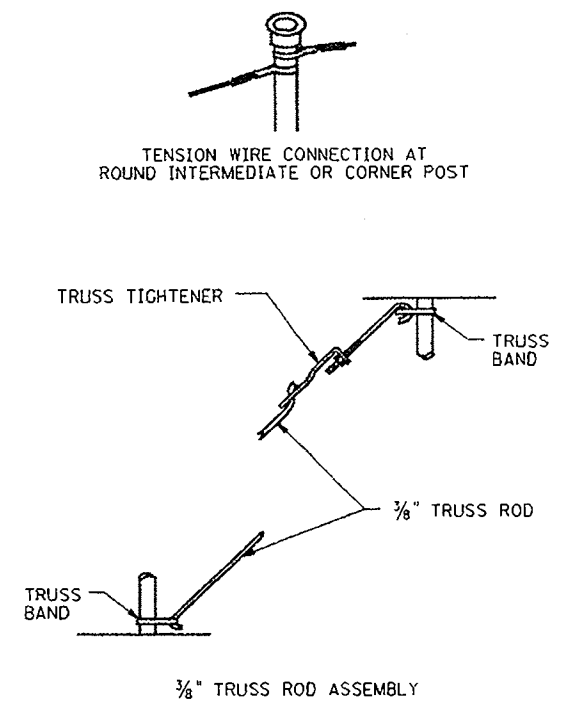

CHAIN-LINK FENCE ASSEMBLIES

CD-614-1.3

GENERAL NOTES

- CHAIN-LINK FENCE FABRIC, POSTS, RAILS, TIES, BANDS, BARS, RODS, AND OTHER FITTINGS AND HARDWARE SHALL CONFORM TO AASHTO M 181 FOR TYPES, GRADES AND CLASSES, AND AS NOTED BELOW.
- POSTS:

	TERMINAL, CORNER AND GATE POSTS	LINE POSTS	TOP OR BRACE RAIL
	3" O.D. PIPE	2 1/2" O.D. PIPE	1 5/8" O.D. PIPE
AASHTO TYPE	I OR II	I OR II	I OR II
AASHTO GRADE	1 OR 2	1 OR 2	1 OR 2
MINIMUM LENGTH OF POST FOR			
4' FABRIC	6'-8"	6'-8"	NA
5' FABRIC	7'-8"	7'-8"	NA
6' FABRIC	8'-8"	8'-8"	NA
ACTUAL OUTSIDE DIAMETER (IN.)	2.875	2.375	1.660
WALL THICKNESS (IN.)	GRADE 1 = .203 GRADE 2 = .160	GRADE 1 = .154 GRADE 2 = .120	GRADE 1 = .140 GRADE 2 = .111
- FABRIC:

TYPE II AND TYPE IV SHALL BE 9 GAUGE CORE WIRE, 2 INCH MESH
 TYPE IV FABRIC SHALL BE CLASS A OR B.
 TYPE IV FABRIC SHALL BE GREY IN COLOR, AND SHALL MATCH FEDERAL STANDARD 595A, COLOR CHIP NO. 26493 (SEMI-GLOSS), UNLESS OTHERWISE SPECIFIED IN THE SPECIAL PROVISIONS.
- THE CENTERLINE OF ALL POSTS SHALL NOT BE LESS THAN 8" INSIDE R.O.W.
- THE DEPTH OF CONCRETE FOOTINGS IN SOLID ROCK MAY BE REDUCED TO ONE FOOT BELOW THE TOP OF ROCK AND THE DIAMETER OF THE HOLE IN ROCK MAY BE REDUCED TO 3 1/2".
- BRACE BANDS AND STRETCHER BAR BANDS SHALL BE FURNISHED WITH 5/16" DIA. CARRIAGE BOLTS AND ELASTIC STOP NUTS.
- DRIVE ANCHOR SHOE ASSEMBLY ONLY TO BE USED IN WET AREAS AND WITH PRIOR APPROVAL OF THE ENGINEER.
- WHEN THE PLANS INDICATE A TERMINAL OR CORNER POST DESIGNATED TYPE "NR", THE TOP RAIL SHALL BE ELIMINATED FROM THIS SECTION OF FENCE.

CD-614-1.4

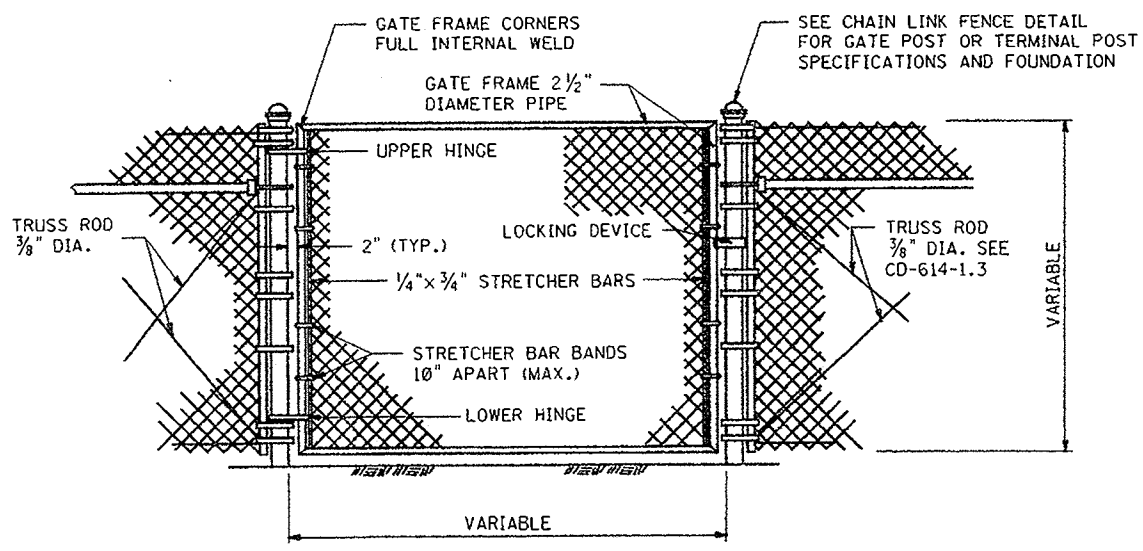

GATES, CHAIN-LINK FENCE, ___ ' WIDE

CD-614-1.5

CHAIN-LINK FENCE
N.T.S.

CD-614-1

NEW JERSEY DEPARTMENT OF TRANSPORTATION

CONSTRUCTION DETAILS

pen table = Audeyfeus2_ploretbbahalf-scaahb
 scale =
 queue =
 dots =
 file =
 ID =

PICKETS SHALL BE CEDAR, SPRUCE, MAPLE, OR OTHER WOOD SATISFACTORY TO THE ENGINEER AND FREE FROM LARGE KNOTS AND OTHER DEFECTS.

POSTS SHALL BE STEEL "U" SECTION WITH A MINIMUM OF 11 RIVETED LUGS, POSTS SHALL NOT BE LESS THAN 0.125" THICK OR WEIGH LESS THAN 2 POUNDS PER LINEAR FOOT.

5 GALVANIZED DOUBLE STAY CABLES SHALL RECEIVE NOT LESS THAN 4 TWISTS BETWEEN PICKETS AND ADJUSTED TO PREVENT PICKETS FROM SLIPPING THROUGH.

PICKETS SHALL BE 48" LONG, 1 1/2" WIDE, 1/2" THICK AND SPACED 2" APART.

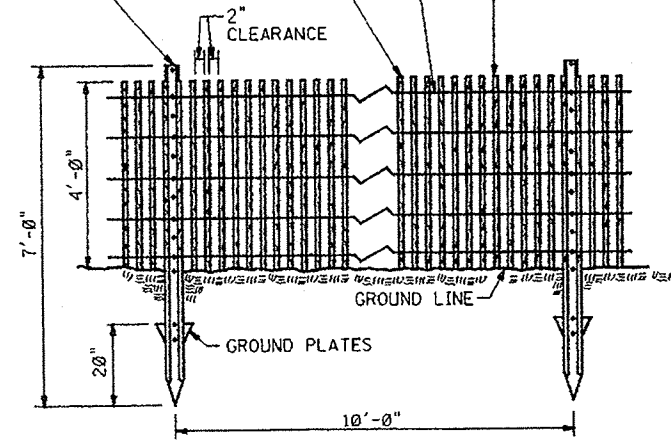

SNOW FENCE

CD-614-2.1

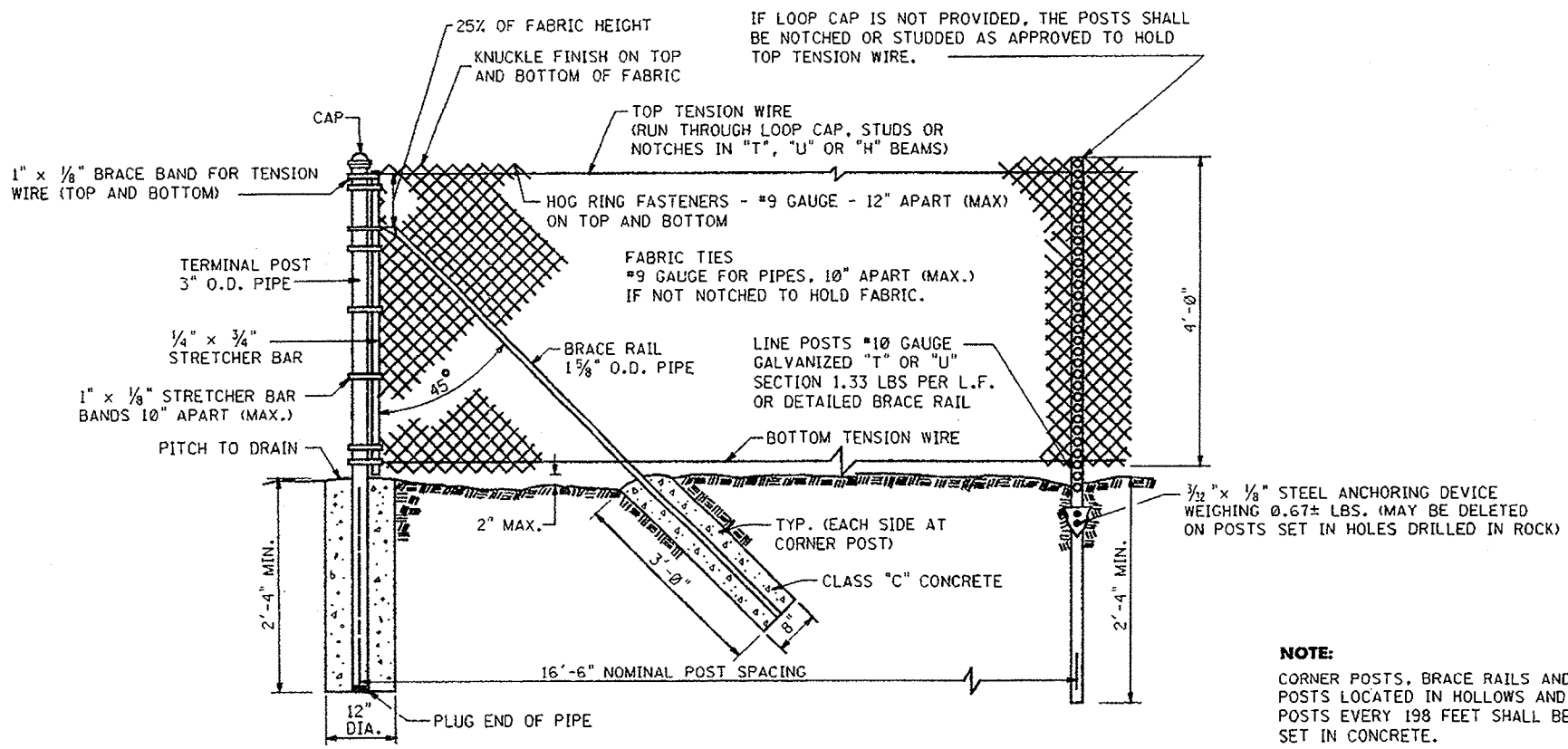

IF LOOP CAP IS NOT PROVIDED, THE POSTS SHALL BE NOTCHED OR STUDDED AS APPROVED TO HOLD TOP TENSION WIRE.

NOTE:
 CORNER POSTS, BRACE RAILS AND LINE POSTS LOCATED IN HOLLOWES AND LINE POSTS EVERY 198 FEET SHALL BE SET IN CONCRETE.

CHAIN-LINK FARM-TYPE FENCE

CD-614-2.2

POSTS SHALL BE STEEL "U" SECTION. POSTS SHALL NOT BE LESS THAN 0.125" THICK OR WEIGH LESS THAN 2 POUNDS PER LINEAR FOOT.

1" x 4" MESH OPENINGS

ALUMINUM WIRE FENCE TIES

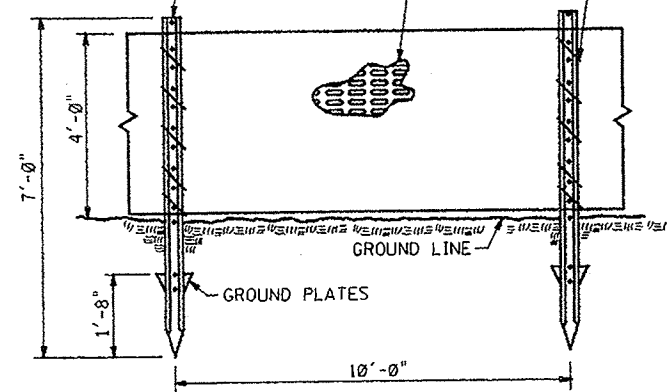

SNOW FENCE, PLASTIC

CD-614-2.3

CHAIN-LINK AND SNOW FENCE

N.T.S.

CD-614-2

NEW JERSEY DEPARTMENT OF TRANSPORTATION

CONSTRUCTION DETAILS

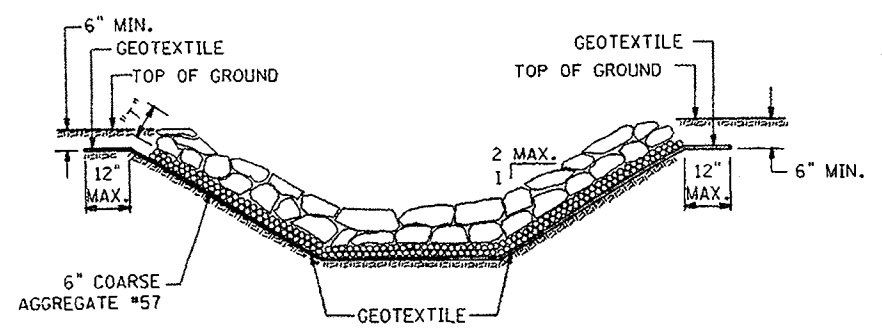

CHANNEL PROTECTION

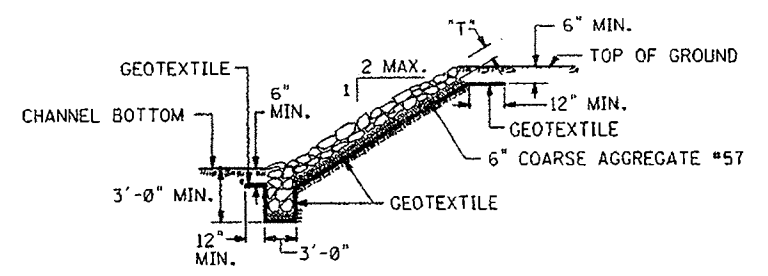

SLOPE PROTECTION

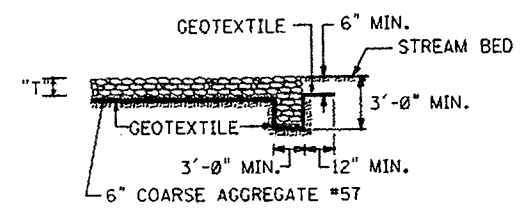

END TREATMENT FOR CHANNEL PROTECTION

NOTE:
FOR WIDTHS AND SLOPES
REFER TO CONSTRUCTION
PLANS

$T = 2d_{50}$
 d_{50} = DESIGNATED MEDIAN STONE SIZE, 6" MIN.

RIPRAP STONE CHANNEL /SLOPE TREATMENT

CD-616-1.1

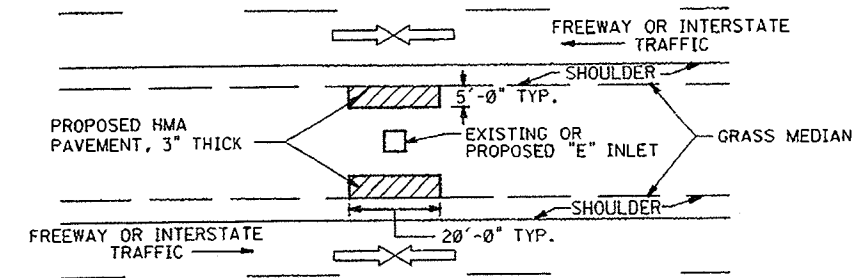

MEDIAN EDGE OF MAINLINE PAVEMENT

- NOTES:**
1. FOR SLOPES, REFER TO PLANS.
 2. WHERE GUIDE RAIL EXISTS AT THE LOW POINT, THE PROPOSED HMA CONCRETE PAVEMENT HAS PREFERENCE OVER NON-VEGETATIVE SURFACE.
 3. HMA PAVEMENT SHALL BE THE SAME AS THE SURFACE COURSE. IF THERE IS NO SURFACE COURSE, I-5, WITH 3 INCH MINIMUM THICKNESS, SHALL BE USED.
 4. IN CUT SECTIONS THE HMA CONCRETE PAVEMENT SHALL BE GRADED TO DRAIN TOWARD THE INLET.
 5. THE RIPRAP AND GEOTEXTILE MATERIALS SHALL BE PAID FOR UNDER THE ITEM RIPRAP STONE SLOPE PROTECTION, ___" THICK, (D50 = ___").

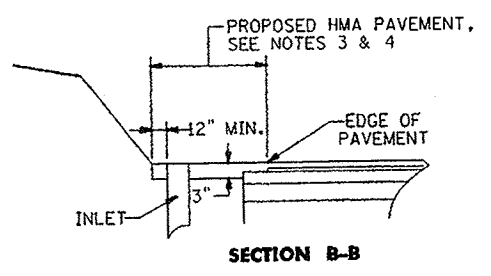

SECTION B-B

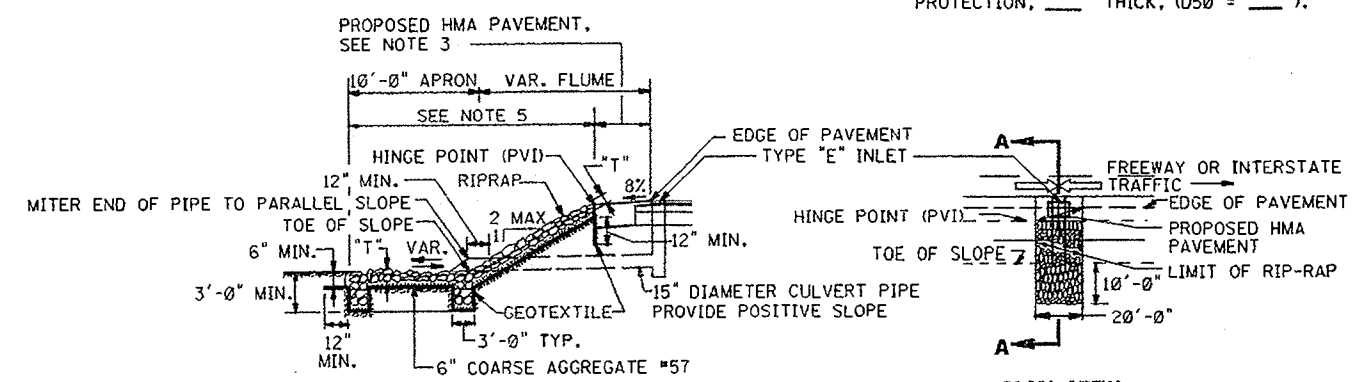

SECTION A-A

PLAN VIEW

$T = 2d_{50}$
 d_{50} = DESIGNATED MEDIAN STONE SIZE (8" MIN")

EDGE OF RAMP OR OUTSIDE EDGE OF MAINLINE PAVEMENT IN CUT

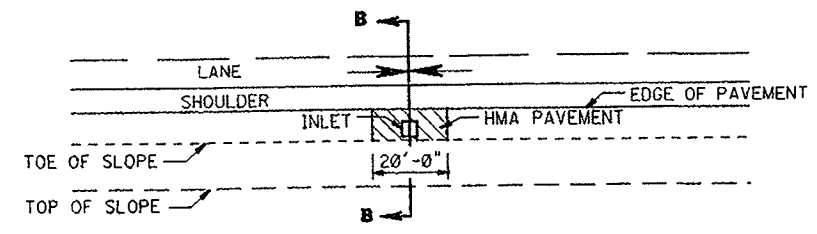

EDGE OF RAMP OR OUTSIDE EDGE OF MAINLINE PAVEMENT IN CUT

SLOPE TREATMENT AT LOW POINTS OF UMBRELLA SECTIONS

SLOPE AND CHANNEL PROTECTION

N.T.S.
HMA = HOT ASPHALT MIX

CD-616-1

NEW JERSEY DEPARTMENT OF TRANSPORTATION

CONSTRUCTION DETAILS

CD-616-1.2

DRUMS SHALL BE MADE OF ORANGE PLASTIC WITH A MINIMUM OF FOUR ALTERNATE ORANGE AND SILVER (WHITE) REFLECTORIZED STRIPES. IF THERE ARE NON-REFLECTORIZED SPACES BETWEEN THE STRIPES, THEY SHALL BE NO MORE THAN 2" WIDE. STRIPES SHALL BE REFLECTIVE SHEETING, TYPE III-B. THE TOP OF THE DRUM SHALL NOT BE OPEN. DRUMS SHALL BE CONSTRUCTED TO INHIBIT ROLLING IF KNOCKED OVER. THE REFLECTORIZED AREA OF THE DRUMS SHALL BE ROUND EXCEPT THAT OTHER SHAPES, WHICH PROVIDE THE SAME VISIBILITY AS A 18" DIAMETER ROUND DRUM REGARDLESS OF ORIENTATION, MAY BE USED IF APPROVED BY THE BUREAU OF MATERIALS.

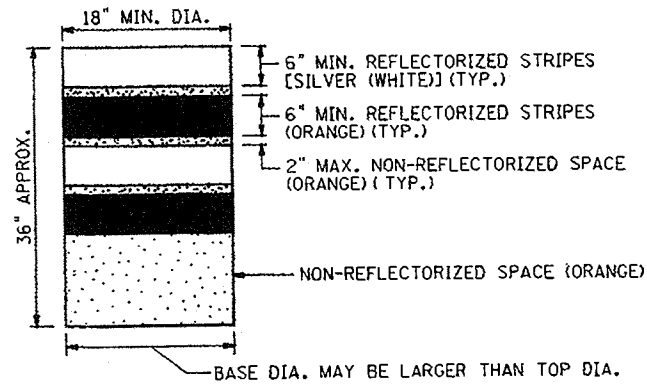

WHEN BALLAST IS REQUIRED BY THE ENGINEER, SAND SHALL BE USED. THE MAXIMUM WEIGHT OF THE BALLAST SHALL BE 50 LBS. AND BE LOCATED APPROXIMATELY AT GROUND LEVEL.

DRUMS

CD-617-1.1

NOTES:

TRAFFIC CONES SHALL BE PREDOMINATELY ORANGE IN COLOR.

BASES MAY BE OF BREAKAWAY BALLASTED TYPE.

MINOR MANUFACTURER'S VARIATIONS MAY BE ACCEPTABLE UPON APPROVAL OF THE ENGINEER.

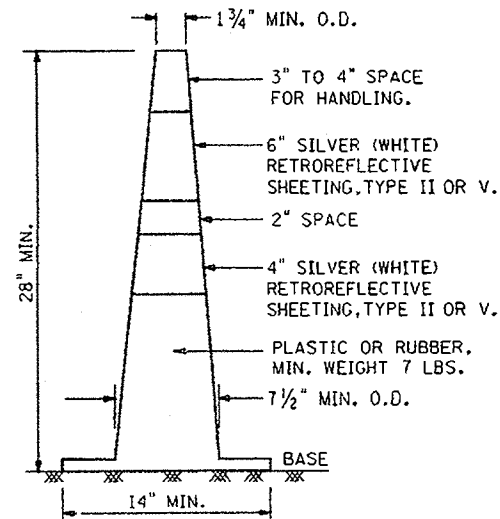

TRAFFIC CONES

CD-617-1.2

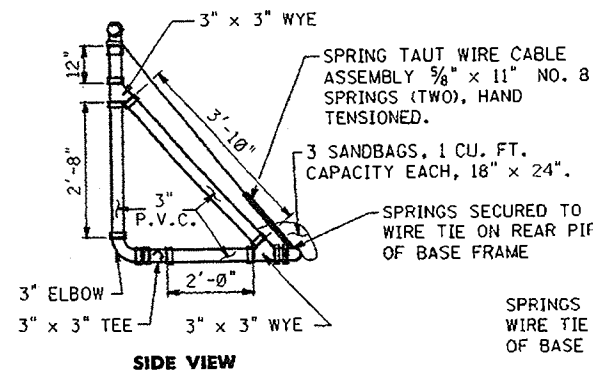

SIDE VIEW

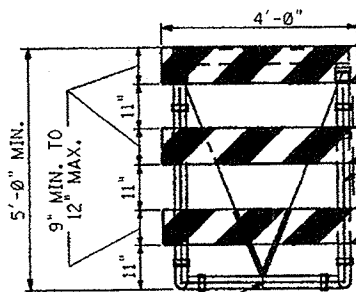

FRONT VIEW

SPRINGS SECURED TO WIRE TIE ON REAR PIPE OF BASE FRAME

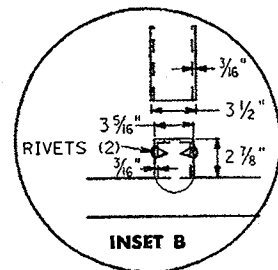

INSET B

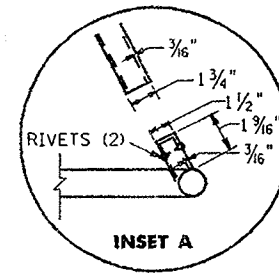
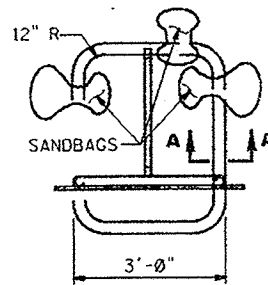

INSET A

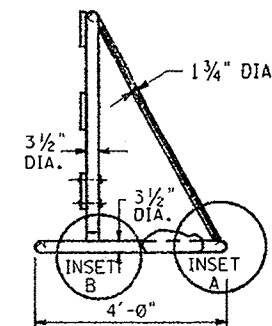
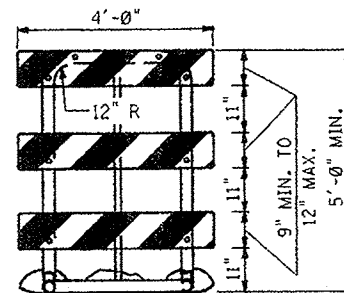

THE BASE AND UPRIGHT SHALL BE 3 1/2" DIA. ROTATIONALLY MOLDED POLYETHYLENE PLASTIC CONFORMING TO ASTM D 1248-II A3-E4. THE BRACE SHALL BE 1 3/4" DIA. EXTRUDED POLYETHYLENE PLASTIC CONFORMING TO ASTM D 1248-III A4. POLYETHYLENE PLASTIC SHALL BE WHITE AND SHALL BE ULTRAVIOLET LIGHT STABILIZED, ASTM D746.

TYPE III, PE

BREAKAWAY BARRICADES

NOTES:

1. THE 9" MIN. x 48", OR 12" MAX. x 48" BARRICADE RAILS SHALL BE FABRICATED FROM 0.024" ANODIZED ALUMINUM OR 0.125" MAX. PLASTIC SHEETING AND SHALL BE ATTACHED, 4 PER RAIL, WITH 1 INCH NO. 14 PAN HEAD METAL SCREWS OR PLASTIC RIVETS. ALL CORNERS SHALL BE ROUNDED.
2. ORANGE AND SILVER (WHITE) STRIPES SHALL BE RETROREFLECTIVE SHEETING, TYPE II OR III-A, AS SHOWN FOR CONSTRUCTION SIGNS. ALTERNATE ORANGE AND SILVER (WHITE) STRIPES 6" WIDE SLOPING DOWNWARD AT AN ANGLE OF 45 DEGREES IN THE DIRECTION TRAFFIC IS TO PASS.
3. THE 18" x 24" SANDBAGS SHALL BE FABRICATED FROM POLYPROPYLENE AND SHALL BE FILLED WITH 1 CUBIC FOOT OF SAND. PLACEMENT OF SANDBAGS SHALL BE AS SHOWN ABOVE.
4. SANDBAG PLACEMENT MAY BE ADJUSTED AT THE DIRECTION OF THE ENGINEER. ALL DIMENSIONS ON FULL PIPE LENGTH.
5. EITHER TYPE III, PE OR TYPE III, PVC CAN BE USED AT THE OPTION OF THE CONTRACTOR.

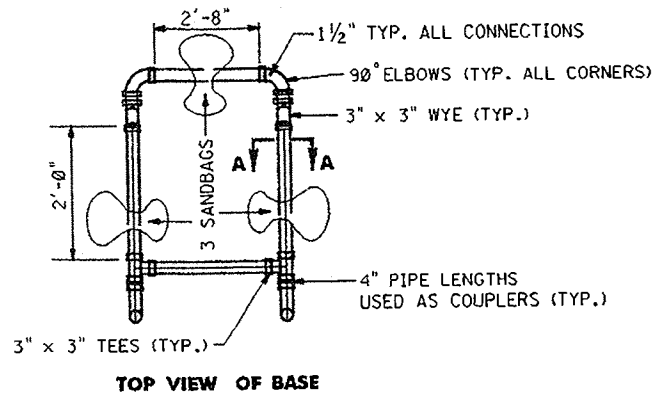

TOP VIEW OF BASE

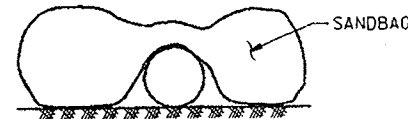

SECTION A-A

PIPE SHALL BE WHITE PVC SCHEDULE 40 ASTM D 1785 OR PVC, SDR-26 ASTM D 2241. FITTINGS SHALL BE WHITE PVC OR ABS OF MATCHING WALL THICKNESS AND INSIDE DIAMETER AND MEETING THE MATERIALS, REQUIREMENTS AND TESTING SECTIONS OF ASTM D 2466 FOR PVC AND ASTM D 2468 FOR ABS. ALL JOINTS SHALL BE SLIP FIT AND NOT THREADED OR CEMENTED. PVC FITTINGS MEETING ASTM D 2665 WILL ALSO BE ACCEPTABLE. PVC OR ABS MATERIAL SHALL BE ULTRAVIOLET LIGHT STABILIZED.

TYPE III, PVC

TRAFFIC CONTROL DEVICES
N.T.S.

CD-617-1

NEW JERSEY DEPARTMENT OF TRANSPORTATION

CONSTRUCTION DETAILS

CD-617-1.3

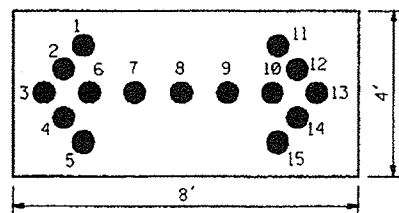

4' x 8' BOARD
FLASHING MESSAGES TO LIGHT AS FOLLOWS

RIGHT ARROW	3,6,7,8,9,11,12,13,14 & 15
LEFT ARROW	1,2,3,4,5,7,8,9,10 & 13
DOUBLE ARROW	1,2,3,4,5,7,8,9,11,12,13,14 & 15
CAUTION MODE	3,6,7,8,9,10 & 13 OR 1,5,11 & 15

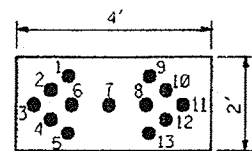

2' x 4' BOARD

RIGHT ARROW	3,6,7,9,10,11,12 & 13
LEFT ARROW	1,2,3,4,5,7,8 & 11
DOUBLE ARROW	1,2,3,4,5,7,9,10,11,12 & 13
CAUTION MODE	3,6,7,8,9,10 & 11 OR 1,5,9 & 13

ILLUMINATED FLASHING ARROWS,

CD-617-2.1



NOTE:
SIGN FACES SHALL BE RETROREFLECTIVE SHEETING, TYPE II, OR III-A.

STOP / SLOW PADDLE

CD-617-2.4

DELINEATOR GUIDE POSTS SHALL BE PREDOMINATELY ORANGE IN COLOR.

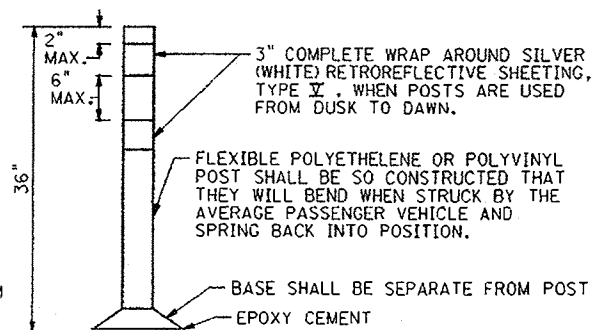

THE BASE SHALL BE REMOVED FROM THE PAVEMENT WHEN THE POST IS NO LONGER NEEDED.

NOTE:
MINOR MANUFACTURER'S VARIATIONS MAY BE ACCEPTABLE UPON APPROVAL OF THE ENGINEER.

DELINEATOR GUIDE POSTS

CD-617-2.2

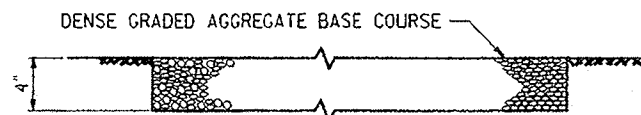

NOTE:
ALL EXCAVATION OR EMBANKMENT REQUIRED TO CONSTRUCT TEMPORARY SIDEWALK SHALL BE INCLUDED IN UNIT PRICE BID FOR PAY ITEM, TEMPORARY SIDEWALK.

TEMPORARY SIDEWALK

CD-617-2.5

ALTERNATE ORANGE AND SILVER (WHITE) STRIPES SHALL BE RETROREFLECTIVE SHEETING, TYPE II, OR III-A, 6" WIDE SLOPING DOWNWARD AT AN ANGLE OF 45° IN THE DIRECTION TRAFFIC IS TO PASS.

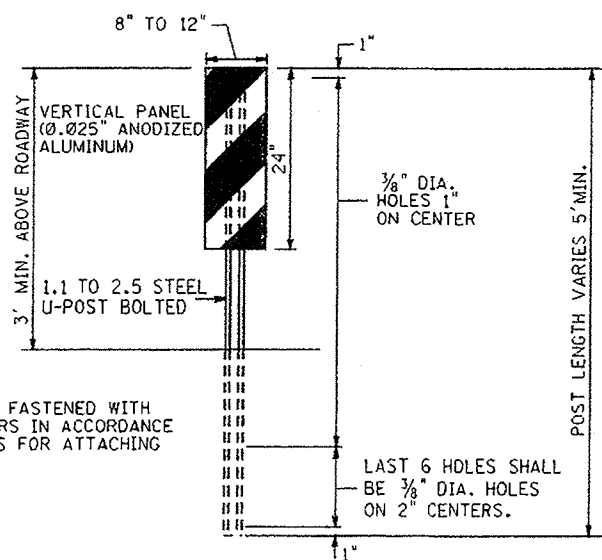

PANELS TO BE SECURELY FASTENED WITH BOLTS, NUTS AND WASHERS IN ACCORDANCE WITH THE SPECIFICATIONS FOR ATTACHING SIGNS TO U-POSTS.

NOTE:
MINOR MANUFACTURER'S VARIATIONS MAY BE ACCEPTABLE UPON APPROVAL OF THE ENGINEER.

VERTICAL PANELS

CD-617-2.3

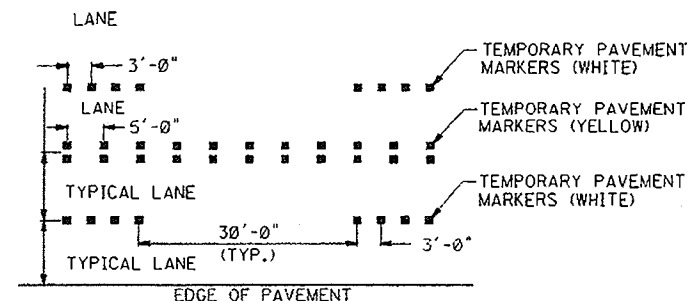

NOTES:

- WHEN TEMPORARY PAVEMENT MARKERS ARE TO SIMULATE LANE LINES ON SHARP CURVES OR IN TRANSITIONS TO EITHER REDUCE THE NUMBER OF LANES OR TO SHIFT TRAFFIC LATERALLY, THE TEMPORARY PAVEMENT MARKERS SHALL BE SPACED 5 FEET APART CONTINUOUSLY THROUGH THE CURVE OR TRANSITION AREA.
- TEMPORARY PAVEMENT MARKERS SHOULD NOT BE USED TO DELINEATE RIGHT EDGE LINES.

TEMPORARY PAVEMENT MARKERS

CD-617-2.6

TRAFFIC CONTROL DEVICES AND DETAILS

N.T.S.

CD-617-2

NEW JERSEY DEPARTMENT OF TRANSPORTATION

CONSTRUCTION DETAILS

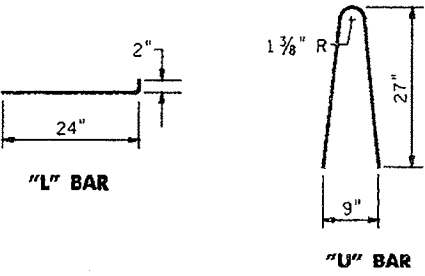
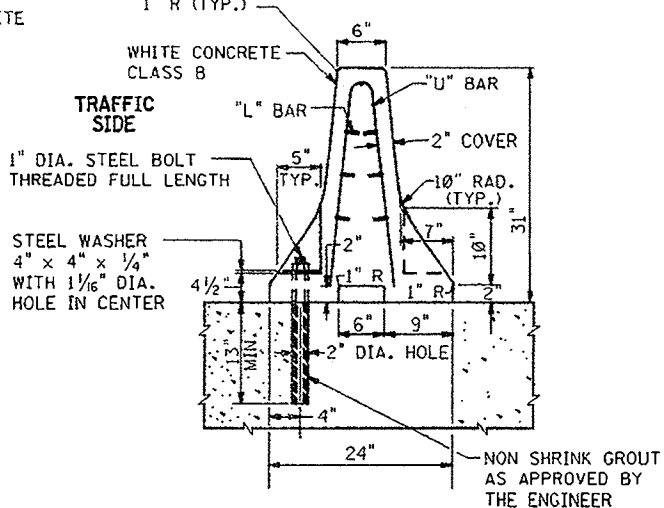
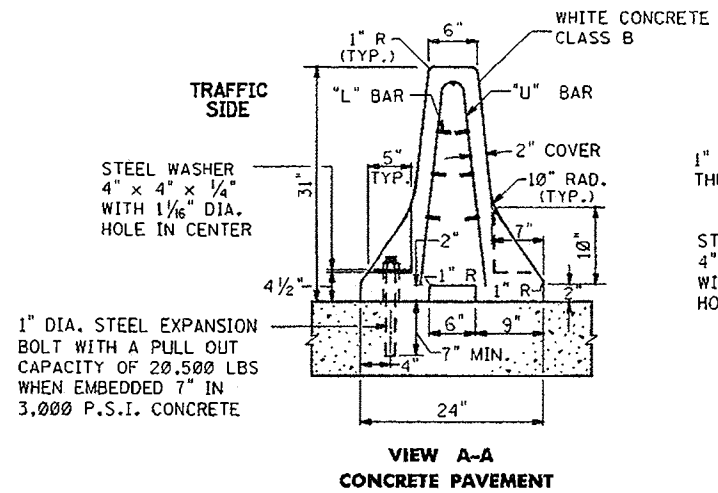
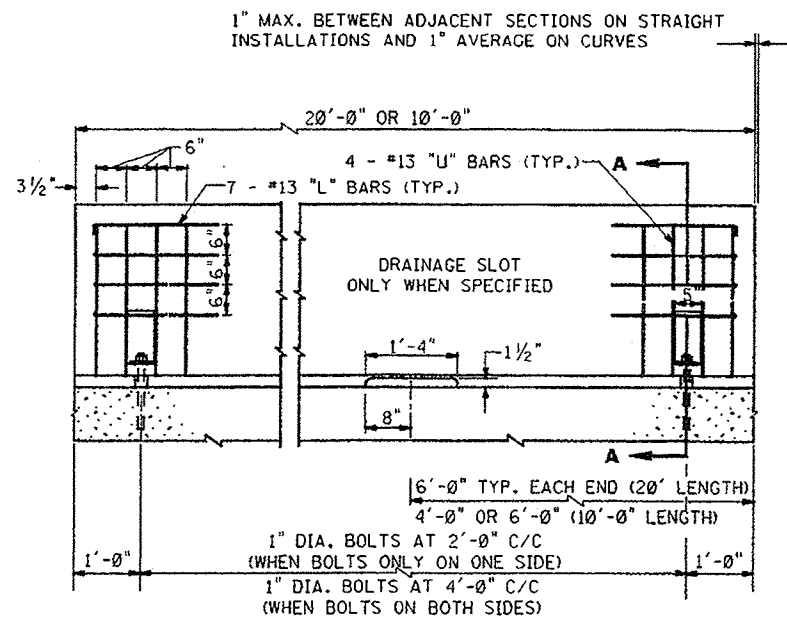

PRECAST CONCRETE CURB, CONSTRUCTION BARRIER, TYPE 1

- NOTES:**
- THE APPROACH END OF THE PRECAST CONCRETE CURB, CONSTRUCTION BARRIER SHOULD BE FLARED AWAY FROM TRAFFIC AT A RATE OF 20:1. WHERE POSTED SPEEDS ARE LESS THAN 50 M.P.H., A FLARE RATE OF 15:1 MAY BE USED. ON CURVED ROADWAYS, KINKS IN THE BARRIER ALIGNMENT SHOULD BE AVOIDED.
 - REINFORCING SHOWN IS THE MINIMUM REQUIRED. ADDITIONAL REINFORCING NECESSARY FOR HANDLING SHALL BE THE OPTION AND RESPONSIBILITY OF THE CONTRACTOR.
 - IF TRAFFIC WILL BE ON BOTH SIDES OF THE BARRIER, THE CONTRACTOR SHALL PROVIDE BOLT RECESSES SO THE BOLTS CAN BE INSTALLED AT 4 FEET C. TO C. ON EACH SIDE. AT THE OPTION OF THE CONTRACTOR, BOLT RECESSES AND BOLTS MAY BE PROVIDED AT 4 FEET C. TO C. ON EACH SIDE WHEN TRAFFIC IS ONLY ON ONE SIDE OF THE BARRIER.
 - WHEN THE BARRIER HAS BEEN REMOVED, THE BOLTS SHALL BE REMOVED OR CUT OFF TO A LEVEL OF 1/2" MINIMUM BELOW THE PAVEMENT SURFACE AND THE HOLES SHALL BE FILLED TO THE SATISFACTION OF THE ENGINEER.
 - BOLTS, OTHER THAN EXPANSION BOLTS, SHALL BE THREADED RODS MADE FROM ASTM GRADE 250 STEEL. NUTS SHALL CONFORM TO ASTM A 307.
 - VARIATIONS TO THE DETAILS SHALL BE SUBJECT TO APPROVAL.
 - FOR INSTALLATION ON BRIDGE DECKS, REFER TO BRIDGE PLANS FOR NECESSARY MODIFICATIONS, AS REQUIRED.
 - REINFORCEMENT STEEL SHALL CONFORM TO SUBSECTION 915.01 A, DEFORMED BARS.

CD-617-3.1

- NOTES:**
- BOLTS AND NUTS SHALL CONFORM TO ASTM A 307.
 - BOLTS SHALL BE REQUIRED IN EVERY ANCHOR POCKET HOLE.
 - CONNECTION KEY SHALL BE USED WITH TYPE 1 APPLICATION.
 - WHEN BARRIER HAS BEEN REMOVED, THE BOLTS SHALL BE REMOVED OR CUT OFF TO A LEVEL OF 1/2" MINIMUM BELOW THE SURFACE AND THE HOLE FILLED TO THE SATISFACTION OF THE ENGINEER.

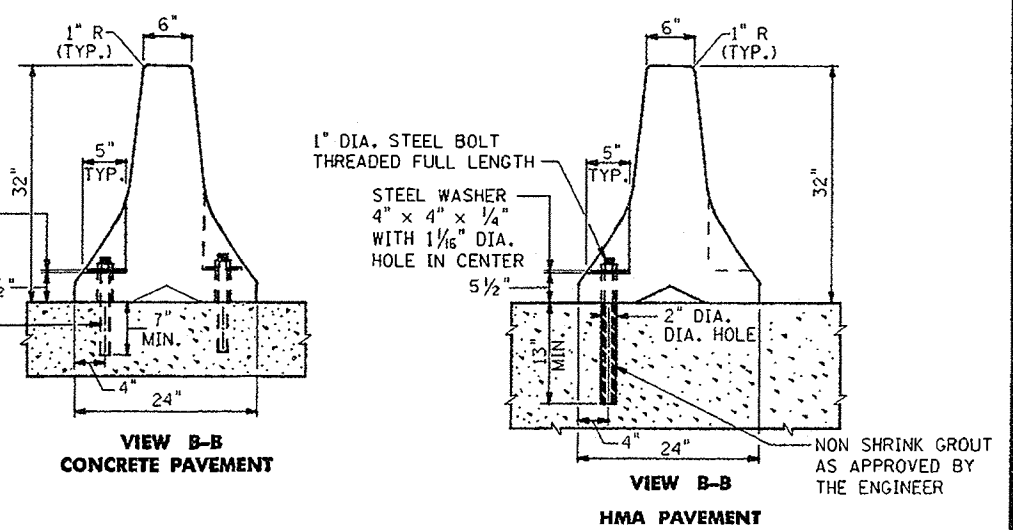
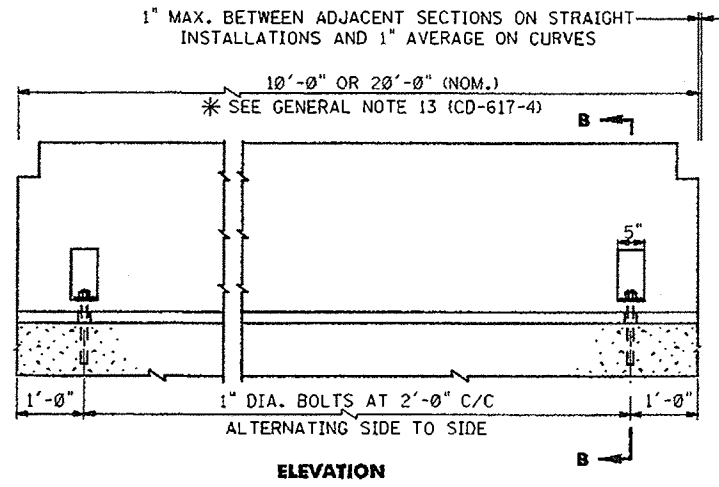

ANCHORAGE FOR TYPE 4 BARRIER USED AS TYPE 1

CD-617-3.2

- NOTES:**
- REINFORCING BARS ARE IN METRIC UNITS.
 - HMA = HOT ASPHALT MIX

PRECAST CONCRETE CURB, CONSTRUCTION BARRIER, TYPE 1
N.T.S.

CD-617-3

NEW JERSEY DEPARTMENT OF TRANSPORTATION

CONSTRUCTION DETAILS

PRECAST CONCRETE CURB, CONSTRUCTION BARRIER JOINT CONNECTION DETAILS

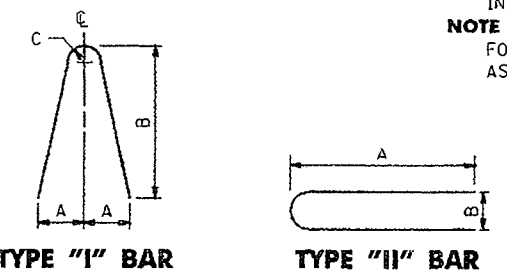
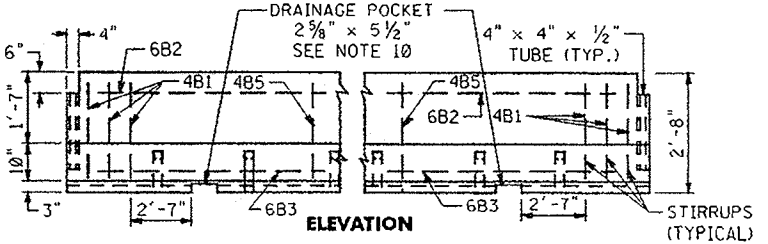
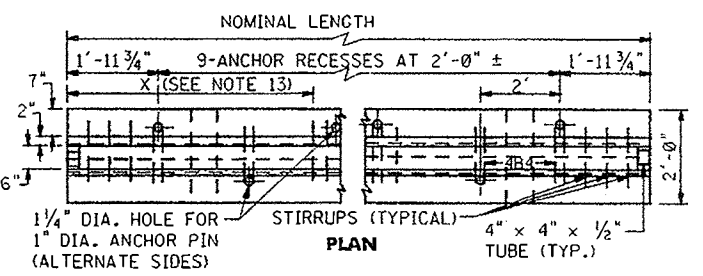
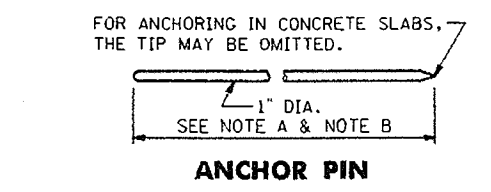
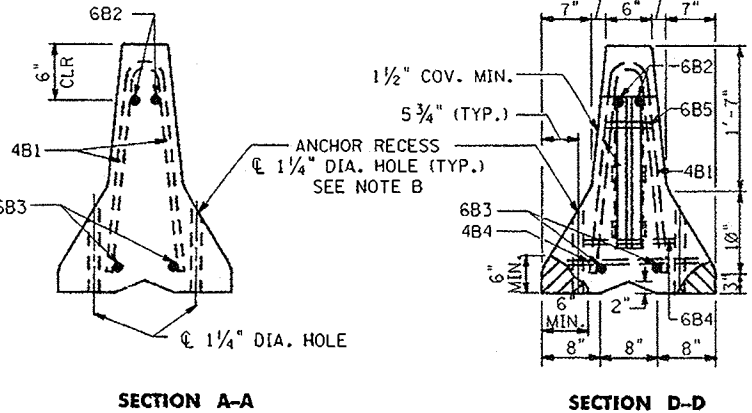
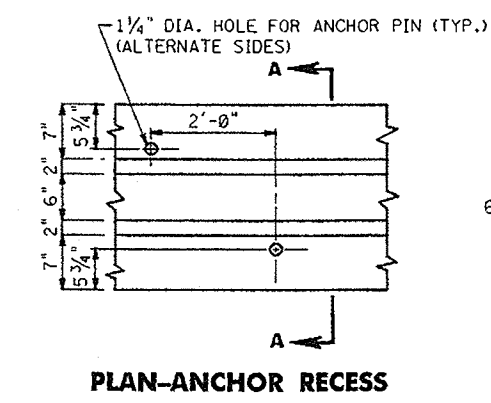
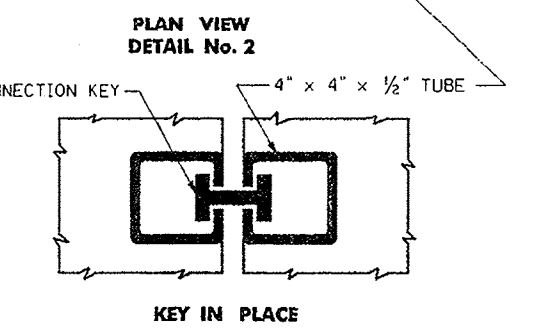
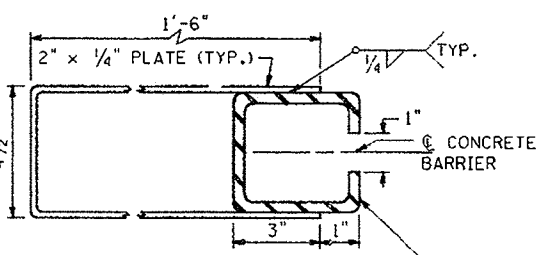
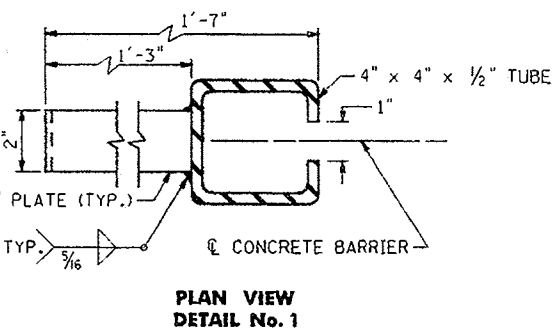
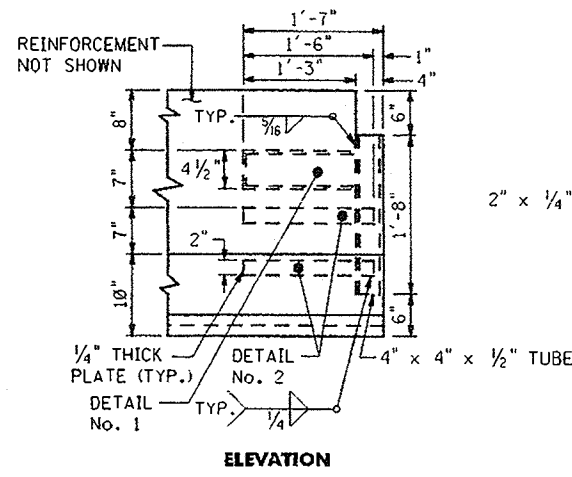
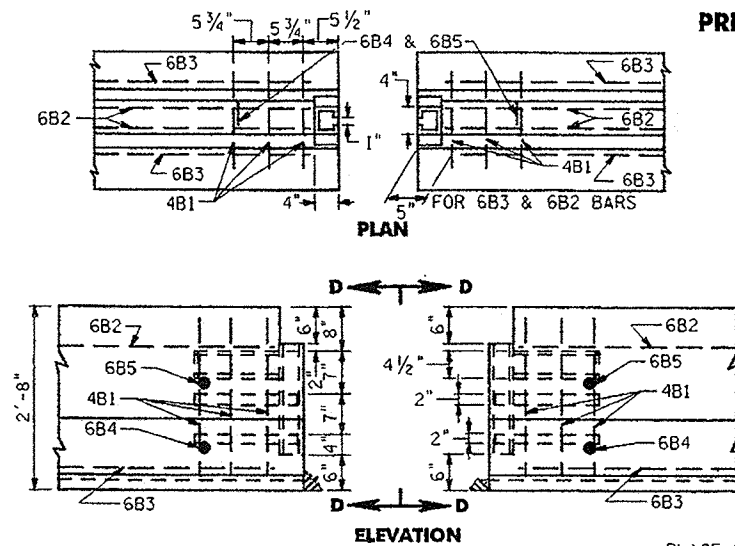

JOINT CLASS	TABLE OF JOINT AND ANCHORAGE TREATMENTS FOR TYPE 4 APPLICATIONS ONLY
	JOINT TREATMENT
A	CONNECTION KEY ONLY
B	CONNECTION KEY AND GROUT IN EVERY JOINT
C	CONNECTION KEY AND GROUT IN EVERY JOINT AND PIN EVERY OTHER UNIT. IN UNITS THAT ARE TO BE ANCHORED, PINS SHALL BE REQUIRED IN EVERY ANCHOR PIN RECESS

TABLE OF VARIABLE BARS			
NOMINAL LENGTH OF BARRIER UNIT	MARK	"X"	NO. EACH SECTION
20'	4B4	N.A.	9
20'	4B5	6'-11"	2
18'	4B4	N.A.	8
18'	4B5	6'-5"	2
16'	4B4	N.A.	7
16'	4B5	5'-11"	2
14'	4B4	N.A.	6
14'	4B5	7'-0"	1
12'	4B4	N.A.	5
12'	4B5	6'-0"	1
10'	4B4	N.A.	4
10'	4B5	5'-0"	1
8'	4B4	N.A.	3
8'	4B5	-	0

"X" DISTANCE FROM END OF BARRIER TO 4B5 BAR

BARS LIST (EACH BARRIER SECTION)								
MARK	SIZE	NUMBER IN EACH SECTION	LENGTH	TYPE	A	B	C	LOCATION
4B1	#13	6	4'-11"	I	5"	26"	2"	STIRRUPS
4B4	#13	SEE NOTE 13	3'-1"	II	15 1/2"	4"		STIRRUPS
4B5	#13	SEE NOTE 13	4'-11"	I	5"	26"	2"	STIRRUPS
6B2	#19	2	SEE NOTE 13	STR.				LONGITUDINAL (TOP) NORMAL SECTION
6B3	#19	2	SEE NOTE 13	STR.				LONGITUDINAL (BOTTOM) NORMAL SECTION
6B4	#19	2	1'-2"	STR.				TRANSVERSE (BOTTOM) NORMAL SECTION
6B5	#19	2	0'-6"	STR.				TRANSVERSE (TOP) NORMAL SECTION

- GENERAL NOTES:**
- STEEL PLATE SHALL BE ASTM A36, A588, A441 OR A572 GRADE 50.
 - REINFORCING BARS SHALL BE ASTM A615, GRADE 60.
 - CONCRETE SHALL BE WHITE CONCRETE CLASS B.
 - CONCRETE CLEAR COVER FOR REINFORCING BARS SHALL BE 1 1/2" (MIN.).
 - A MINIMUM OF (2) TWO RECESSED LIFTING DEVICES SHALL BE USED ON EACH SECTION. EACH LIFTING DEVICE SHALL HAVE A MINIMUM CAPACITY OF 6 TONS.
 - TUBE STEEL SHALL BE ASTM A500, GRADE B OR C.
 - ANCHOR PINS SHALL BE 1 INCH DIA. ASTM A36.
 - ANCHOR PINS ARE NOT REQUIRED IN EVERY UNIT. SEE TABLE OF JOINT TREATMENTS.
 - ALL END SECTIONS SHALL BE PINNED UNLESS OTHERWISE NOTED.
 - 2 5/8" X 5 1/2" DRAINAGE POCKETS - TWO REQUIRED IN SECTIONS 12 FEET AND GREATER. ONE REQUIRED IN 8 FOOT AND 10 FOOT SECTIONS.
 - AFTER A BARRIER UNIT HAS BEEN PLACED AND THE CONNECTION KEY INSERTED, REMOVE ANY SLACK IN THE JOINT BY PULLING THE UNIT IN A DIRECTION PARALLEL TO IT'S LONGITUDINAL AXIS.
 - THE PRECAST CONCRETE CURB, CONSTRUCTION BARRIER SHALL BE CAST IN STEEL FORMS.
 - THE PRECAST CONCRETE CURB SHALL BE UNITS OF 20 FEET, HOWEVER, OTHER LENGTHS MAY BE USED TO MEET FIELD CONDITIONS. THE NUMBER AND PLACEMENT OF THE 4B4 AND 4B5 BARS WILL VARY WITH THE LENGTH OF THE BARRIER UNIT AS SHOWN ON THE TABLE OF VARIABLE BARS. THE 6B2 AND 6B3 BARS SHALL BE 10 INCHES SHORTER THAN THE NOMINAL LENGTH OF THE BARRIER UNITS.
 - REINFORCING SHOWN IS THE MINIMUM REQUIRED. ADDITIONAL REINFORCING NECESSARY FOR HANDLING SHALL BE THE OPTION AND RESPONSIBILITY OF THE CONTRACTOR.
 - WELDING AND FABRICATION OF STEEL STRUCTURES SHALL BE IN ACCORDANCE WITH SECTIONS I THRU 6 OF THE ANSI/AASHTO/AWS D1.5 BRIDGE WELDING CODE AND SECTION 10 OF THE ANSI/AWS D.1 STRUCTURAL WELDING CODE. SURFACES TO BE WELDED SHALL BE FREE OF SCALE, SLAG, RUST, MOISTURE, GREASE OR ANY OTHER MATERIAL THAT WILL PREVENT PROPER WELDING OR PRODUCE OBJECTIONAL FUMES. WELDING SHALL BE SHIELDED METAL ARC WELDING USING PROPERLY DRIED 5/32" DIA. E7018 ELECTRODES.
 - AFTER REMOVAL OF THE BARRIER, THE HOLES IN THE SURFACE ON WHICH THE BARRIER SAT WHICH WERE USED TO ANCHOR THE SYSTEM, SHALL BE FILLED. THE ONLY EXCEPTION IS WHEN THE HOLES ARE IN AN AREA WHICH IS TO BE REMOVED. HOLES IN FLEXIBLE PAVEMENT, OR UNPAVED AREAS SHALL BE FILLED AS DIRECTED. HOLES IN PORTLAND CEMENT CONCRETE PAVEMENTS OR STRUCTURAL DECK, SHALL BE FILLED WITH NON-SHRINK GROUT MATERIAL MEETING THE REQUIREMENTS OF SECTION 914.03, EXCEPT THAT IN LATEX MODIFIED CONCRETE BRIDGE DECK, A COMPATIBLE NON-SHRINK GROUT MATERIAL SHALL BE USED.
- NOTE A**
THE LENGTH OF THE ANCHOR PINS SHALL BE SUCH THAT THE FOLLOWING MINIMUM EMBEDMENT LENGTHS ARE OBTAINED:
(a) INTO PORTLAND CEMENT CONCRETE PAVEMENT 0'-5"
(b) INTO FLEXIBLE PAVEMENT 1'-6"
(c) INTO UNPAVED AREA 2'-6"
- WHEN ANCHOR PINS ARE IN PLACE, THEY SHALL NOT PROJECT ABOVE THE PLANE OF THE CONCRETE SURFACE OF THE BARRIER.
HOLES IN BRIDGE DECK SHALL BE 1/4" DIAMETER MAXIMUM AND MADE WITH A CORE DRILL OR ANY OTHER APPROVED ROTARY DRILLING DEVICE THAT DOES NOT IMPART AN IMPACT FORCE.
- NOTE B**
IN UNITS THAT ARE TO BE ANCHORED, PINS SHALL BE REQUIRED IN EVERY ANCHOR RECESS.
- NOTE C**
FOR INSTALLATION ON BRIDGE DECKS REFER TO BRIDGE PLANS FOR NECESSARY MODIFICATIONS AS REQUIRED AND GENERAL NOTE 16.

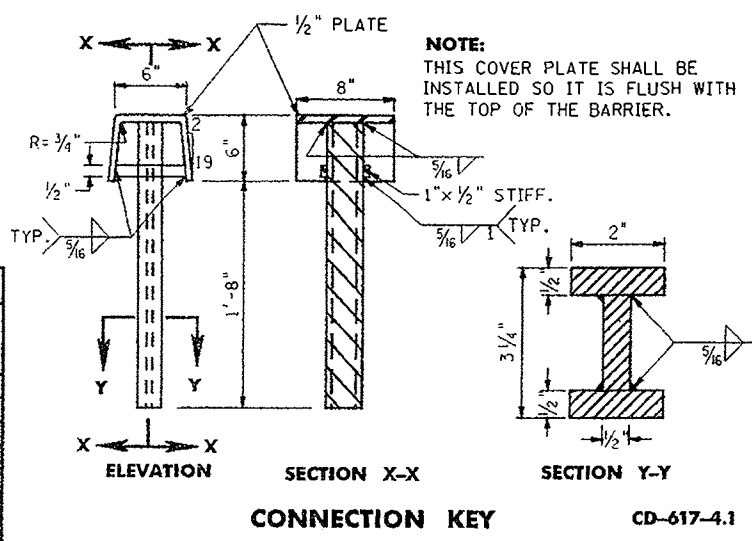

NOTES:
REINFORCING BARS ARE IN METRIC UNITS.

PRECAST CONCRETE CURB, CONSTRUCTION BARRIER, TYPE 4 (ALTERNATE A)
N.T.S.

NEW JERSEY DEPARTMENT OF TRANSPORTATION

CONSTRUCTION DETAILS

CD-617-4

65
129

PRECAST CONCRETE CURB, CONSTRUCTION BARRIER JOINT CONNECTION DETAILS

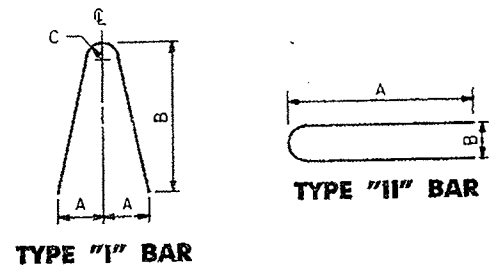
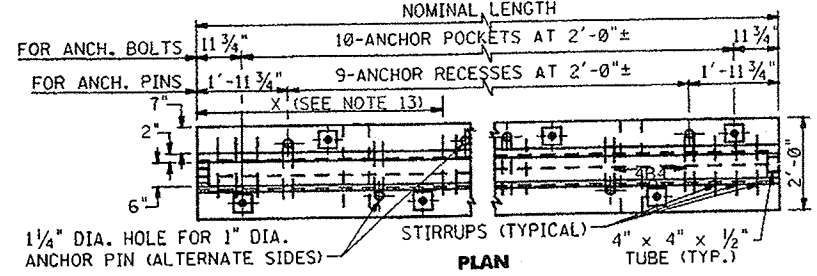
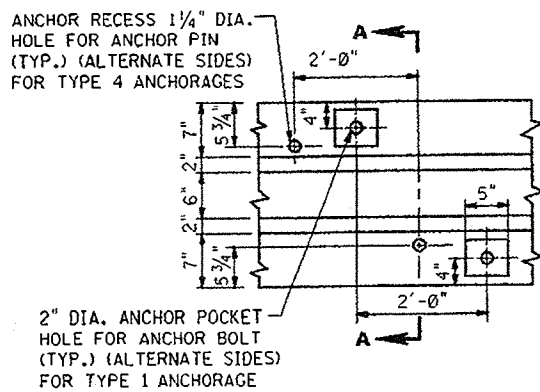
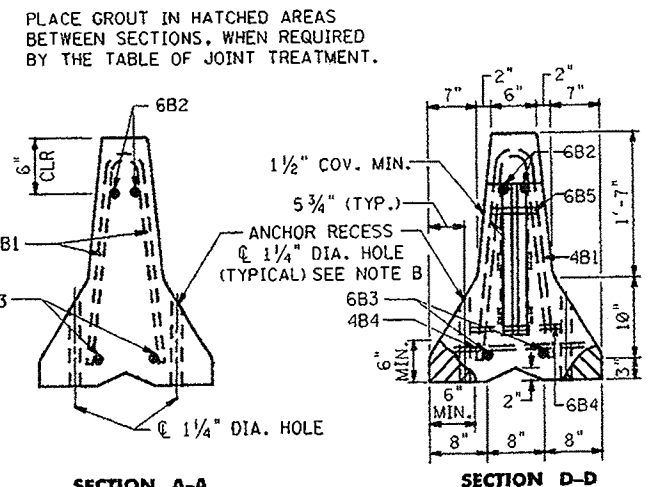
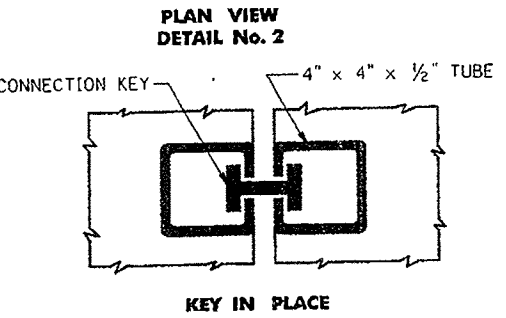
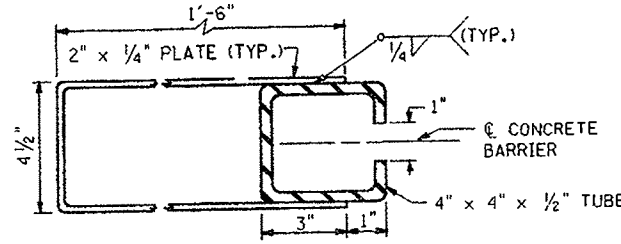
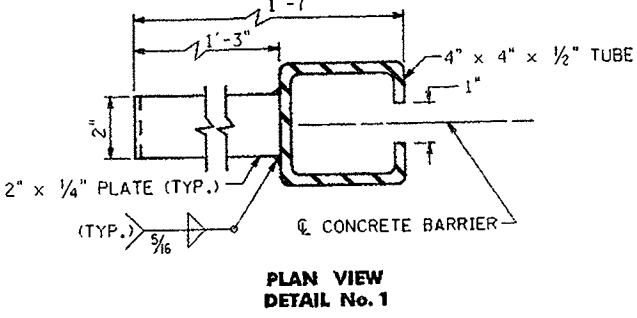
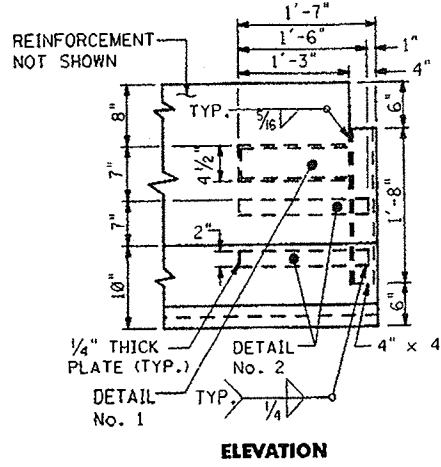
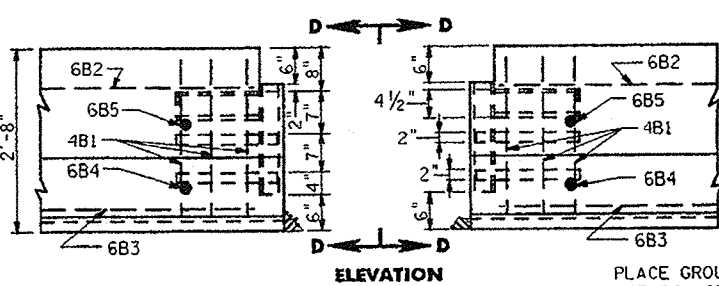
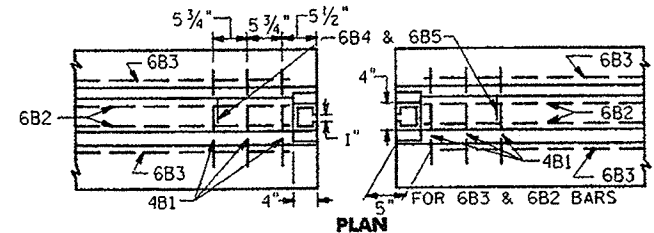

- GENERAL NOTES:**
1. STEEL PLATE SHALL BE ASTM A36, A588, A441 OR A572 GRADE 50.
 2. REINFORCING BARS SHALL BE AASHTO M31M, GRADE 420.
 3. CONCRETE SHALL BE WHITE CONCRETE CLASS B.
 4. CONCRETE CLEAR COVER FOR REINFORCING BARS SHALL BE 1 1/2" (MIN.)
 5. A MINIMUM OF (2) TWO RECESSED LIFTING DEVICES SHALL BE USED ON EACH SECTION. EACH LIFTING DEVICE SHALL HAVE A MINIMUM CAPACITY OF 6 TONS.
 6. TUBE STEEL SHALL BE ASTM A500, GRADE B OR C.
 7. ANCHOR PINS SHALL BE 1 INCH DIA. ASTM A36.
 8. ANCHOR PINS ARE NOT REQUIRED IN EVERY UNIT. SEE TABLE OF JOINT TREATMENTS.
 9. ALL END SECTIONS SHALL BE PINNED UNLESS OTHERWISE NOTED.
 10. 2 3/8" X 5 1/2" DRAINAGE POCKETS - TWO REQUIRED IN SECTIONS 12 FEET AND GREATER, ONE REQUIRED IN 8 FOOT AND 10 FOOT SECTIONS.
 11. AFTER A BARRIER UNIT HAS BEEN PLACED AND THE CONNECTION KEY INSERTED, REMOVE ANY SLACK IN THE JOINT BY PULLING THE UNIT IN A DIRECTION PARALLEL TO IT'S LONGITUDINAL AXIS.
 12. THE PRECAST CONCRETE CURB, CONSTRUCTION BARRIER SHALL BE CAST IN STEEL FORMS.
 13. THE PRECAST CONCRETE CURB SHALL BE UNITS OF 20 FEET, HOWEVER, OTHER LENGTHS MAY BE USED TO MEET FIELD CONDITIONS. THE NUMBER AND PLACEMENT OF THE 4B4 AND 4B5 BARS WILL VARY WITH THE LENGTH OF THE BARRIER UNIT AS SHOWN ON THE TABLE OF VARIABLE BARS. THE 6B2 AND 6B3 BARS SHALL BE 10 INCHES SHORTER THAN THE NOMINAL LENGTH OF THE BARRIER UNITS.
 14. REINFORCING SHOWN IS THE MINIMUM REQUIRED. ADDITIONAL REINFORCING NECESSARY FOR HANDLING SHALL BE THE OPTION AND RESPONSIBILITY OF THE CONTRACTOR.
 15. WELDING AND FABRICATION OF STEEL STRUCTURES SHALL BE IN ACCORDANCE WITH SECTIONS 1 THRU 6 OF THE ANSI/AASHTO/AWS D1.5 BRIDGE WELDING CODE AND SECTION 10 OF THE ANSI/AWS D.1 STRUCTURAL WELDING CODE. SURFACES TO BE WELDED SHALL BE FREE OF SCALE, SLAG, RUST, MOISTURE, GREASE OR ANY OTHER MATERIAL THAT WILL PREVENT PROPER WELDING OR PRODUCE OBJECTIONAL FUMES. WELDING SHALL BE SHIELDED METAL ARC WELDING USING PROPERLY DRIED 3/32" DIA. E7018 ELECTRODES.
 16. AFTER REMOVAL OF THE BARRIER, THE HOLES IN THE SURFACE ON WHICH THE BARRIER SAT WHICH WERE USED TO ANCHOR THE SYSTEM, SHALL BE FILLED. THE ONLY EXCEPTION IS WHEN THE HOLES ARE IN AN AREA WHICH IS TO BE REMOVED. HOLES IN FLEXIBLE PAVEMENT, OR UNPAVED AREAS SHALL BE FILLED AS DIRECTED. HOLES IN PORTLAND CEMENT CONCRETE PAVEMENTS OR STRUCTURAL DECKS, SHALL BE FILLED WITH NON-SHRINK GROUT MATERIAL MEETING THE REQUIREMENTS OF SECTION 914.03, EXCEPT THAT IN LATEX MODIFIED CONCRETE BRIDGE DECK, A COMPATIBLE NON-SHRINK GROUT MATERIAL SHALL BE USED.
 17. ONLY THE TYPE 4, JOINT CLASS D, SHALL BE USED AS BRIDGE PARAPETS.

- NOTE A**
THE LENGTH OF THE ANCHOR PINS SHALL BE SUCH THAT THE FOLLOWING MINIMUM EMBEDMENT LENGTHS ARE OBTAINED:
(a) INTO PORTLAND CEMENT CONCRETE PAVEMENT 0'-5"
(b) INTO FLEXIBLE PAVEMENT 1'-6"
(c) INTO UNPAVED AREA 2'-6"
- NOTE B**
WHEN ANCHOR PINS ARE IN PLACE, THEY SHALL NOT PROJECT ABOVE THE PLANE OF THE CONCRETE SURFACE OF THE BARRIER.
HOLES IN BRIDGE DECKS SHALL BE 1/4" DIAMETER MAXIMUM AND MADE WITH A CORE DRILL OR ANY OTHER APPROVED ROTARY DRILLING DEVICE THAT DOES NOT IMPART AN IMPACT FORCE.
- NOTE C**
FOR INSTALLATION ON BRIDGE DECKS REFER TO BRIDGE PLANS FOR NECESSARY MODIFICATIONS AS REQUIRED AND GENERAL NOTES 16 & 17.

JOINT CLASS	TABLE OF JOINT AND ANCHORAGE TREATMENTS FOR TYPE 4 APPLICATIONS ONLY
A	CONNECTION KEY ONLY
B	CONNECTION KEY AND GROUT IN EVERY JOINT
C	CONNECTION KEY AND GROUT IN EVERY JOINT AND PIN EVERY OTHER UNIT. IN UNITS THAT ARE TO BE ANCHORED, PINS SHALL BE REQUIRED IN EVERY ANCHOR PIN RECESS
D	CONNECTION KEY AND GROUT EVERY JOINT, BOLT EVERY ANCHOR POCKET HOLE IN EVERY UNIT.

TABLE OF VARIABLE BARS			
NOMINAL LENGTH OF BARRIER UNIT	MARK	"X" DISTANCE FROM END OF BARRIER TO 4B5 BAR	NO. EACH SECTION
20'	4B4	N.A.	9
20'	4B5	6'-11"	2
18'	4B4	N.A.	8
18'	4B5	6'-5"	2
16'	4B4	N.A.	7
16'	4B5	5'-11"	2
14'	4B4	N.A.	6
14'	4B5	7'-0"	1
12'	4B4	N.A.	5
12'	4B5	6'-0"	1
10'	4B4	N.A.	4
10'	4B5	5'-0"	1
8'	4B4	N.A.	3
8'	4B5	-	0

BARS LIST (EACH BARRIER SECTION)								
MARK	SIZE	NUMBER IN EACH SECTION	LENGTH	TYPE	A	B	C	LOCATION
4B1	#13	6	4'-11"	I	5"	26"	2"	STIRRUPS
4B4	#13	SEE NOTE 13	3'-1"	II	15 1/2"	4"		STIRRUPS
4B5	#13	SEE NOTE 13	4'-11"	I	5"	26"	2"	STIRRUPS
6B2	#19	2	SEE NOTE 13	STR.				LONGITUDINAL (TOP) NORMAL SECTION
6B3	#19	2	SEE NOTE 13	STR.				LONGITUDINAL (BOTTOM) NORMAL SECTION
6B4	#19	2	1'-2"	STR.				TRANSVERSE (BOTTOM) NORMAL SECTION
6B5	#19	2	0'-6"	STR.				TRANSVERSE (TOP) NORMAL SECTION

PRECAST CONCRETE CURB, CONSTRUCTION BARRIER, TYPE 4 (ALTERNATE B)
N.T.S.

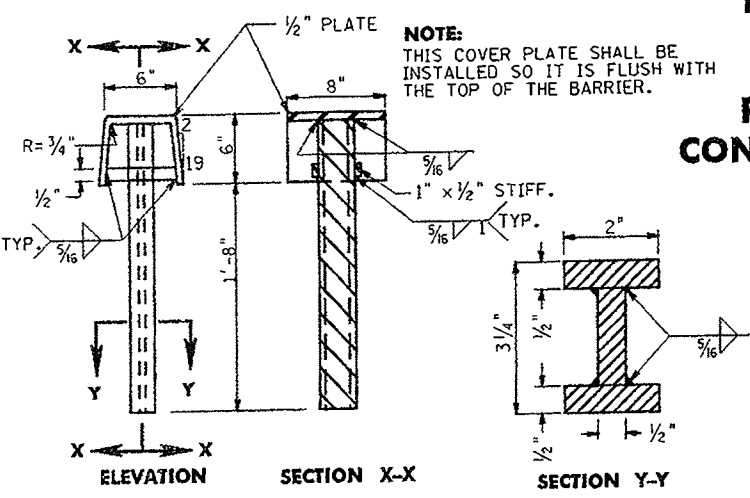

NEW JERSEY DEPARTMENT OF TRANSPORTATION

CONSTRUCTION DETAILS

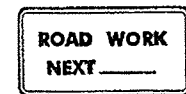

G20 - 1 [60" x 24"]
(10 S.F.)

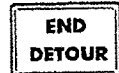

M4 - 8a [24" x 18"]
(3 S.F.)
M4 - 11 (S) [48" x 36"]
(12 S.F.)



R11 - 4 [60" x 30"]
(12.5 S.F.)



W20 - 7b [48" x 48"]
(16 S.F.)



(L OR R) (CENTER)
W20 - 5 [48" x 48"]
(16 S.F.)



W8 - 1 (S) [48" x 48"]
(16 S.F.)



G20 - 2A [48" x 24"]
(8 S.F.)



R2 - 1 [24" x 30"]
(5 S.F.)
R2 - 1 (S) [48" x 60"]
(20 S.F.)



(L OR R)
W1 - 4a [48" x 48"]
(16 S.F.)



W13 - 1 [18" x 18"]
(2.3 S.F.)
W13 - 1 (S) [24" x 24"]
(4 S.F.)



W20 - 7a [48" x 48"]
(16 S.F.)

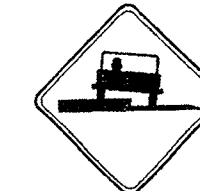

W8 - 9a [48" x 48"]
(16 S.F.)



M4 - 9L (LEFT) [30" x 24"]
M4 - 9R (RIGHT) [30" x 24"]
(5 S.F.)

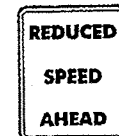

R2 - 5a [24" x 30"]
(5 S.F.)
R2 - 5a (S) [48" x 60"]
(20 S.F.)



(L OR R)
W1 - 6 [48" x 24"]
(8 S.F.)
W1 - 6 (S) [60" x 30"]
(12.5 S.F.)



W20 - 1A [48" x 48"]
(16 S.F.)



W21 - 5 (S) [48" x 48"]
(16 S.F.)



W8 - 14 [48" x 48"]
(16 S.F.)



M4 - 9LX (LEFT) [30" x 24"]
M4 - 9RX (RIGHT) [30" x 24"]
(5 S.F.)



R4 - 1 [24" x 30"]
(5 S.F.)

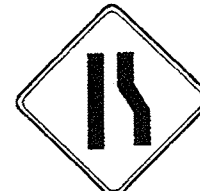

(L OR R)
W4 - 2 (S) [48" x 48"]
(16 S.F.)

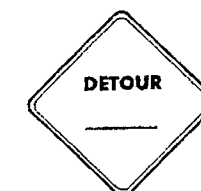

W20 - 2 [48" x 48"]
(16 S.F.)



M4 - 9N [30" x 12" MIN.]
(2.5 S.F.)
(SIZE WILL VARY WITH LENGTH OF STREET NAME)
STREET NAME SIGN TO BE USED IN CONJUNCTION WITH M4 - 9 SIGNS BLACK ON ORANGE



W8 - 14A [48" x 48"]
(16 S.F.)



M4 - 9X [30" x 24"]
(5 S.F.)



R11 - 2 [48" x 30"]
(10 S.F.)



W5 - 1 (S) [48" x 48"]
(16 S.F.)



W20 - 3 [48" x 48"]
(16 S.F.)



[24" x 24"]
(4 S.F.)
[30" x 30"] (S)
(6.3 S.F.)



W99 - 2 [48" x 48"]
(16 S.F.)



M4 - 10L (LEFT) [48" x 18"]
M4 - 10R (RIGHT) [48" x 18"]
(6 S.F.)

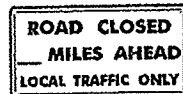

R11 - 3 [60" x 30"]
(12.5 S.F.)

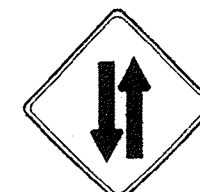

W6 - 3 [48" x 48"]
(16 S.F.)



W20 - 4 [48" x 48"]
(16 S.F.)



[24" x 24"]
(4 S.F.)
[30" x 30"] (S)
(6.3 S.F.)

GENERAL NOTES:

- DIMENSIONS, COLORS AND DETAILS OF VARIOUS SIZE SIGNS, AND ACCESSORY PANELS TO FOLLOW STANDARDS IN THE CURRENT "STANDARD HIGHWAY SIGN PUBLICATION" AND THE CURRENT "MANUAL ON UNIFORM TRAFFIC CONTROL DEVICES FOR STREETS AND HIGHWAYS".
- (S) REPRESENTS A SPECIAL SIZE SIGN.
- LETTERS AND NUMERALS SHALL CONFORM TO THE CURRENT MANUAL, "STANDARD ALPHABETS FOR HIGHWAY SIGNS" U.S. DEPARTMENT OF TRANSPORTATION, FEDERAL HIGHWAY ADMINISTRATION.
- THE CONTRACTOR SHALL OBTAIN THE APPROVAL OF THE ENGINEER FOR THE DISTANCE TO BE USED ON THE ADVANCE WARNING SIGNS, AND FOR THE SPEED LIMIT TO BE USED ON THE R2-1 SIGN.
- DISTANCE LEGEND: SIGN NUMBER FOLLOWED BY LETTER & DISTANCE

LETTER	DISTANCE
A	1500'
B	1000'
C	500'
D	— MILE
E	— MILES AHEAD
F	— AHEAD

BACKING MATERIAL

- ALUMINUM SHALL BE FLAT SHEET OF ALLOY 5052-H38 OR 6061-T6 ALLOY, 0.10 GAUGE.

TEMPORARY SIGN SUPPORTS

- SIGN SUPPORTS SHALL BE OF WELL SEASONED LUMBER, S4S, FREE OF SPLITS, KNOTS AND WARPS, OR OF STEEL COMPONENTS.
- WOOD POSTS SHALL HAVE A UNIFORM CROSS-SECTION AND SHALL NOT EXCEED THE FOLLOWING DIMENSIONS FOR:

SINGLE POST = 4" x 6"
TWO POSTS = 3" x 6" OR 4" x 5"
THREE POSTS = 3" x 5" OR 4" x 4"

4" X 6" WOOD POSTS SHALL BE MODIFIED BY DRILLING 1/2 INCH DIAMETER HOLES 4 INCHES AND 18 INCHES ABOVE THE GROUND LINE AND PERPENDICULAR TO THE ROADWAY CENTERLINE.

- NO BRACING IS PERMITTED. VERTICAL CLEARANCES FOR SIGNS MOUNTED ON WOOD SUPPORTS SHALL BE 7 FOOT MINIMUM. EMBEDMENT DEPTH FOR THE WOOD POST SHALL NOT EXCEED 3.5 FEET.
- STEEL POSTS SHALL BE IN ACCORDANCE WITH THE STANDARD DETAIL FOR U-POST SIGN SUPPORT.
- TEMPORARY SIGN SUPPORTS NOT MEETING THIS CRITERIA SHALL BE SHIELDED BY A LONGITUDINAL BARRIER OR CRASH CUSHIONS.

SIGN FACES

- SIGN FACES SHALL BE RETROREFLECTIVE SHEETING, TYPE II OR IIIA, EXCEPT FOR THE W20 SERIES AND W4-2 SIGN FACES WHICH SHALL BE TYPE IV-B SHEETING.

FASTENING

- ALL SIGNS SHALL BE SECURELY FASTENED TO THEIR SUPPORTS WITH BOLTS, NUTS AND WASHERS IN ACCORDANCE WITH THE SPECIFICATIONS.

CONSTRUCTION SIGNS N.T.S.

CD-617-6

NEW JERSEY DEPARTMENT OF TRANSPORTATION

CONSTRUCTION DETAILS

CD-617-6.1



E5 - 1 [60" x 48"]
(20 S.F.)



W50 - 1C [60" x 48"]
(20 S.F.)



W5 - 4 [48" x 48"]
(16 S.F.)



WINJ100 - 1(L OR R)
48" x 48"
(16 S.F.)



W9 - 3 a [48" x 48"]
(16 S.F.)



W20 - 4F(M) [48" x 48"]
(16 S.F.)



W20 - 10(G) [48" x 48"]
(16 S.F.)

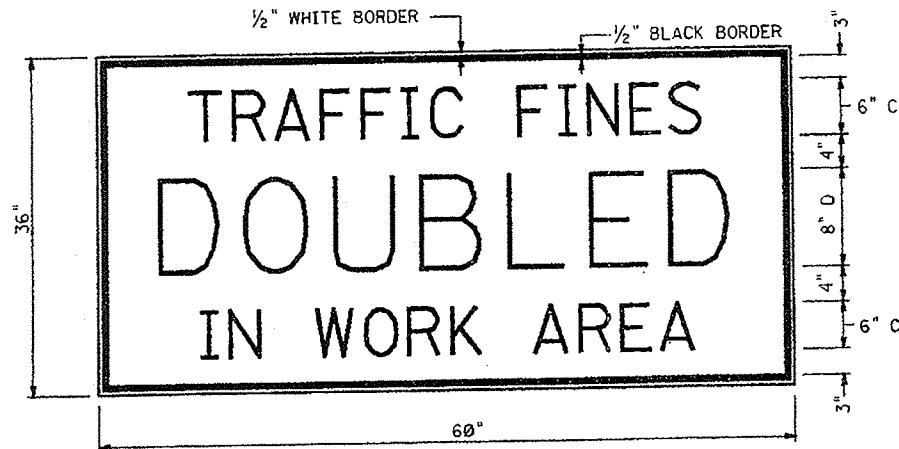

NOTE:
MESSAGE TO BE BLACK LETTERS
ON WHITE REFLECTIVE BACKGROUND.

R(NJ)5-17 60" x 36"
(15 S.F.)

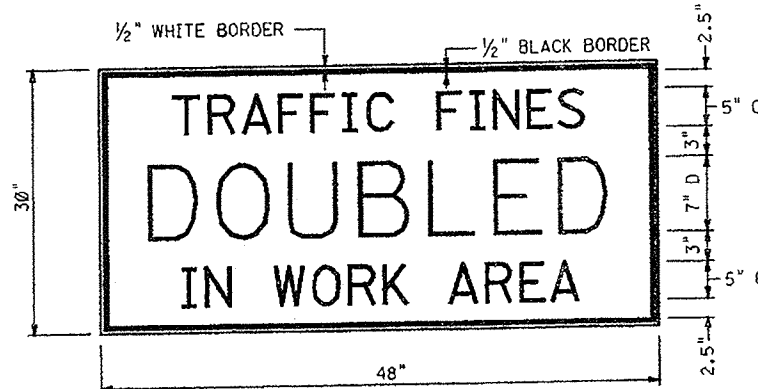

NOTE:
MESSAGE TO BE BLACK LETTERS
ON WHITE REFLECTIVE BACKGROUND.

R(NJ)5-17 48" x 30"
(10 S.F.)

GENERAL NOTES:

- DIMENSIONS, COLORS AND DETAILS OF VARIOUS SIZE SIGNS, AND ACCESSORY PANELS TO FOLLOW STANDARDS IN THE CURRENT "STANDARD HIGHWAY SIGN PUBLICATION" AND THE CURRENT "MANUAL ON UNIFORM TRAFFIC CONTROL DEVICES FOR STREETS AND HIGHWAYS".
- LETTERS AND NUMERALS SHALL CONFORM TO THE CURRENT MANUAL, "STANDARD ALPHABETS FOR HIGHWAY SIGNS" U.S. DEPARTMENT OF TRANSPORTATION, FEDERAL HIGHWAY ADMINISTRATION.
- THE CONTRACTOR SHALL OBTAIN THE APPROVAL OF THE ENGINEER FOR THE DISTANCE TO BE USED ON THE ADVANCE WARNING SIGNS, AND FOR THE SPEED LIMIT TO BE USED ON THE R2-1 SIGN.
- DISTANCE LEGEND: SIGN NUMBER FOLLOWED BY LETTER & DISTANCE

LETTER	DISTANCE
A	1500'
B	1000'
C	500'
D	MILE
E	MILES AHEAD
F	AHEAD

BACKING MATERIAL

- ALUMINUM SHALL BE FLAT SHEET OF ALLOY 5052-H38 OR 6061-T6 ALLOY, 0.10 GAUGE.

TEMPORARY SIGN SUPPORTS

- SIGN SUPPORTS SHALL BE OF WELL SEASONED LUMBER, S4S, FREE OF SPLITS, KNOTS AND WARPS, OR OF STEEL COMPONENTS.
- WOOD POSTS SHALL HAVE A UNIFORM CROSS-SECTION AND SHALL NOT EXCEED THE FOLLOWING DIMENSIONS FOR:

SINGLE POST = 4" x 6"
 TWO POSTS = 3" x 6" OR 4" x 5"
 THREE POSTS = 3" x 5" OR 4" x 4"

4" x 6" WOOD POSTS SHALL BE MODIFIED BY DRILLING 1 1/2 INCH DIAMETER HOLES 4 INCHES AND 18 INCHES ABOVE THE GROUND LINE AND PERPENDICULAR TO THE ROADWAY CENTERLINE.

- NO BRACING IS PERMITTED. VERTICAL CLEARANCES FOR SIGNS MOUNTED ON WOOD SUPPORTS SHALL BE 7 FOOT MINIMUM. EMBEDMENT DEPTH FOR THE WOOD POST SHALL NOT EXCEED 3.5 FEET.
- STEEL POSTS SHALL BE IN ACCORDANCE WITH THE STANDARD DETAIL FOR U-POST SIGN SUPPORT.
- TEMPORARY SIGN SUPPORTS NOT MEETING THIS CRITERIA SHALL BE SHIELDED BY A LONGITUDINAL BARRIER OR CRASH CUSHIONS.

SIGN FACES

- SIGN FACES SHALL BE RETROREFLECTIVE SHEETING, TYPE II OR IIIA, EXCEPT FOR THE W20 SERIES AND W4-2 SIGN FACES WHICH SHALL BE TYPE IV-B SHEETING.

FASTENING

- ALL SIGNS SHALL BE SECURELY FASTENED TO THEIR SUPPORTS WITH BOLTS, NUTS AND WASHERS IN ACCORDANCE WITH THE SPECIFICATIONS.

CONSTRUCTION SIGNS
N.T.S.

CD-617-7

NEW JERSEY DEPARTMENT OF TRANSPORTATION

CONSTRUCTION DETAILS

CD-617-7.1

SIGN NO. 1 (INTERSTATE)

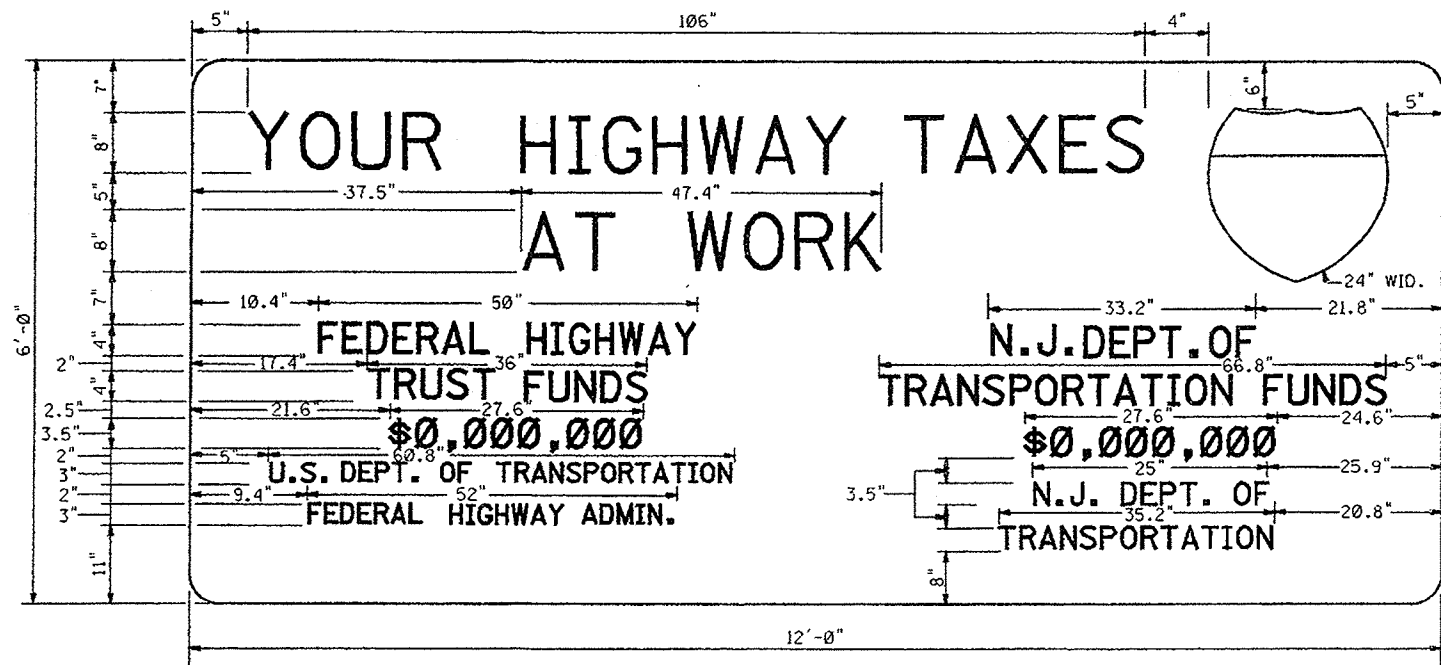

DETAILS OF SIGN NO. 1

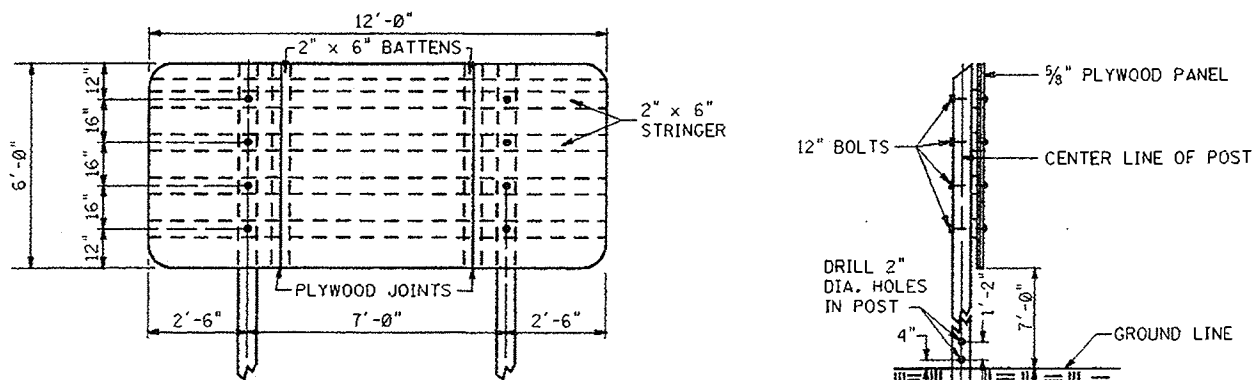

6" x 6" WOOD POST
DOUGLAS FIR COAST
REGION SELECT
STRUCTURAL OR
EQUAL

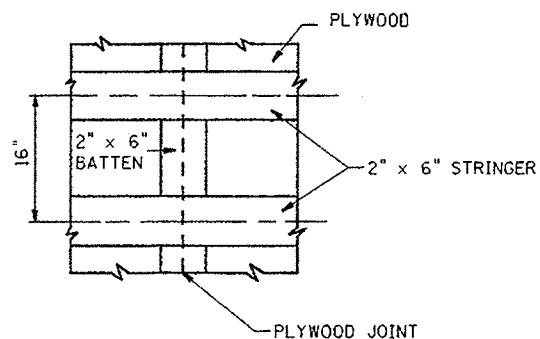

**DETAIL OF BATTEN
AT PLYWOOD JOINTS**

SIGN NO. 1

NOTES:

PLYWOOD PANELS SHALL COMFORM TO REQUIREMENTS FOR HIGH DENSITY OVERLAY AS SET FORTH IN COMMERCIAL STANDARD CS 45-60 FOR DOUGLAS FIR PLYWOOD AND ALL AMENDMENTS THERETO.

COSTS LISTED ON SIGNS TO BE FURNISHED BY ENGINEER AFTER AWARD OF CONTRACT.

SIGNS TO BE LOCATED AS SHOWN ON PLANS OR AS DIRECTED BY ENGINEER.

SHIELD TO COMFORM TO DETAILS SHOWN IN THE CURRENT "MANUAL ON UNIFORM TRAFFIC CONTROL DEVICES".

COLOR: GREEN BACKGROUND WITH WHITE MESSAGE AND BORDER NOT REFLECTORIZED.

LEGEND: SERIES "C" LETTERS - "YOUR HIGHWAY TAXES AT WORK"
SERIES "D" LETTERS (BALANCE OF LETTERING).

CORNER RADIUS: 3"

INTERSTATE SHIELD: RED, WHITE, AND BLUE

NOTE:

ON PROJECTS WITH NO FEDERAL FUNDING THE REFERENCE

FEDERAL HIGHWAY TRUST FUNDS
\$0,000,000
U.S. DEPT. OF TRANSPORTATION
FEDERAL HIGHWAY ADMIN.

SHALL NOT BE INCLUDED ON THE SIGN.

**INTERSTATE CONSTRUCTION
IDENTIFICATION SIGN**

N.T.S.

CD-617-8

NEW JERSEY DEPARTMENT OF TRANSPORTATION

CONSTRUCTION DETAILS

CD-617-8.1

SIGN NO. 3 (SECONDARY)

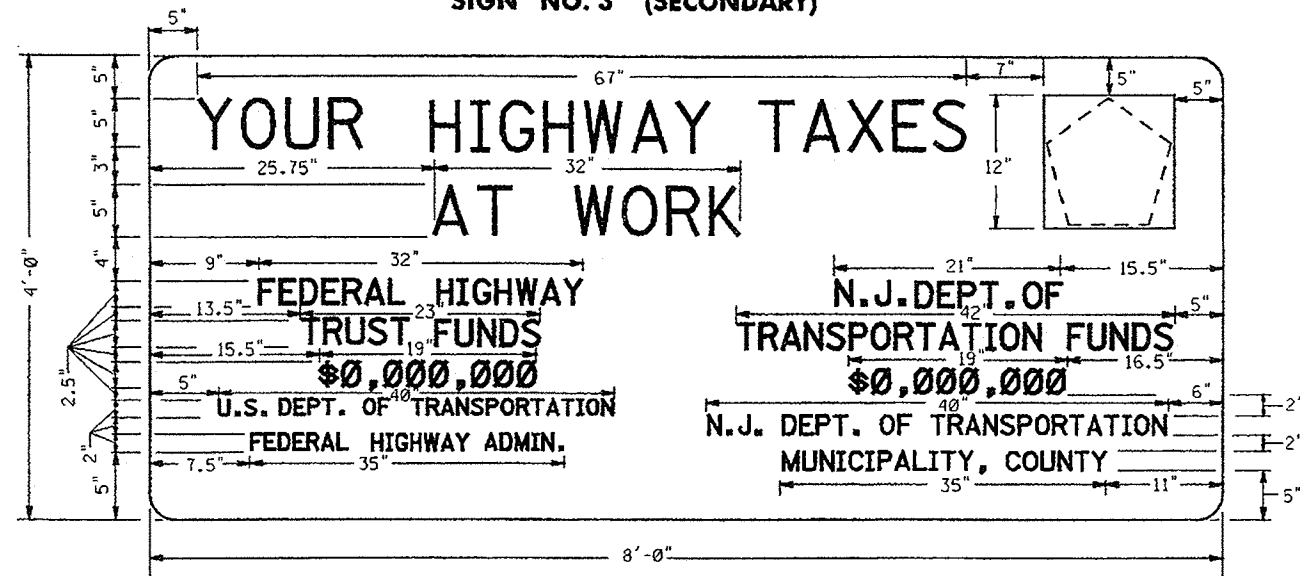

NOTE:
PENTAGON INSIGNIA TO BE USED WHEN POSTING COUNTY ROUTES.

SIGN NO. 2 (PRIMARY)

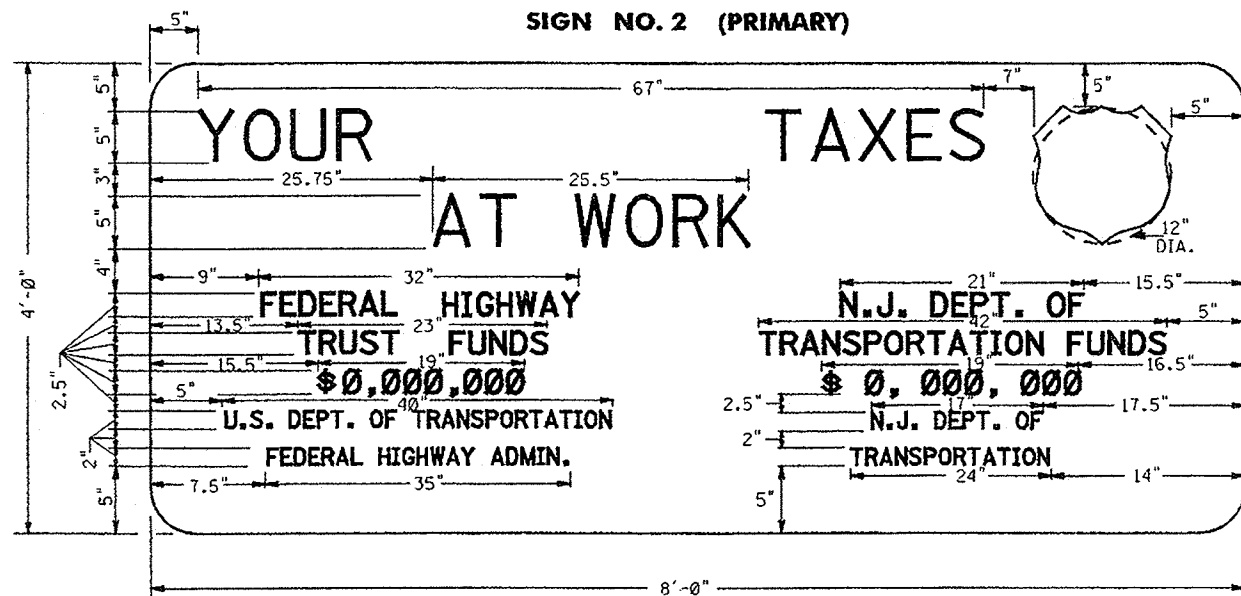

NOTE:
SHIELD INSIGNIA TO BE USED WHEN POSTING U. S. ROUTES.
CIRCLE INSIGNIA TO BE USED WHEN POSTING STATE ROUTES.

DETAILS OF SIGNS NO. 2 & 3

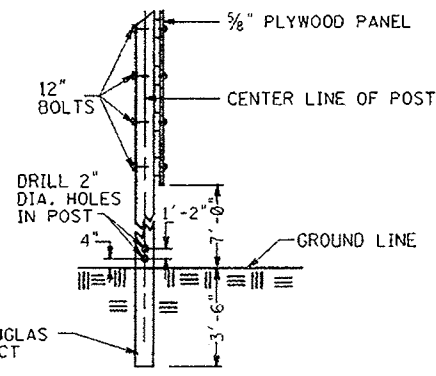
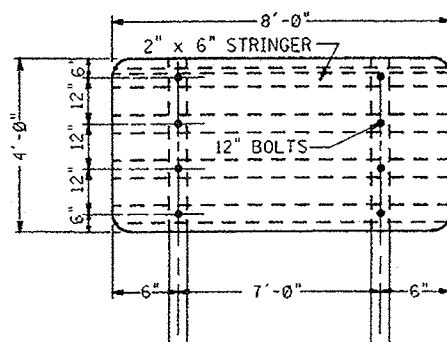

6" x 6" WOOD POST DOUGLAS FIR COAST REGION SELECT STRUCT. OR EQUAL

NOTE:
USE MODIFIED DETAIL BELOW WHEN NJDOT TRUST FUNDS ARE APPLICABLE FOR SIGNS #2 AND #3 (LOWER RIGHT HAND CORNER OF SIGNS).

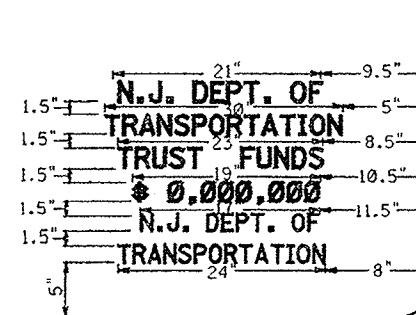

NOTES:

PLYWOOD PANELS SHALL CONFORM TO REQUIREMENTS FOR HIGH DENSITY OVERLAY AS SET FORTH IN COMMERCIAL STANDARD CS 45-60 FOR DOUGLAS FIR PLYWOOD AND ALL AMENDMENTS THERETO.

COSTS LISTED ON SIGNS TO BE FURNISHED BY ENGINEER AFTER AWARD OF CONTRACT.

SIGNS TO BE LOCATED AS SHOWN ON PLANS OR AS DIRECTED BY ENGINEER.

SHIELD TO CONFORM TO DETAILS SHOWN IN THE CURRENT "MANUAL ON UNIFORM TRAFFIC CONTROL DEVICES".

COLOR: GREEN BACKGROUND WITH WHITE MESSAGE AND BORDER NOT REFLECTORIZED.

LEGEND: SERIES "C" LETTERS - "YOUR HIGHWAY TAXES AT WORK"
SERIES "D" LETTERS (BALANCE OF LETTERING).

CORNER RADIUS: 3"

INTERSTATE SHIELD: RED, WHITE, AND BLUE

U.S. AND STATE SHIELDS: BLACK ON WHITE

COUNTY SHIELDS: GOLD ON BLUE

NOTE:

ON PROJECTS WITH NO FEDERAL FUNDING THE REFERENCE

FEDERAL HIGHWAY TRUST FUNDS
\$0,000,000
U.S. DEPT. OF TRANSPORTATION
FEDERAL HIGHWAY ADMIN.

SHALL NOT BE INCLUDED ON THE SIGN.

CONSTRUCTION IDENTIFICATION SIGNS

N.T.S.

NEW JERSEY DEPARTMENT OF TRANSPORTATION

CONSTRUCTION DETAILS

CD-617-9

CD-617-9.1

70
129

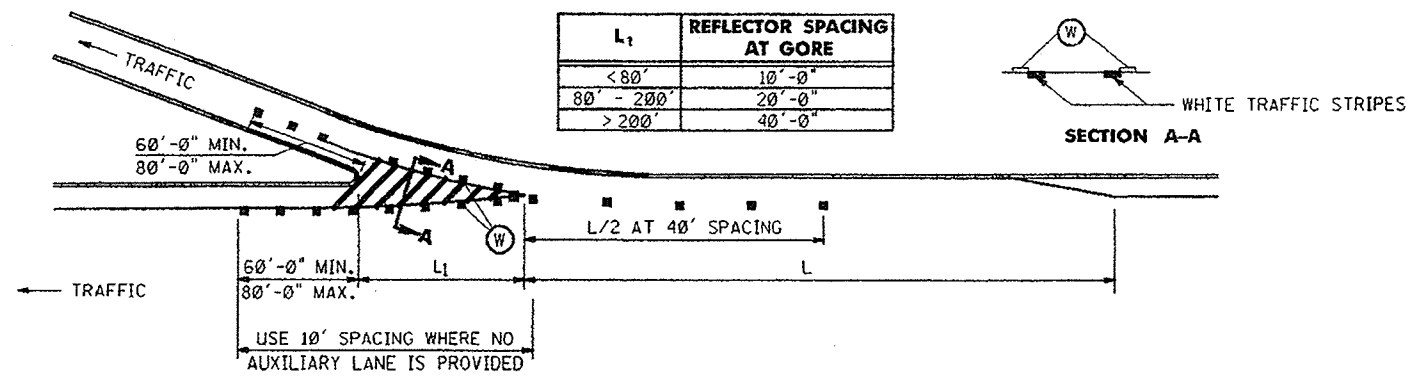

TYPICAL DECELERATION LANE TREATMENT

CD-618-1.1

LEGEND

- (W) TWO-WAY PLOWABLE MONO-DIRECTIONAL WHITE PAVEMENT REFLECTOR
- (A) TWO-WAY PLOWABLE MONO-DIRECTIONAL AMBER PAVEMENT REFLECTOR

CD-618-1.2

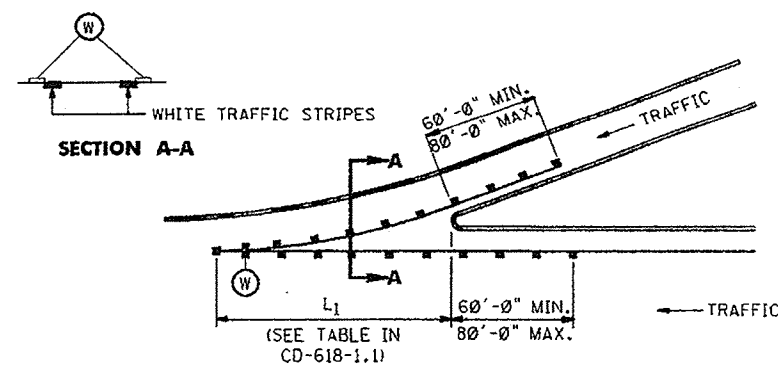

TYPICAL ACCELERATION LANE TREATMENT

CD-618-1.3

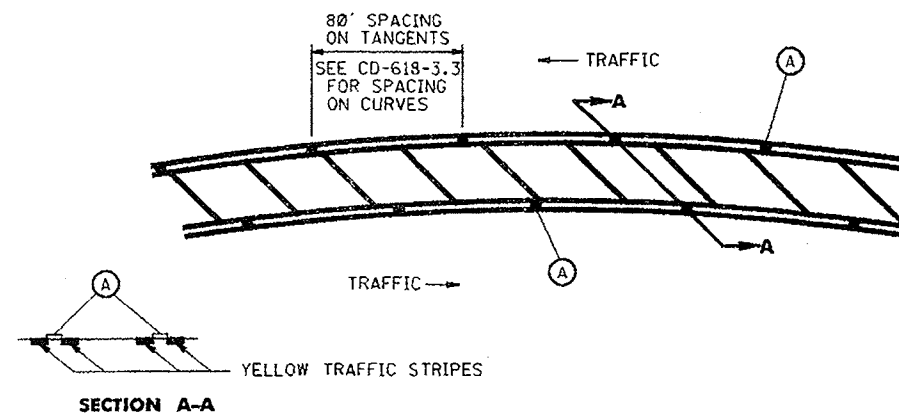

TYPICAL PAVED MEDIAN TREATMENT

CD-618-1.4

PLOWABLE PAVEMENT REFLECTOR LOCATION DETAILS
N.T.S.

CD-618-1

NEW JERSEY DEPARTMENT OF TRANSPORTATION

CONSTRUCTION DETAILS

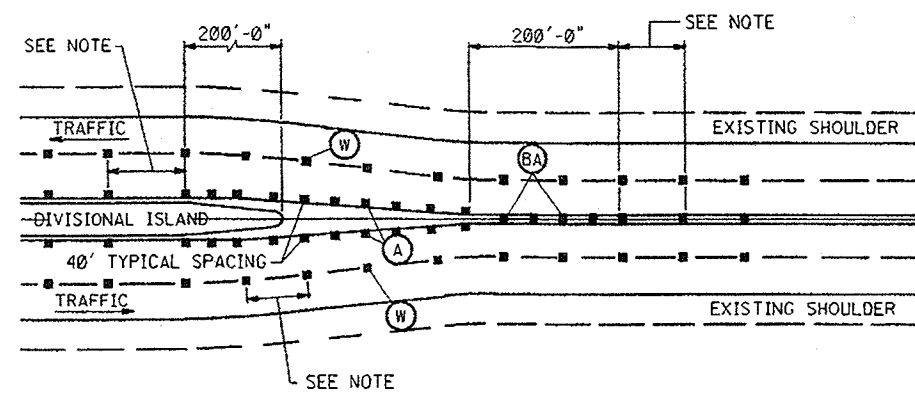

NOTE:
80 FOOT SPACING ON TANGENT FOR
SPACING ON CURVES SEE CD-618-3.3

TYPICAL DIVISIONAL ISLAND TREATMENT

CD-618-2.1

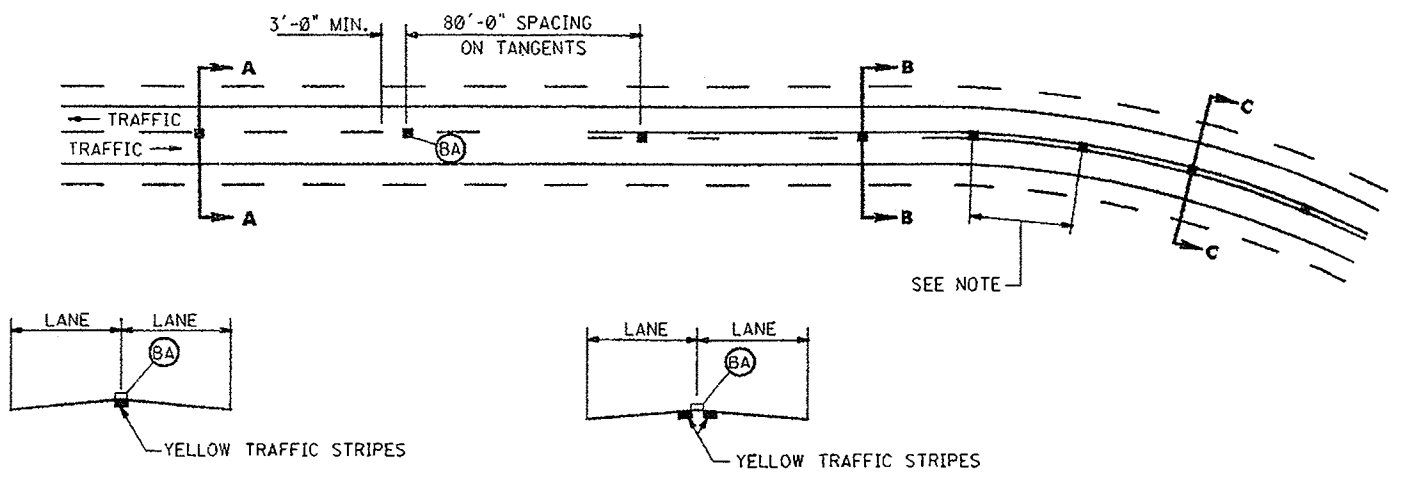

NOTE:
FOR SPACING ON CURVES SEE CD-618-3.3

TYPICAL TWO LANE SECTION

CD-618-2.4

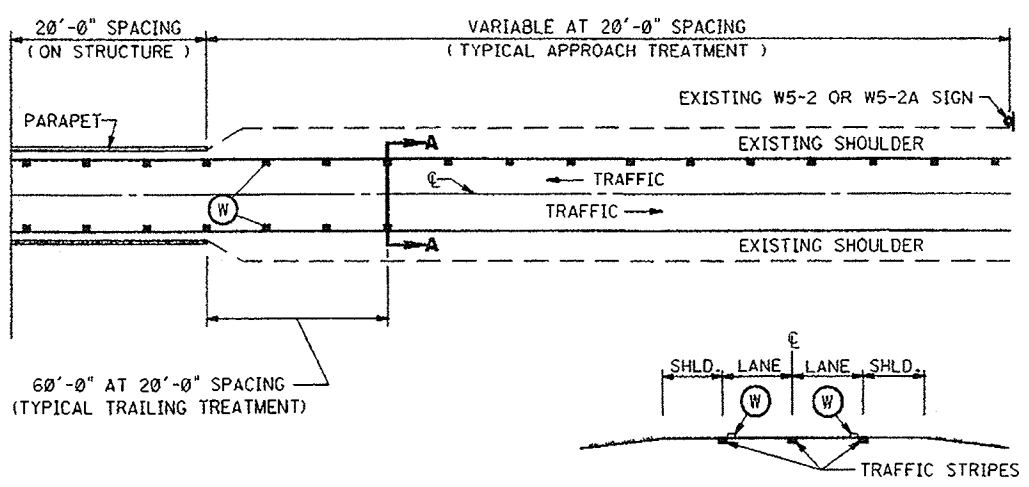

NARROW BRIDGE OR CULVERT TREATMENT

CD-618-2.2

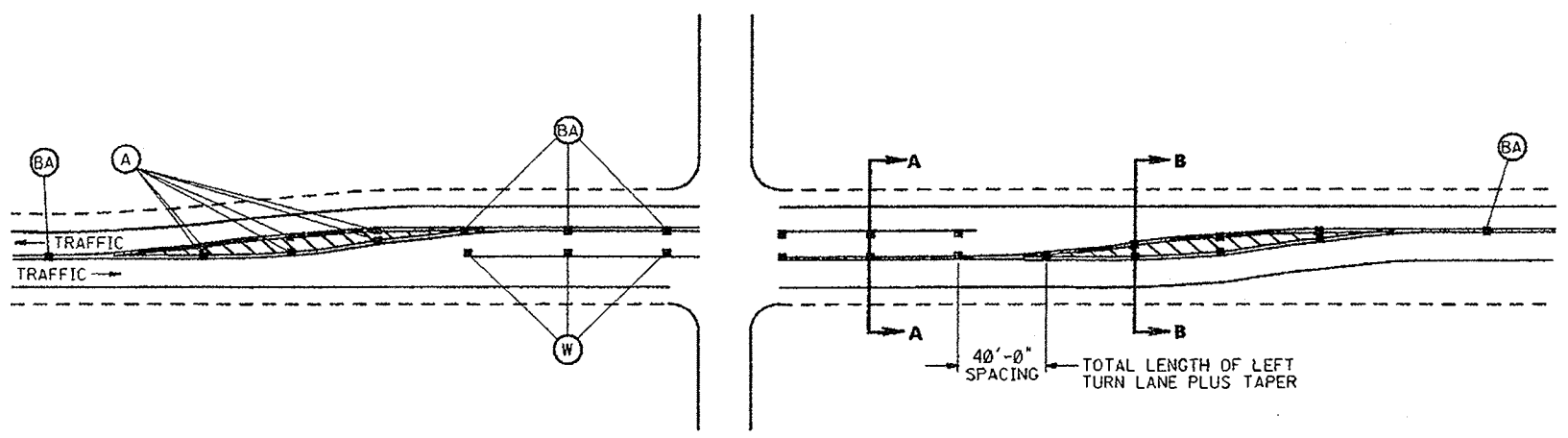

TYPICAL LEFT TURN LANE SECTION

CD-618-2.5

LEGEND

- (W) TWO-WAY PLOWABLE MONO-DIRECTIONAL WHITE PAVEMENT REFLECTOR
- (A) TWO-WAY PLOWABLE MONO-DIRECTIONAL AMBER PAVEMENT REFLECTOR
- (BA) TWO-WAY PLOWABLE BI-DIRECTIONAL AMBER PAVEMENT REFLECTOR

CD-618-2.3

PLOWABLE PAVEMENT REFLECTOR LOCATION DETAILS

N.T.S.

CD-618-2

NEW JERSEY DEPARTMENT OF TRANSPORTATION

CONSTRUCTION DETAILS

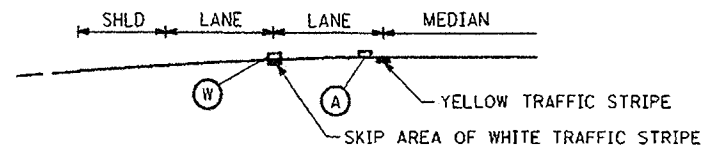

SECTION A-A (TYP.)

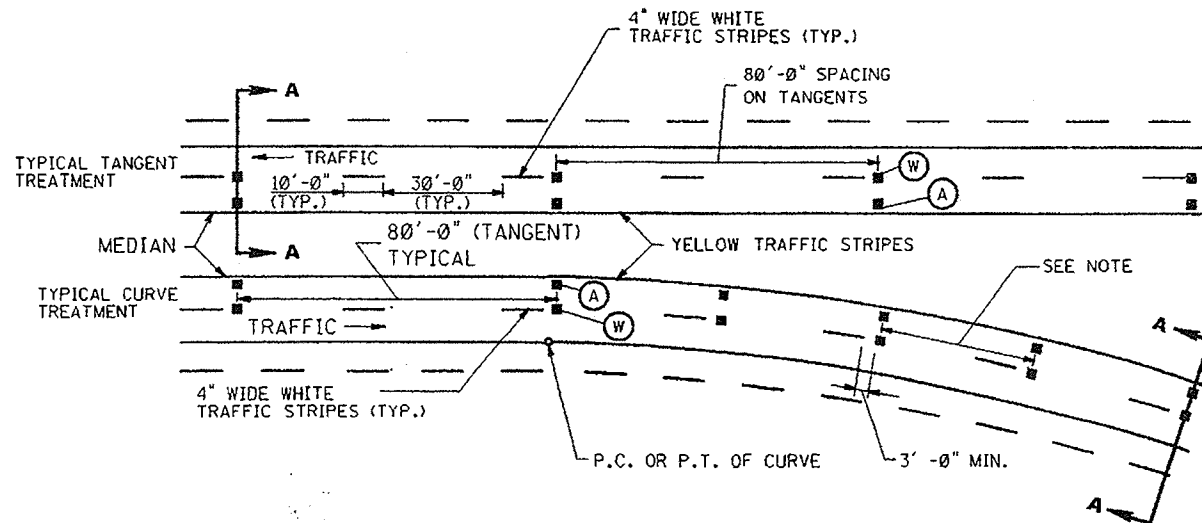

TYPICAL MULTI-LANE DIVIDED SECTION

NOTE:
FOR SPACING ON CURVES SEE CD-618-3.3

CD-618-3.1

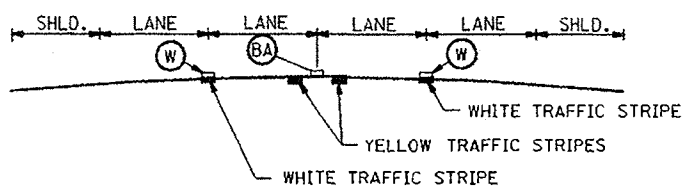

SECTION B-B

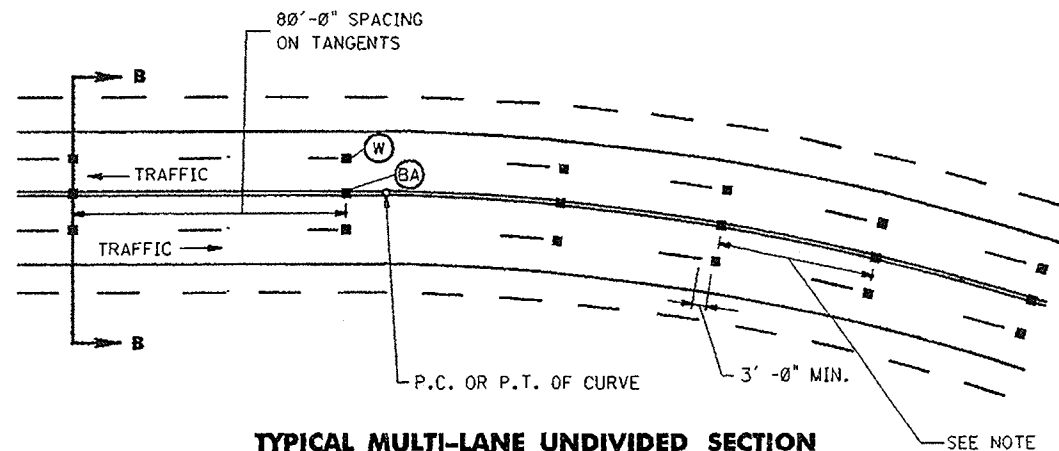

TYPICAL MULTI-LANE UNDIVIDED SECTION

NOTE:
FOR SPACING ON CURVES SEE CD-618-3.3

CD-618-3.2

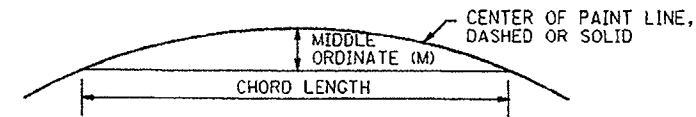

1. USE 200 FOOT TAPE.
2. ESTABLISH 200 FOOT CHORD.
3. MEASURE MIDDLE ORDINATE PERPENDICULAR TO CHORD 100 FOOT FROM EITHER END.
4. DETERMINE SPACING FROM TABLE 1.
5. WHEN DIFFICULT TO DETERMINE MIDDLE ORDINATE, 80 FOOT OR 40 FOOT SPACING WILL BE AS DIRECTED BY THE ENGINEER.

TABLE 1

CHORD LENGTH	MIDDLE ORDINATE	RADIUS	REFLECTOR SPACING
200'-0"	$M \geq 2'-7"$	$R \leq 1910'$	40'-0"
200'-0"	$M < 2'-7"$	$R > 1910'$	80'-0"

< LESS THAN
 \leq EQUAL TO OR LESS THAN
 > GREATER THAN
 \geq EQUAL TO OR GREATER THAN

METHOD FOR DETERMINING REFLECTOR SPACING ON HORIZONTAL CURVES

CD-618-3.3

LEGEND

- (W) TWO-WAY PLOWABLE MONO-DIRECTIONAL WHITE PAVEMENT REFLECTOR
- (A) TWO-WAY PLOWABLE MONO-DIRECTIONAL AMBER PAVEMENT REFLECTOR
- (BA) TWO-WAY PLOWABLE BI-DIRECTIONAL AMBER PAVEMENT REFLECTOR

CD-618-3.4

PLOWABLE PAVEMENT REFLECTOR LOCATION DETAILS

N.T.S.

CD-618-3

NEW JERSEY DEPARTMENT OF TRANSPORTATION

CONSTRUCTION DETAILS



M1 - 1 [1, 2 DIGITS - 24" x 24"]
(4 S.F.)
[3 DIGITS - 30" x 24"]
(5 S.F.)

M1 - 1 (S) [1, 2 DIGITS - 36" x 36"]
(9 S.F.)
[3 DIGITS - 45" x 36"]
(11.3 S.F.)



M1 - 4 [1, 2 DIGITS - 24" x 24"]
(4 S.F.)
[3 DIGITS - 30" x 24"]
(5 S.F.)

M1 - 4 (S) [1, 2 DIGITS - 36" x 36"]
(9 S.F.)
[3 DIGITS - 45" x 36"]
(11.3 S.F.)



M1 - 5 [1, 2 DIGITS - 24" x 24"]
(4 S.F.)
[3 DIGITS - 30" x 24"]
(5 S.F.)

M1 - 5 (S) [1, 2 DIGITS - 36" x 36"]
(9 S.F.)
[3 DIGITS - 45" x 36"]
(11.3 S.F.)



M1 - 6 [1, 2, 3 DIGITS - 24" x 24"]
(4 S.F.)

M1 - 6 (S) [1, 2, 3 DIGITS - 36" x 36"]
(9 S.F.)



NJTP - 1 [24" x 24"]
(4 S.F.)

NJTP - 1 (S) [36" x 36"]
(9 S.F.)



M2 - 1 [21" x 15"]
(2.2 S.F.)
M2 - 1 (S) [32" x 23"]
(5.1 S.F.)



M3 - 1 [24" x 12"]
(2 S.F.)
M3 - 1 (S) [36" x 18"]
(4.5 S.F.)

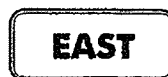

M3 - 2 [24" x 12"]
(2 S.F.)
M3 - 2 (S) [36" x 18"]
(4.5 S.F.)



M3 - 3 [24" x 12"]
(2 S.F.)
M3 - 3 (S) [36" x 18"]
(4.5 S.F.)



M3 - 4 [24" x 12"]
(2 S.F.)
M3 - 4 (S) [36" x 18"]
(4.5 S.F.)

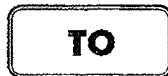

M4 - 5 [24" x 12"]
(2 S.F.)
M4 - 5 (S) [30" x 15"]
(3 S.F.)



(L or R)
M5 - 1 [21" x 15"]
(2.2 S.F.)
M5 - 1 (S) [32" x 23"]
(5.1 S.F.)



(L or R)
M5 - 2 [21" x 15"]
(2.2 S.F.)
M5 - 2 (S) [32" x 23"]
(5.1 S.F.)

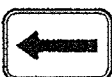

(L or R)
M6 - 1 [21" x 15"]
(2.2 S.F.)
M6 - 1 (S) [32" x 23"]
(5.1 S.F.)



(L or R)
M6 - 2 [21" x 15"]
(2.2 S.F.)
M6 - 2 (S) [32" x 23"]
(5.1 S.F.)



M6 - 3 [21" x 15"]
(2.2 S.F.)
M6 - 3 (S) [32" x 23"]
(5.1 S.F.)



M6 - 4 [21" x 15"]
(2.2 S.F.)
M6 - 4 (S) [32" x 23"]
(5.1 S.F.)

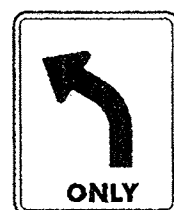

R3 - 5 [30" x 36"] (7.5 S.F.) OVERHEAD
R3 - 5 [30" x 30"] (6.3 S.F.) GROUND MOUNT

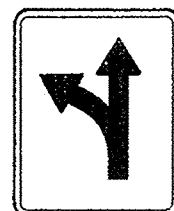

R3 - 6 [30" x 36"] (7.5 S.F.) OVERHEAD
R3 - 6 [30" x 30"] (6.3 S.F.) GROUND MOUNT

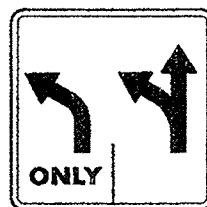

R3 - 8 [30" x 30"]
(6.3 S.F.)

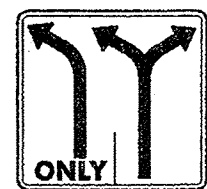

R(N)J3 - 8A [36" x 30"]
(7.5 S.F.)

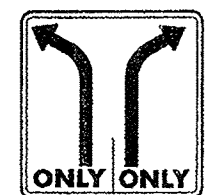

R(N)J3 - 8B [30" x 30"]
(6.3 S.F.)



R(N)J3 - 8C [48" x 30"]
(10 S.F.)

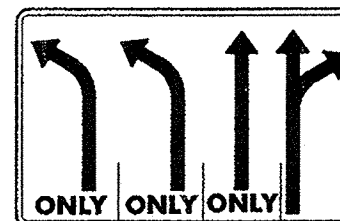

R(N)J3 - 8D [60" x 30"]
(12.5 S.F.)

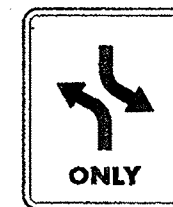

R3 - 9a [30" x 36"]
(7.5 S.F.)



R3 - 9b [24" x 36"]
(6 S.F.)

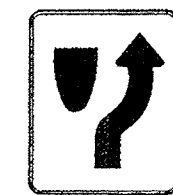

R4 - 7 [24" x 30"]
(5 S.F.)

R4 - 7 (S) [36" x 48"]
(12 S.F.)

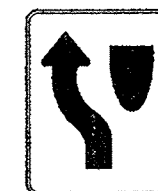

R4 - 8 [24" x 30"]
(5 S.F.)
R4 - 8 (S) [36" x 48"]
(12 S.F.)



GSP - 1 24" DIA.
(3.1 S.F.)
GSP - 1 (S) 36" DIA.
(7.1 S.F.)

GENERAL NOTES:

DIMENSIONS, COLORS, AND DETAILS OF VARIOUS SIZE SIGNS, SHIELDS AND ACCESSORY PANELS TO FOLLOW STANDARDS IN THE CURRENT "STANDARD HIGHWAY SIGNS PUBLICATION" AND THE CURRENT "MANUAL ON UNIFORM TRAFFIC CONTROL DEVICES FOR STREETS AND HIGHWAYS".

(S) DENOTES A SPECIAL SIZE SIGN.

ALL SIGNS SHALL BE OF THE ENCAPSULATED LENS TYPE.

SIGNS
N.T.S.

CD-619-1

NEW JERSEY DEPARTMENT OF TRANSPORTATION

CONSTRUCTION DETAILS

CD-619-1.1



R1 - 1 [30" x 30"]
(5.5 S.F.)



R1 - 2
[36" x 36" x 36"]
(3.9 S.F.)

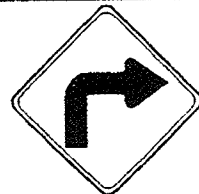

(L OR R)
W1 - 1 [30" x 30"]
(6.3 S.F.)
W1 - 1 (S) [36" x 36"]
(9 S.F.)

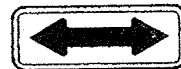

W1 - 7 [48" x 24"]
(8 S.F.)
W1 - 7 (S) [60" x 30"]
(12.5 S.F.)

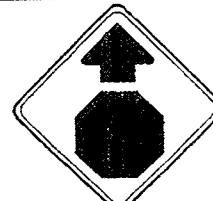

W3 - 1a [30" x 30"]
(6.3 S.F.)
W3 - 1a (S) [48" x 48"]
(16 S.F.)

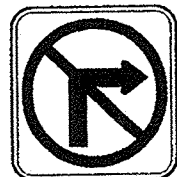

R3 - 1 [24" x 24"]
(4 S.F.)
R3 - 1 (S) [30" x 30"]
(6.3 S.F.)

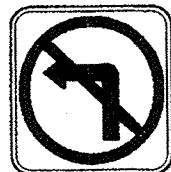

R3 - 2 [24" x 24"]
(4 S.F.)
R3 - 2 (S) [30" x 30"]
(6.3 S.F.)



(L OR R)
W1 - 2 [30" x 30"]
(6.3 S.F.)
W1 - 2 (S) [36" x 36"]
(9 S.F.)



(L OR R)
W1 - 8 [18" x 24"]
(3 S.F.)
W1 - 8 (S) [24" x 30"]
(5 S.F.)

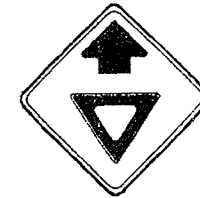

W3 - 2a [30" x 30"]
(6.3 S.F.)
W3 - 2a (S) [48" x 48"]
(16 S.F.)



R3 - 3 [24" x 24"]
(4 S.F.)
R3 - 3 (S) [30" x 30"]
(6.3 S.F.)



R3 - 4 [24" x 24"]
(4 S.F.)
R3 - 4 (S) [30" x 30"]
(6.3 S.F.)



(L OR R)
W1 - 3 [30" x 30"]
(6.3 S.F.)
W1 - 3 (S) [36" x 36"]
(9 S.F.)

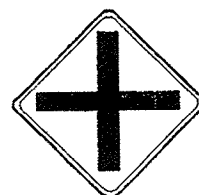

W2 - 1 [30" x 30"]
(6.3 S.F.)
W2 - 1 (S) [36" x 36"]
(9 S.F.)

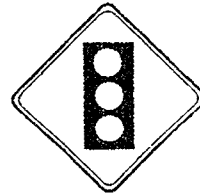

W3 - 3 [36" x 36"]
(9 S.F.)
W3 - 3 (S) [48" x 48"]
(16 S.F.)



(L OR R)
R3 - 7 [30" x 30"]
(6.3 S.F.)



R5 - 1 [30" x 30"]
(6.3 S.F.)
R5 - 1 (S) [36" x 36"]
(9 S.F.)



(L OR R)
W1 - 4 [30" x 30"]
(6.3 S.F.)
W1 - 4 (S) [36" x 36"]
(9 S.F.)

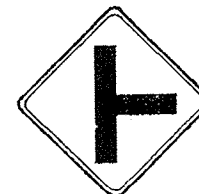

(L OR R)
W2 - 2 [30" x 30"]
(6.3 S.F.)
W2 - 2 (S) [36" x 36"]
(9 S.F.)



W4 - 1 [36" x 36"]
(9 S.F.)
W4 - 1 (S) [48" x 48"]
(16 S.F.)
W4 - 1 (EXPWY) [36" x 36"]
(9 S.F.)



R5 - 1a [36" x 24"]
(6 S.F.)
R5 - 1a (S) [30" x 18"]
(3.8 S.F.)



(L OR R)
R6 - 1 [36" x 12"]
(3 S.F.)



(L OR R)
W1 - 5 [30" x 30"]
(6.3 S.F.)
W1 - 5 (S) [36" x 36"]
(9 S.F.)

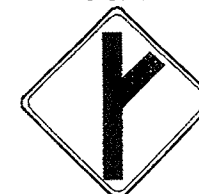

(L OR R)
W2 - 3 [30" x 30"]
(6.3 S.F.)
W2 - 3 (S) [36" x 36"]
(9 S.F.)

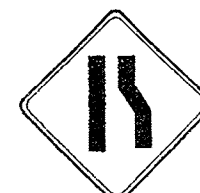

(L OR R)
W4 - 2 [36" x 36"]
(9 S.F.)
W4 - 2 (S) [48" x 48"]
(16 S.F.)

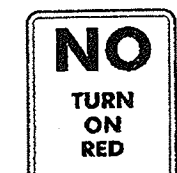

R10 - 11a [24" x 30"]
(5 S.F.)

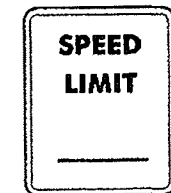

R2 - 1 [24" x 30"]
(5 S.F.)
R2 - 1 (EXPWY) [36" x 48"]
(12 S.F.)
R2 - 1 (S) [48" x 60"]
(20 S.F.)

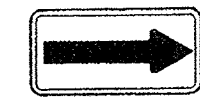

(L OR R)
W1 - 6 [48" x 24"]
(8 S.F.)
W1 - 6 (S) [60" x 30"]
(12.5 S.F.)



W2 - 5 [30" x 30"]
(6.3 S.F.)
W2 - 5 (S) [36" x 36"]
(9 S.F.)

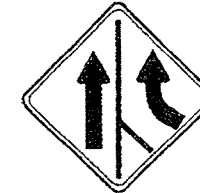

(L OR R)
W4 - 3 [36" x 36"]
(9 S.F.)
W4 - 3 (S) [48" x 48"]
(16 S.F.)

GENERAL NOTES:

DIMENSIONS, COLORS, AND DETAILS OF VARIOUS SIZE SIGNS, SHIELDS AND ACCESSORY PANELS TO FOLLOW STANDARDS IN THE CURRENT "STANDARD HIGHWAY SIGNS PUBLICATION" AND THE CURRENT "MANUAL ON UNIFORM TRAFFIC CONTROL DEVICES FOR STREETS AND HIGHWAYS".

(S) DENOTES A SPECIAL SIZE SIGN.

ALL SIGNS SHALL BE OF THE ENCAPSULATED LENS TYPE.

SIGNS

N.T.S.

CD-619-2

NEW JERSEY DEPARTMENT OF TRANSPORTATION

CONSTRUCTION DETAILS

CD-619-2.1



W5 - 1 [36" x 36"]
(9 S.F.)
W5 - 1 (S) [48" x 48"]
(16 S.F.)



W6 - 1 [36" x 36"]
(9 S.F.)
W6 - 1 (S) [48" x 48"]
(16 S.F.)



W8 - 5 [30" x 30"]
(6.3 S.F.)
W8 - 5 (S) [36" x 36"]
(9 S.F.)

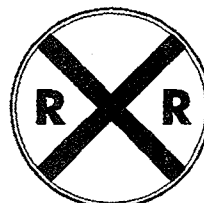

W10 - 1 [36" DIA.]
(7.1 S.F.)



W13 - 1 [18" x 18"]
(2.3 S.F.)
W13 - 1 (S) [24" x 24"]
(4 S.F.)



W14 - 1 [30" x 30"]
(6.3 S.F.)
W14 - 1 (S) [36" x 36"]
(9 S.F.)



W5 - 2 [30" x 30"]
(6.3 S.F.)
W5 - 2 (S) [36" x 36"]
(9 S.F.)



W6 - 2 [36" x 36"]
(9 S.F.)
W6 - 2 (S) [48" x 48"]
(16 S.F.)



(L OR R)
W9 - 1 [36" x 36"]
(9 S.F.)
W9 - 1 (S) [48" x 48"]
(16 S.F.)



W12 - 1 [24" x 24"]
(4 S.F.)
W12 - 1 (S) [30" x 30"]
(6.3 S.F.)

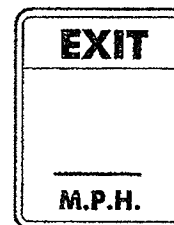

W13 - 2 [48" x 60"]
(20 S.F.)
W13 - 2 (EXPWY) [36" x 48"]
(12 S.F.)
W13 - 2 (S) [24" x 30"]
(5 S.F.)



W14 - 2 [30" x 30"]
(6.3 S.F.)
W14 - 2 (S) [36" x 36"]
(9 S.F.)

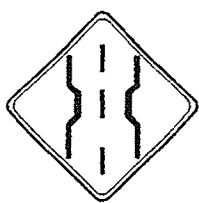

W5 - 2a [30" x 30"]
(6.3 S.F.)
W5 - 2a (S) [36" x 36"]
(9 S.F.)

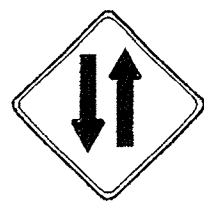

W6 - 3 [30" x 30"]
(6.3 S.F.)
W6 - 3 (S) [36" x 36"]
(9 S.F.)



(L OR R)
W9 - 2 [36" x 36"]
(9 S.F.)
W9 - 2 (S) [48" x 48"]
(16 S.F.)



W12 - 2 [36" x 36"]
(9 S.F.)
W12 - 2 (S) [48" x 48"]
(16 S.F.)

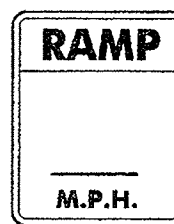

W13 - 3 [48" x 60"]
(20 S.F.)
W13 - 3 (EXPWY) [36" x 48"]
(12 S.F.)
W13 - 3 (S) [24" x 30"]
(5 S.F.)

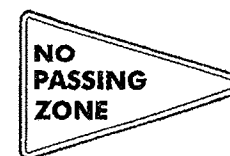

W14 - 3 [36" x 48" x 48"]
(6 S.F.)
W14 - 3 (S) [48" x 64" x 64"]
(10.7 S.F.)

GENERAL NOTES:

DIMENSIONS, COLORS, AND DETAILS OF VARIOUS SIZE SIGNS, SHIELDS AND ACCESSORY PANELS TO FOLLOW STANDARDS IN THE CURRENT "STANDARD HIGHWAY SIGNS PUBLICATION" AND THE CURRENT "MANUAL ON UNIFORM TRAFFIC CONTROL DEVICES FOR STREETS AND HIGHWAYS".

(S) DENOTES A SPECIAL SIZE SIGN.

ALL SIGNS SHALL BE OF THE ENCAPSULATED LENS TYPE.

SIGNS

N.T.S.

CD-619-3

NEW JERSEY DEPARTMENT OF TRANSPORTATION

CONSTRUCTION DETAILS

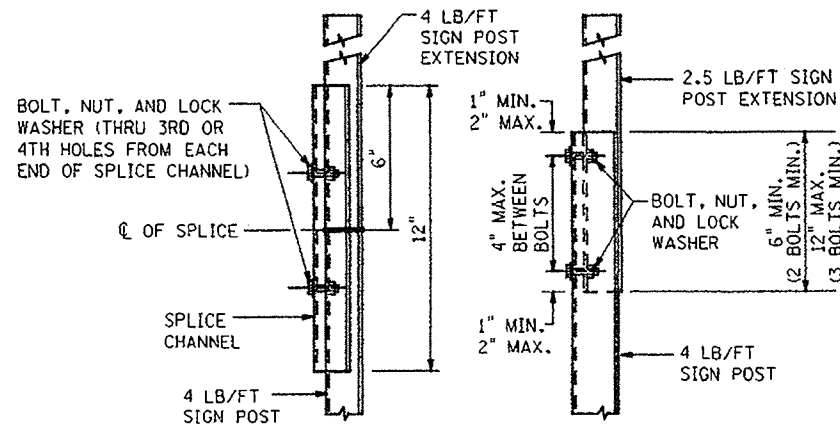

SIGN POST EXTENSION SPLICE DETAILS

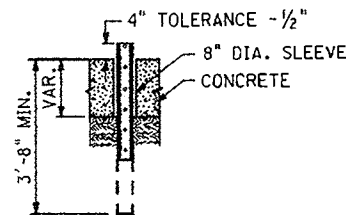

CONCRETE INSTALLATION

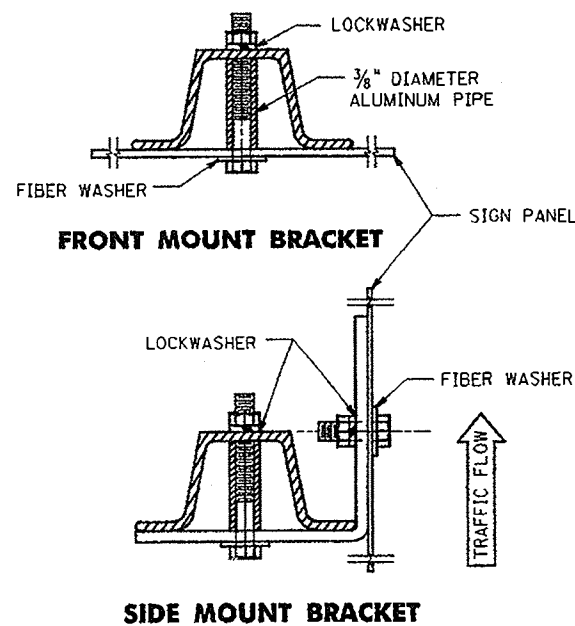

FRONT MOUNT BRACKET

SIDE MOUNT BRACKET

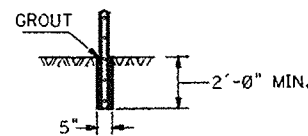

ROCK INSTALLATION

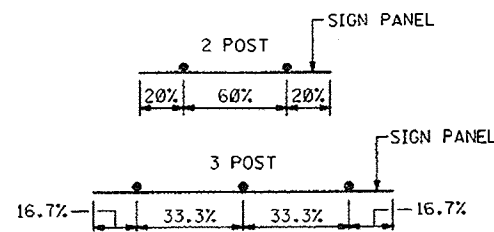

STEEL U-POST SPACING

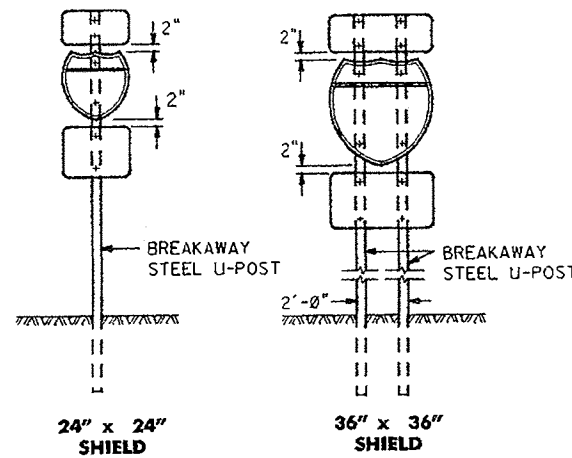

24" x 24" SHIELD

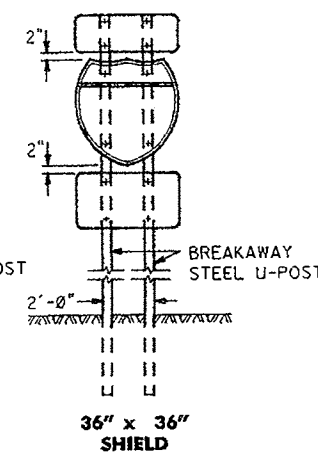

36" x 36" SHIELD

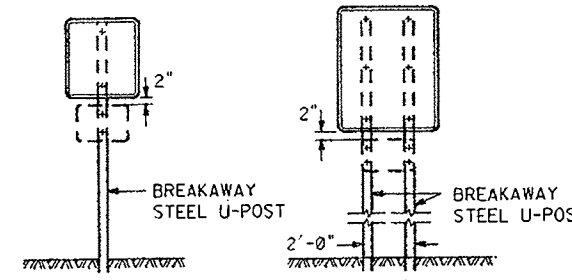

30" x 30" OR SMALLER

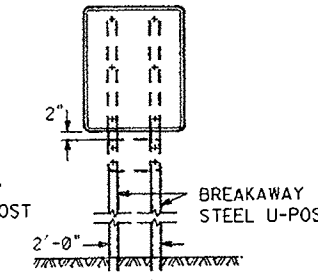

36" x 36" OR LARGER

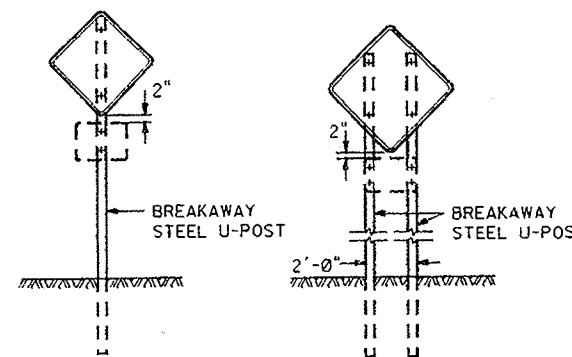

30" x 30" OR SMALLER

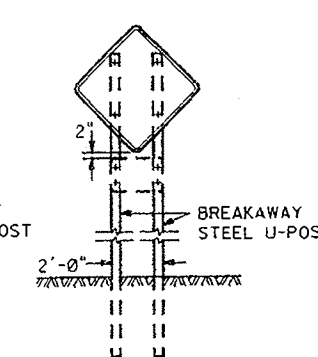

36" x 36" OR LARGER

GENERAL NOTES:

1. ALL POSTS SHALL BE OF ADEQUATE LENGTH TO MEET THE REQUIREMENTS FOR ERECTION AS STATED IN THE CURRENT "MANUAL ON UNIFORM TRAFFIC CONTROL DEVICES FOR STREETS AND HIGHWAYS" AND AS INDICATED BELOW.
2. ALL SMALL SIGN SUPPORTS SHALL BE OF THE BREAKAWAY TYPE WITH EXCEPTION OF THOSE INSTALLED BEHIND GUIDE RAIL OR OTHER ROADSIDE BARRIER.
3. ALL STEEL POSTS AND BRACKETS SHALL BE CUT, BENT, AND HOLES PUNCHED AND DRILLED BEFORE GALVANIZING. GALVANIZING SHALL BE IN CONFORMANCE WITH CURRENT ASTM A123.
4. ALL STEEL U-POST SIGN SUPPORTS MUST BE INSTALLED FACING THE PREDOMINANT TRAFFIC FLOW. A MOUNTING BRACKET SHOULD BE USED ON SIDE MOUNTED SIGNS SUCH AS "ONE WAY" SIGNS INSTALLED IN MEDIANS.
5. SIGN PANEL SIZES SHALL DETERMINE POST TYPE AND NUMBER AS SHOWN ON THIS DETAIL.
6. BOLTS SHALL NOT PROTRUDE MORE THAN 3/4" BEYOND THE NUT WHEN TIGHT, BUT SHALL ENGAGE ALL THREADS IN THE NUT.
7. WHEN SIGNS ARE INSTALLED ON SLOPES 10H:1V OR FLATTER, THE MINIMUM VERTICAL CLEARANCE REQUIREMENTS FOR SIGNS ARE:

FOR SINGLE POST INSTALLATIONS - THE MINIMUM DISTANCE BETWEEN THE EDGE OF THE PAVEMENT AND THE BOTTOM OF ANY PANEL MUST BE 7 FEET, AND THE MINIMUM DISTANCE FROM EDGE OF PAVEMENT TO THE TOP OF ANY SIGN PANEL MUST BE 9 FEET.

FOR MULTI-POST INSTALLATIONS - THE MINIMUM DISTANCE BETWEEN THE EDGE OF PAVEMENT AND THE BOTTOM OF A MAJOR SIGN PANEL MUST BE 7 FEET.

SECONDARY SIGN PANELS (LAND SERVICE HIGHWAYS) - THE MINIMUM DISTANCE BETWEEN THE EDGE OF PAVEMENT AND THE BOTTOM OF A SECONDARY SIGN PANEL IS 6 FEET.

SECONDARY SIGN PANELS (INTERSTATE AND FREEWAYS) - THE BOTTOM OF THE MAJOR SIGN SHALL BE A MINIMUM OF 8 FEET AND THE SECONDARY SIGN PANEL A MINIMUM OF 5 FEET ABOVE THE EDGE OF PAVEMENT.

WHERE GRADING OF 10H:1V OR FLATTER CANNOT BE OBTAINED, OR WHERE CURB OR BERM IS GREATER THAN 4 INCHES, THE MINIMUM VERTICAL CLEARANCE WILL BE MEASURED FROM THE GROUND LINE TO THE BOTTOM OF THE SIGN.

8. PERMANENT SIGN SUPPORTS SHOULD NOT BE INSTALLED ON SLOPES GREATER THAN 10H:1V, EXCEPT WHERE GRADING OF 10H:1V CANNOT BE OBTAINED OR THE SIGN SUPPORTS WILL BE BEHIND A TRAFFIC BARRIER. THE SLOPE SHALL EXTEND A MINIMUM OF 3 FEET BEYOND THE OUTSIDE EDGE OF SIGN (SEE GRADING DETAIL FOR SLOPE TREATMENT).
9. EXTRUDED ALUMINUM SIGN PANELS ARE NOT PERMITTED FOR USE WITH STEEL U-POST SIGN SUPPORTS.
10. STEEL U-POST SIGN SUPPORTS SHALL NOT BE PLACED IN FRONT OF GUIDE RAIL AND THE POSTS MUST NOT STRADDLE GUIDE RAIL.
11. TO EXTEND THE HEIGHT OF A SIGN POST, A MAXIMUM OF ONE SPLICE MAY BE MADE AND MUST BE A MINIMUM OF 9 FEET FROM THE GROUNDLINE TO CENTER LINE OF SPLICE.

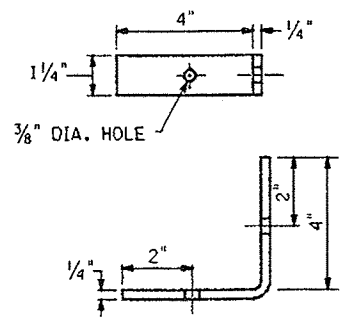

DETAIL OF BRACKET FOR SIDE MOUNTED SIGNS

PANEL SIZE (W x H)	# OF POSTS	POST SIZE (LB/FT)
18" x 18"	1	2.5
18" x 24"	1	2.5
24" x 24"	1	2.5
24" x 30"	1	2.5
24" x 36"	1	2.5
30" x 24"	1	2.5
30" x 30"	1	2.5
36" x 12"	2	2.5
36" x 36" x 36"	2	2.5
30" x 36"	1	4.0

PANEL SIZE (W x H)	# OF POSTS	POST SIZE (LB/FT)
36" x 36"	2	2.5
36" x 48"	2	2.5
45" x 36"	2	2.5
48" x 24"	2	2.5
48" x 36"	2	2.5
48" x 48"	2	4.0
48" x 64" x 64"	2	2.5
60" x 36"	2	4.0
48" x 60"	2	4.0
60" x 30"	2	4.0

**U-POST SELECTION TABLE
BREAKAWAY SIGN SUPPORT**

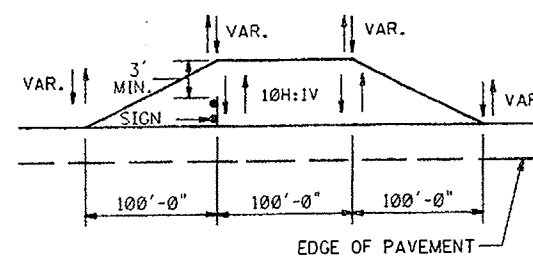

STEEL U-POST GRADING DETAIL

STEEL U-POST SIGN SUPPORTS

N.T.S.

CD-619-4

NEW JERSEY DEPARTMENT OF TRANSPORTATION

CONSTRUCTION DETAILS

STEEL POSTS, POST CLIPS, SPACING, ETC. AND TWO PIECE STEEL U-POSTS.

CD-619-4.1

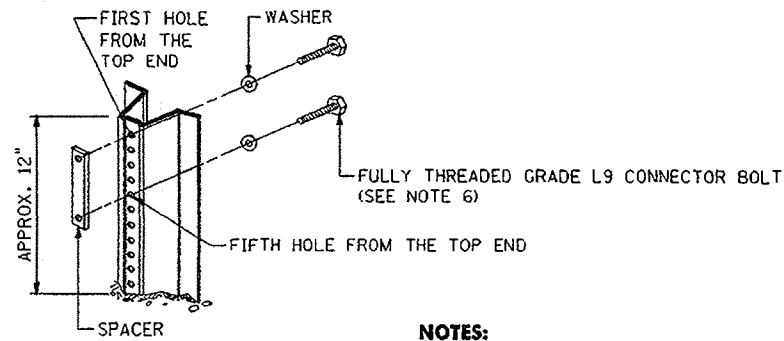

NOTES:

1. DRIVE ANCHOR POST ASSEMBLY TO WITHIN APPROXIMATELY 12 INCHES ABOVE GROUND LEVEL. PLACE BOLT AND WASHER IN FIRST AND FIFTH HOLES FROM THE TOP END, AND SECURELY TIGHTEN BOLTS ONTO THREADED SPACER.
2. DRIVE ANCHOR POST ASSEMBLY TO WITHIN A MAXIMUM OF 4 INCHES ABOVE GROUND LEVEL.
3. DIG OUT AROUND BACK OF ANCHOR POST ASSEMBLY TO ALLOW ROOM FOR TOP POST TO BE ATTACHED.
4. NEST TOP POST ASSEMBLY ONTO PROTRUDING ANCHOR POST ASSEMBLY BOLTS, THROUGH THE FIRST AND FIFTH HOLES FROM THE BOTTOM OF THE TOP POST.
5. PLACE AND TIGHTEN A SELF-LOCKING FLANGE NUT ON EACH BOLT. WHEN INSTALLATION IS COMPLETE, TOP OF GROUND POST SHALL NOT EXCEED 4 INCHES ABOVE GROUND LEVEL.
6. SIZE OF CONNECTOR BOLT FOR TYPE 1, $\frac{5}{16}$ " \times $1\frac{1}{2}$ "
SIZE OF CONNECTOR BOLT FOR TYPE 2, $\frac{5}{16}$ " \times 2"

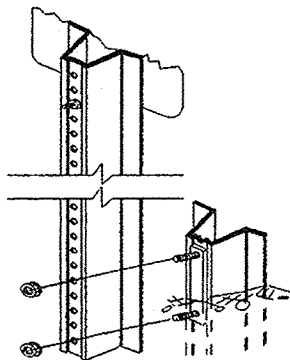
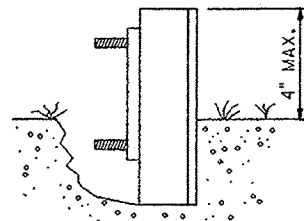

NOTE:

THE CONNECTOR BOLTS AND SPACERS SHALL BE FULLY THREADED. EACH CONNECTOR BOLT AND NUT SHALL BE CLEARLY STAMPED WITH MANUFACTURER'S IDENTIFYING MARK.

**ANCHOR POST ASSEMBLY
SIGN SUPPORTS**

CD-619-5.2

NOTES:

1. ANCHOR POST AND TOP POST SHALL BE OF EQUAL WEIGHT/FEET.
2. SOIL ANCHOR PLATE SHALL BE ATTACHED TO ALL ANCHOR POSTS.
3. THE MATERIAL FOR THE SOIL ANCHOR PLATES SHALL BE CARBON SHEET STEEL.

WEIGHT * LBS./FT.	DIMENSIONS (MM)				AREA IN. ²	X-X AXIS **		Y-Y AXIS	
	"A"	"B"	"C"	"D"		I(IN. ⁴)	S(IN. ³)	I(IN. ⁴)	S(IN. ³)
2.50	1.516	3.062	1.278	0.669	0.760	0.228	0.313	0.539	0.352
4.00	1.968	3.500	1.336	0.834	1.187	0.611	0.707	1.161	0.664

TYPE 1 STEEL U-POST PROPERTIES
* ± 5%
** GOVERNING SECTION

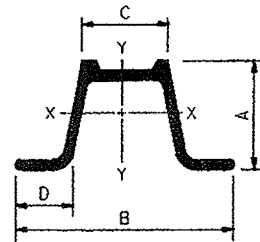

**TYPE 1 STEEL
U-POST**

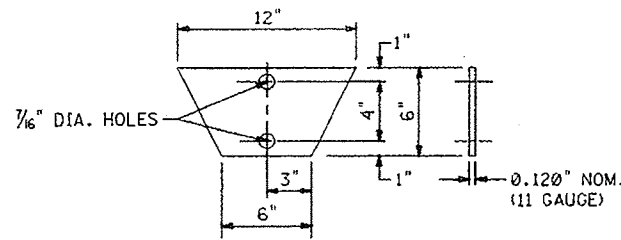

**TYPE 1
SOIL ANCHOR PLATE**

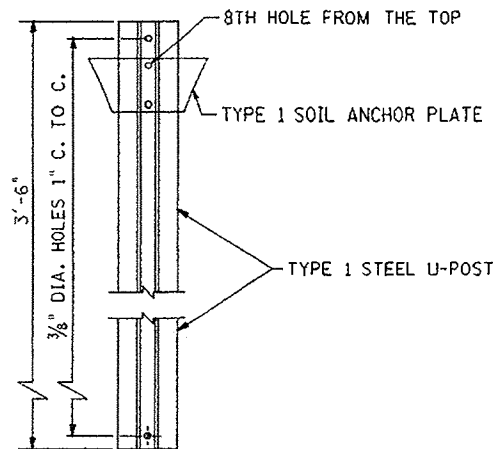

**TYPE 1
ANCHOR POST
ASSEMBLY**

WEIGHT * LBS./FT.	DIMENSIONS (MM)				AREA IN. ²	X-X AXIS **		Y-Y AXIS	
	"A"	"B"	"C"	"D"		I(IN. ⁴)	S(IN. ³)	I(IN. ⁴)	S(IN. ³)
2.50	1.549	3.125	1.250	0.625	0.748	0.233	0.289	0.551	0.353
4.00	1.845	3.500	1.625	0.718	1.190	0.500	0.560	1.190	0.690

TYPE 2 STEEL U-POST PROPERTIES
* ± 5%
** GOVERNING SECTION

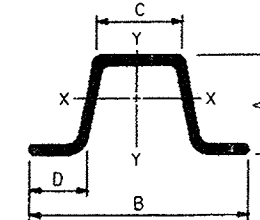

**TYPE 2 STEEL
U-POST**

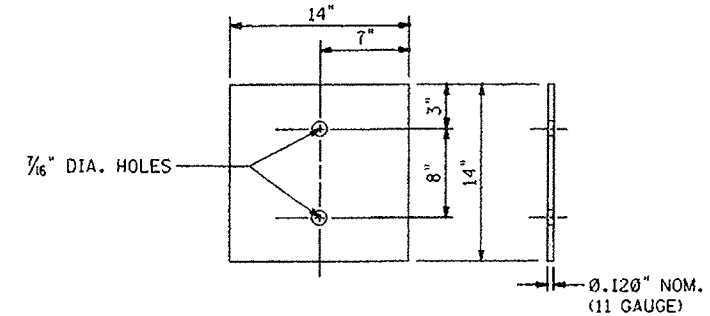

**TYPE 2
SOIL ANCHOR PLATE**

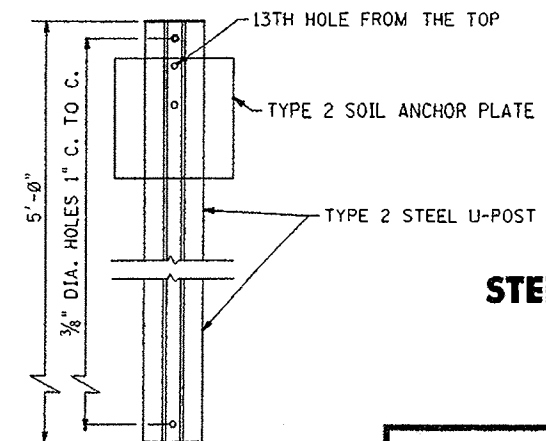

**TYPE 2
ANCHOR POST
ASSEMBLY**

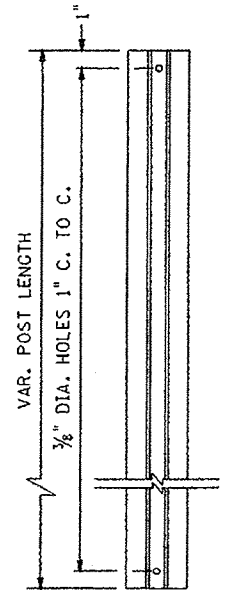

**TOP POST
U-POST**

**STEEL U-POST SIGN
SUPPORTS**

N.T.S.

CD-619-5

NEW JERSEY DEPARTMENT OF TRANSPORTATION

CONSTRUCTION DETAILS

STEEL POSTS, POST CLIPS, SPACING, ETC.
AND TWO PIECE STEEL U-POSTS.

CD-619-5.1

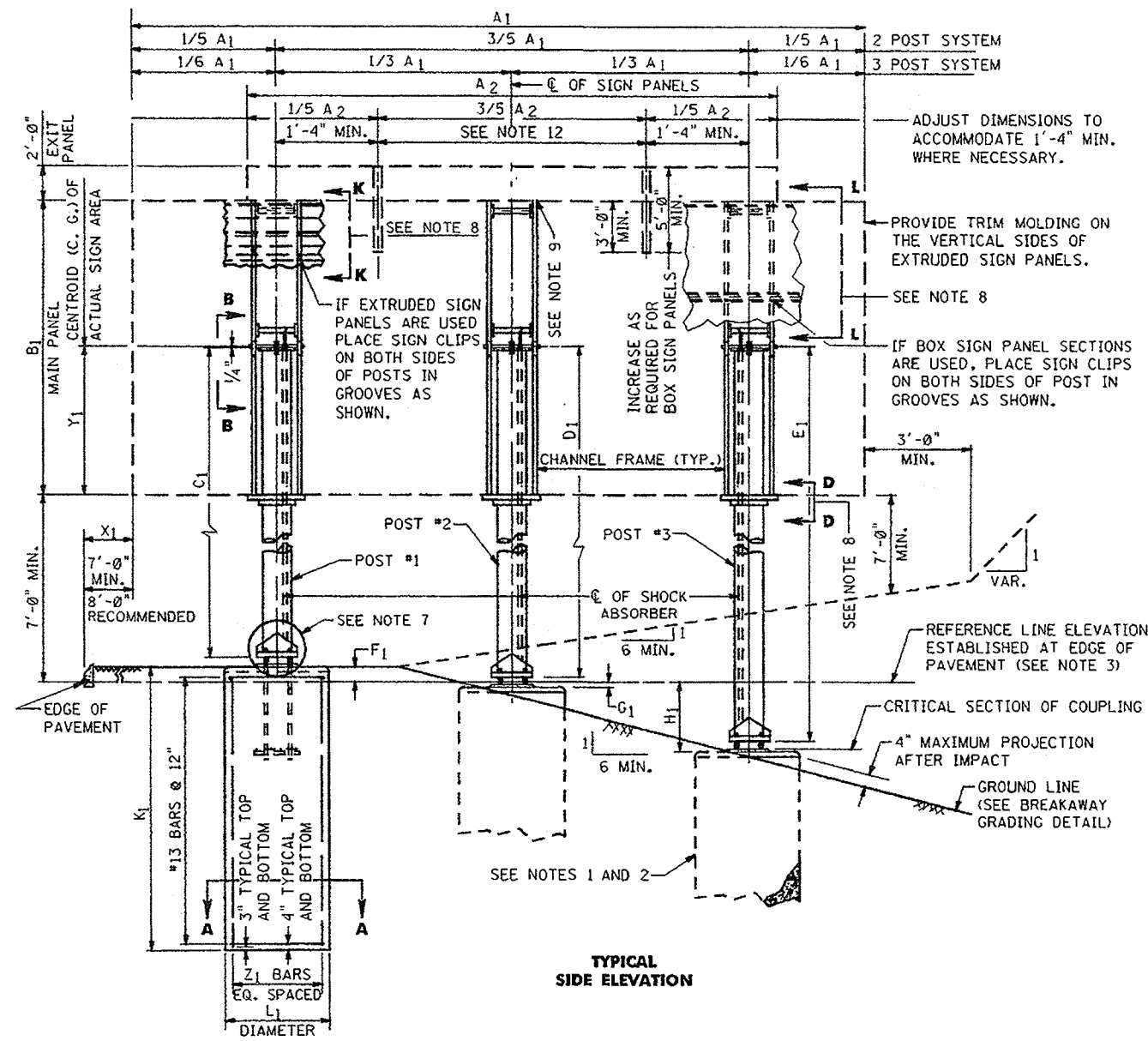

TYPICAL SIDE ELEVATION

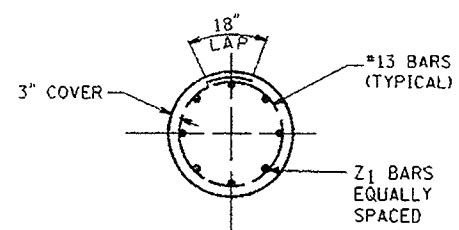

SECTION A-A

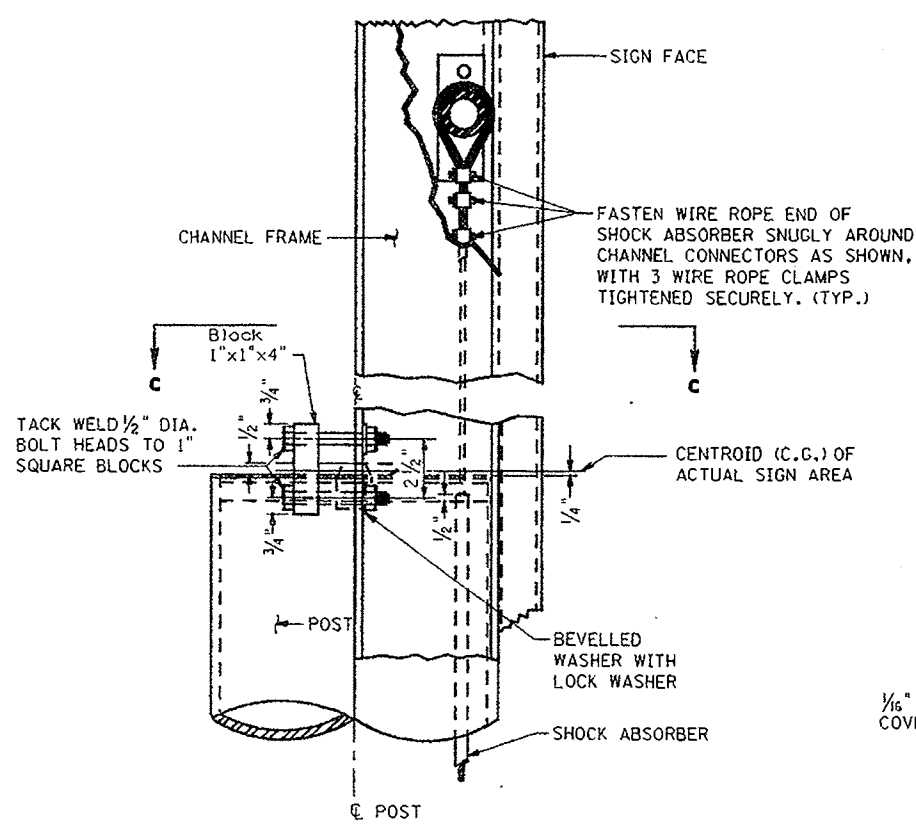

SECTION B-B

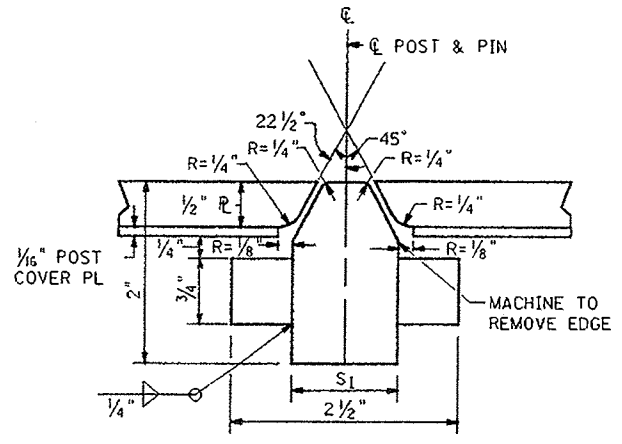

PIN DETAIL

- GENERAL NOTES :**
1. USE CLASS B CONCRETE IN ALL FOOTINGS, AS SPECIFIED IN SECTION 914 OF THE STANDARD SPECIFICATIONS- ($f_c = 3000$ P.S.I.).
 2. ALL FOOTINGS SHALL BE PLACED AGAINST UNDISTURBED EARTH, EXCEPT FOR FOOTING TOPS WHICH SHALL BE FORMED TO A DEPTH OF 3 INCHES BELOW GROUND LINE.
 3. TOPS OF FOOTINGS ABOVE REFERENCE LINE ARE INDICATED BY PLUS (+) VALUE, AND BELOW BY MINUS (-) VALUE.
 4. ALL MATERIAL SHALL BE ALUMINUM ALLOY 6061-T6 UNLESS OTHERWISE NOTED.
 5. NUTS, BOLTS AND FLAT WASHERS SHALL BE MADE FROM ALUMINUM ALLOY ALCLAD 2024-T4. SPRING LOCK WASHERS SHALL BE MADE FROM ALUMINUM ALLOY 7075-T6.
 6. WELDING OF ALUMINUM SHALL BE AS SPECIFIED IN THE CONSTRUCTION SPECIFICATIONS.
 7. FOR DETAIL OF POST BASE AND INSTALLATION REFER TO "BREAKAWAY SIGN SUPPORTS FOR GROUND MOUNTED SIGNS-CD-619-9".
 8. FOR DETAILS OF SECTIONS "C-C", "D-D", "K-K" AND "L-L" REFER TO "BREAKAWAY SIGN SUPPORTS FOR GROUND MOUNTED SIGNS-CD-619-8".
 9. SIGNS WITHOUT EXIT PANELS OR SIGNS WITH PARTIAL WIDTH EXIT PANELS SHALL BE PROVIDED WITH CHANNEL FRAMES EXTENDING TO THE TOP OF THE MAIN PANEL AS SHOWN. CHANNEL FRAMES SHALL BE EXTENDED TO THE TOP OF THE EXIT PANEL WHEN FULL WIDTH EXIT PANELS ARE EMPLOYED.
 10. UNUSUAL FOUNDATION CONDITIONS MAY REQUIRE RE-DESIGNING OF FOOTINGS AND SUCH CONDITIONS SHALL BE BROUGHT TO THE ATTENTION OF THE ENGINEER.
 11. FOR Z_1 , L_1 & K_1 , REFER TO CD-619-12 "SIGN SUPPORT DATA TABLE".
 12. PROVIDE 4C 5.4 FOR PARTIAL WIDTH EXIT PANELS ONLY. USE CONNECTION DETAILS AS EMPLOYED FOR CHANNEL FRAME.
 13. FOR S_1 , SEE CD-619-8.

NOTES:
REINFORCING BARS ARE IN METRIC UNITS.

BREAKAWAY SIGN SUPPORTS FOR GROUND MOUNTED SIGNS

N. T. S.

CD-619-7

NEW JERSEY DEPARTMENT OF TRANSPORTATION

CONSTRUCTION DETAILS

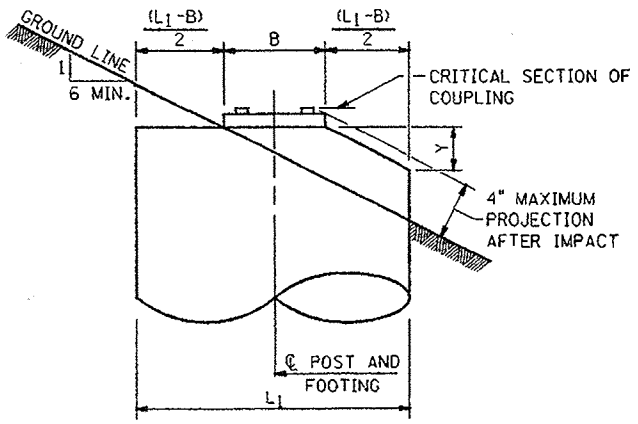

FOOTING BEVEL DETAIL

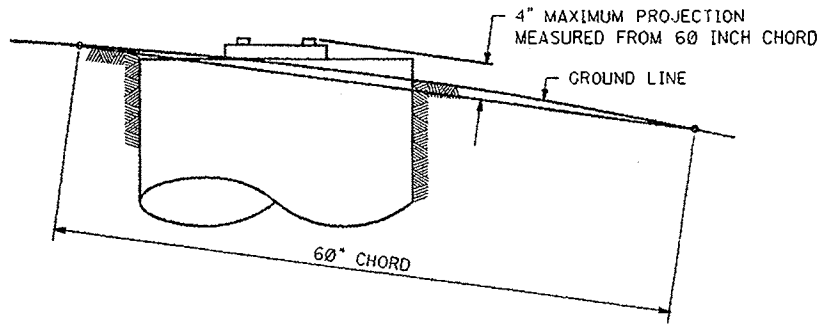

FOOTING/STUB PROJECTION DETAIL

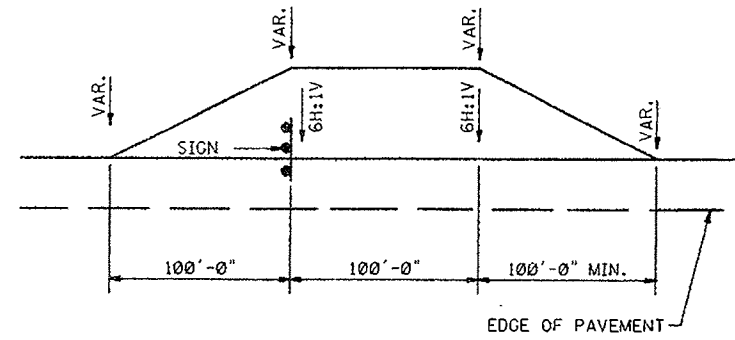

BREAKAWAY GRADING DETAIL

CD-619-7.1

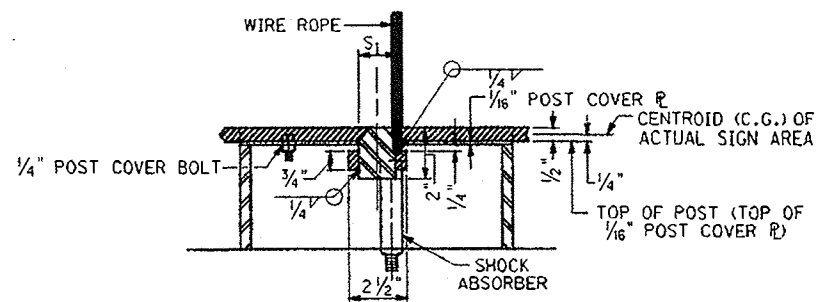

SECTION E-E

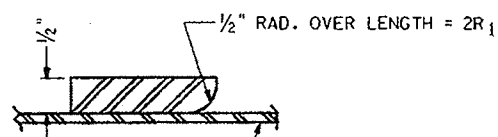

SECTION J-J

BASE TYPE	ALL DIMENSIONS IN IN.		
	N ₁	P ₁	S ₁
2	1 1/8	1 1/8	1
3	1 1/2	1 1/2	1 1/4
4	1 3/8	1 3/4	1 3/8
5	2	2 1/4	1 1/2

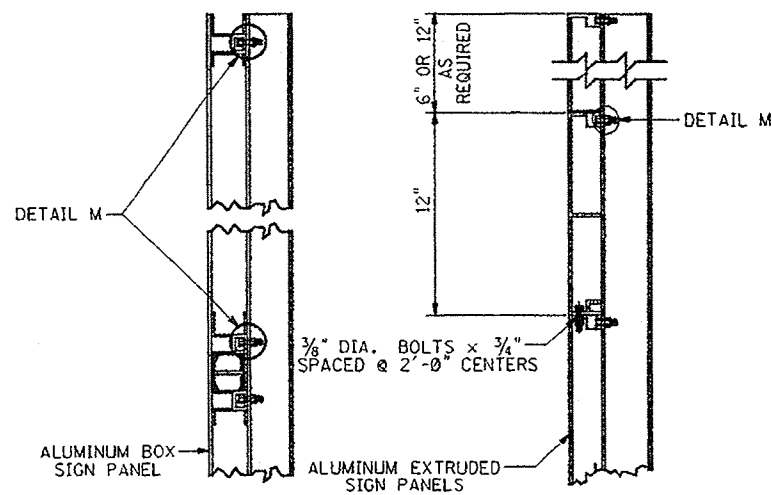

SECTION L-L

SECTION K-K

(EXIT PANEL NOT SHOWN IN SECTIONS L-L & K-K)

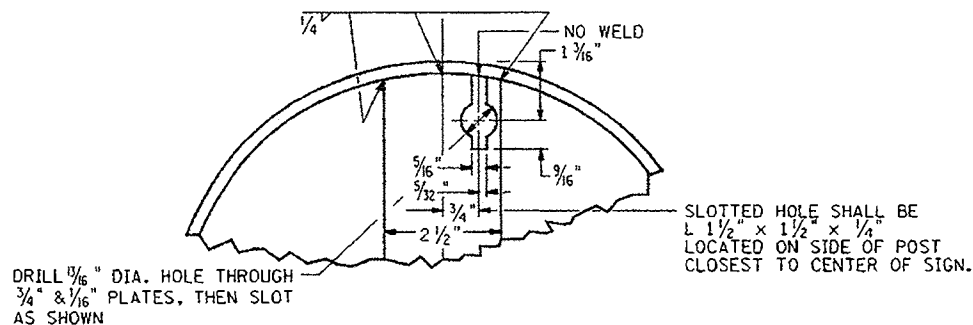

DETAIL - R

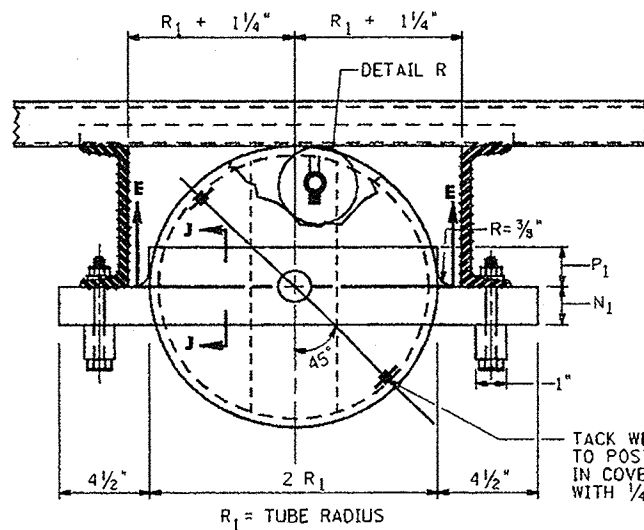

SECTION C-C

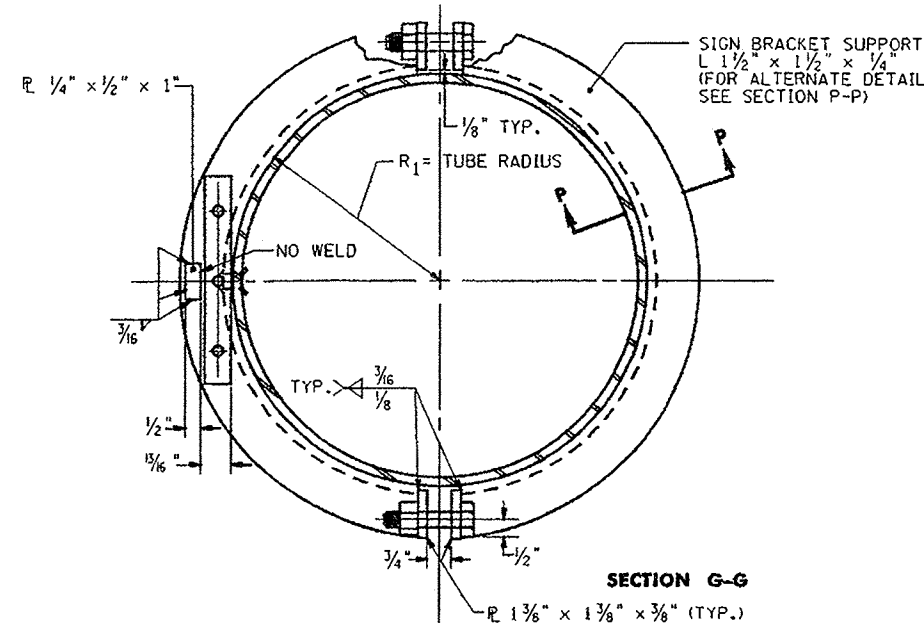

SECTION G-G

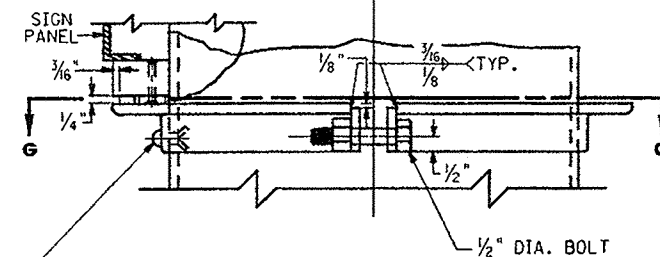

SECTION D-D

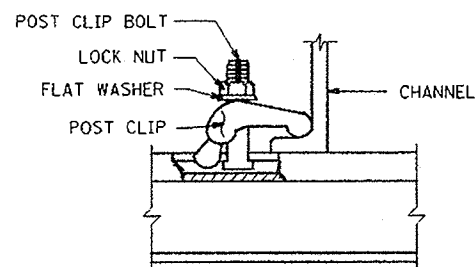

DETAIL - M
SIGN ATTACHMENT

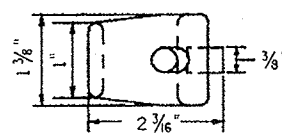

PLAN

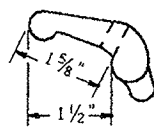

ELEVATION
POST CLIP

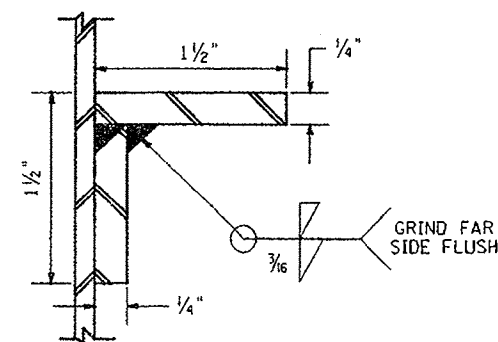

SECTION P-P
(ALTERNATE DETAIL)

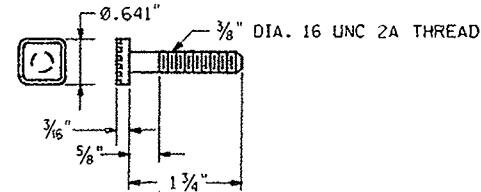

POST CLIP BOLT

BREAKAWAY SIGN SUPPORTS FOR GROUND MOUNTED SIGNS N.T.S.

CD-619-8

NEW JERSEY DEPARTMENT OF TRANSPORTATION

CONSTRUCTION DETAILS

CD-619-8.1

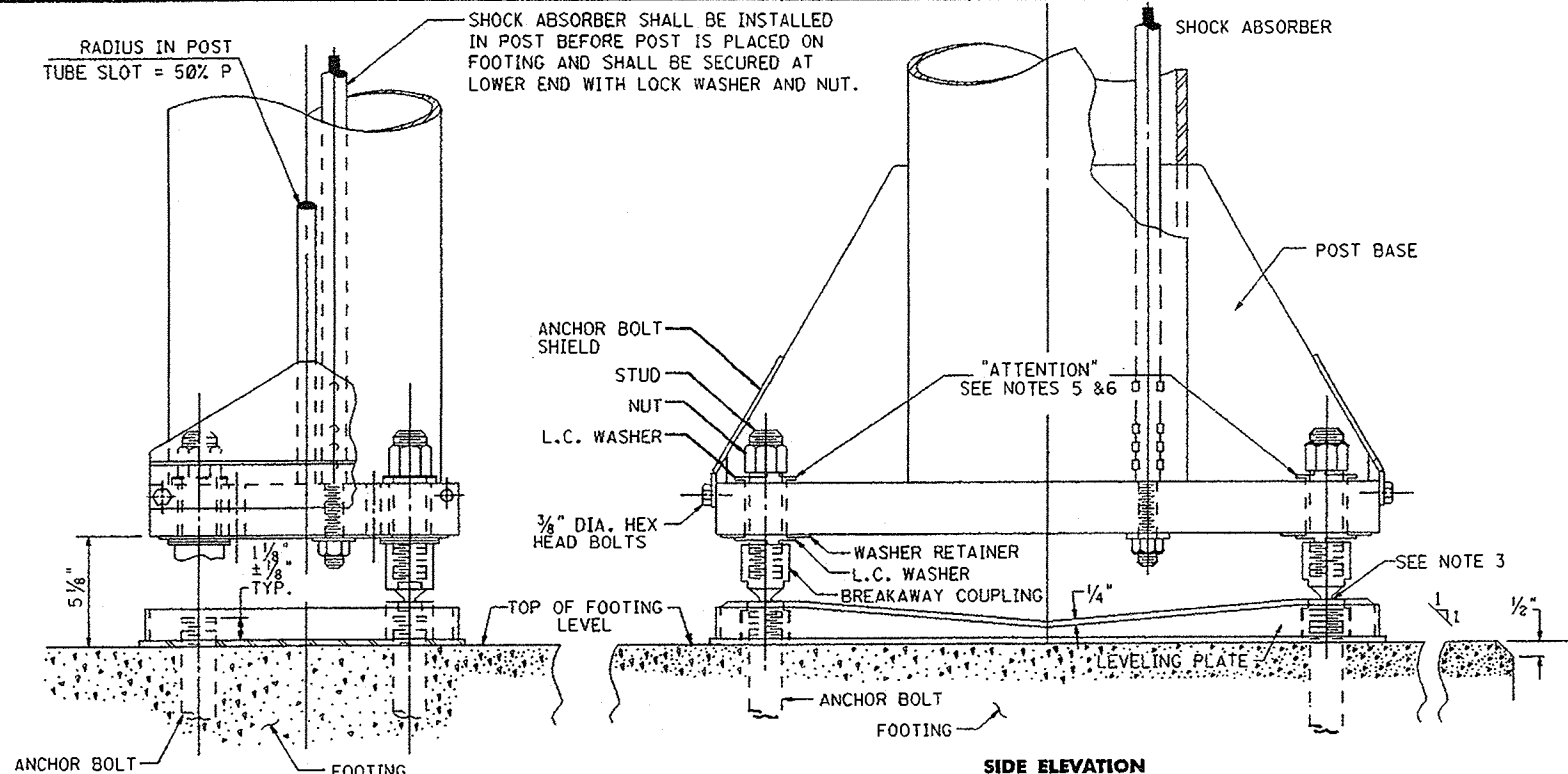

BREAKAWAY COUPLING INSTALLATION

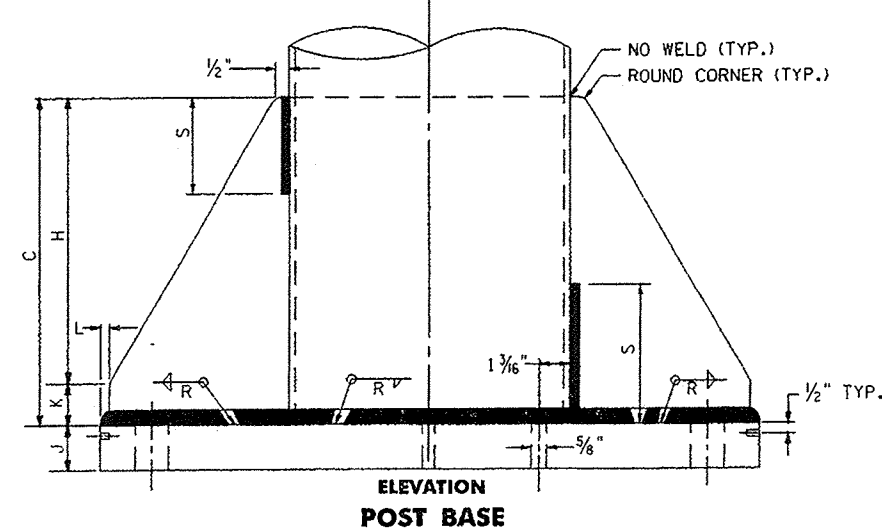
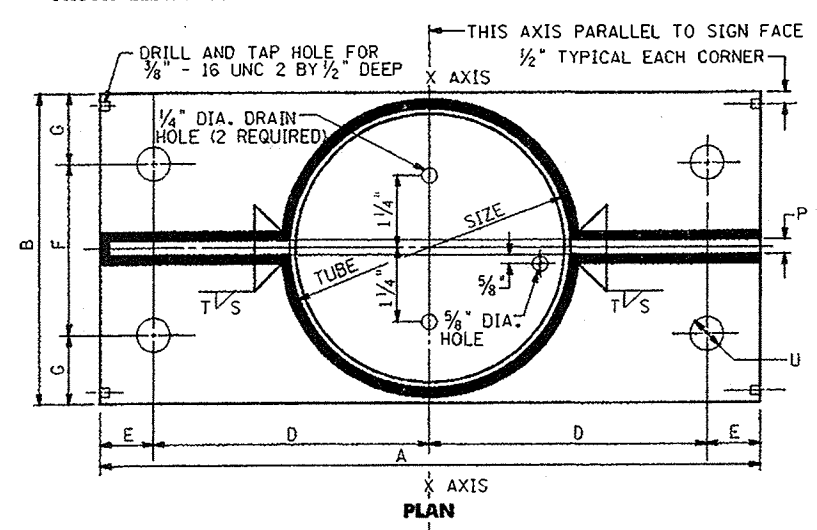

ELEVATION POST BASE

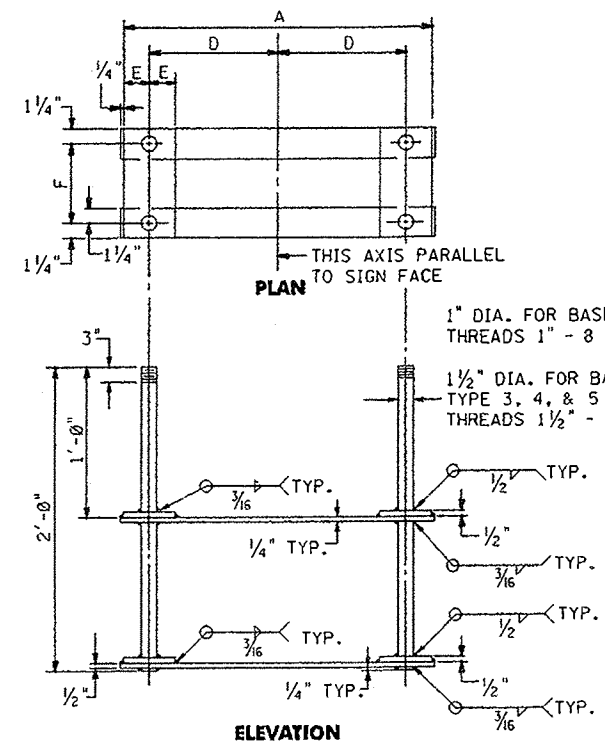

ANCHOR BOLT DETAIL

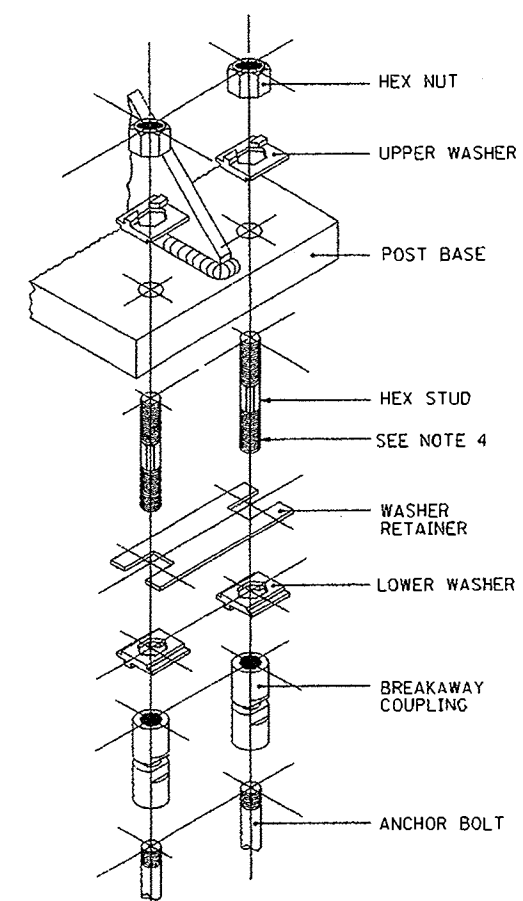

BREAKAWAY COUPLING ASSEMBLY (TYPICAL)

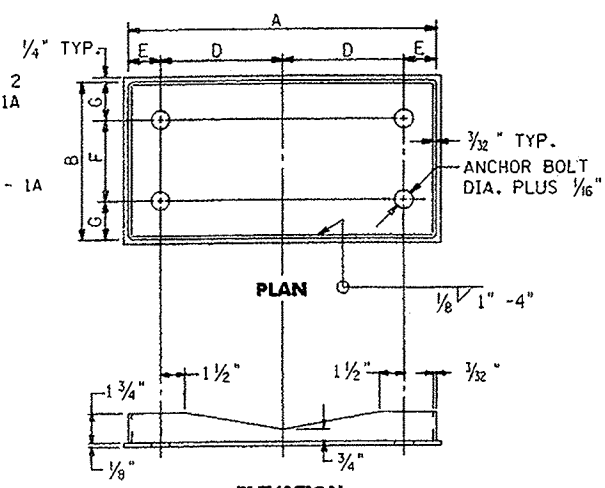

ELEVATION LEVELING PLATE DETAIL

- GENERAL NOTES:**
1. ANCHOR BOLT ASSEMBLY & LEVELING PLATE SHALL BE STRUCTURAL STEEL CONFORMING TO ASTM SPECIFICATION A36 OR EQUIVALENT WITH MINIMUM YIELD STRENGTH OF 36,000 PSI., NUTS, WASHERS AND BOLTS SHALL BE HOT DIP GALVANIZED. TOP 3" OF ALL ANCHOR BOLTS SHALL BE THREADED.
 2. THE CONCRETE FOOTINGS FOR BREAKAWAY SIGNS SHALL BE POURED TO WITHIN APPROXIMATELY 1" OF THE BOTTOM OF THE LEVELING PLATE. THE LEVELING PLATE SHALL BE PLACED ON TOP, SET TO THE PROPER ELEVATION AND MADE COMPLETELY LEVEL. THE ANCHOR BOLTS AND LEVELING PLATE CAN BE PROPERLY POSITIONED.
 3. THE BREAKAWAY COUPLINGS SHALL BE SCREWED TO THE ANCHOR BOLTS, WITH CARE TAKEN THAT THE SMALLER END OF THE TAPER POINTS DOWNWARD. WHILE TIGHTENING THE COUPLINGS TO THE ANCHOR BOLTS, ONLY THE LOWER SET OF WRENCHING FLATS SHALL BE USED.
 4. THE HEX STUD END WITH THE SMALLER THREAD DEPTH (1 1/8") SHALL BE SCREWED INTO TOP OF BREAKAWAY COUPLING.
 5. THE PROPER WASHER NUMBER (STAMPED ON WASHER) MUST BE USED FOR EACH POST AS INDICATED ON CD-619-12, "SIGN SUPPORT DATA TABLE".
 6. RAISED PORTION OF LC WASHERS MUST BE POSITIONED AS INDICATED. CENTER OF RAISED PORTION MUST BE TOWARD 1/4" OF POST.
 7. WASHER RETAINERS SHALL BE PLACED IN THE GROOVES OF THE LC WASHER, AS SHOWN. IT MAY BE NECESSARY TO BACK OFF ON EACH STUD A MAXIMUM OF 30 DEGREES TO ALLOW THE WASHER RETAINER TO FIT.
 8. THE POST BASE SHALL BE PLACED OVER THE STUDS ON TOP OF THE WASHER RETAINERS, AFTER WHICH THE TOP WASHER SHALL BE PLACED OVER EACH HEX STUD. AGAIN, IT IS IMPORTANT THAT THE RAISED PORTION OF THE WASHER CONTACT THE LOWER SURFACE OF THE NUT WHEN IT IS TIGHTENED ON THE STUD AND THAT THE ARROW, APPEARING ON THE TOP SURFACE OF THE WASHER, POINT TOWARD THE CENTERLINE OF THE POST.
 9. THE HEAVY HEX NUT SHALL BE PLACED ON EACH HEX STUD AND TIGHTENED HOLDING THE UPPER WRENCHING FLATS OF THE COUPLING. THESE NUTS SHALL BE TIGHTENED BY THE TURN OF NUT METHOD.

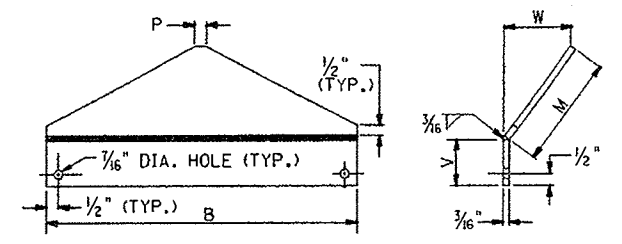

ANCHOR BOLT SHIELD (BENT PLATE MAY BE USED)

BREAKAWAY SIGN SUPPORTS FOR GROUND MOUNTED SIGNS
N.T.S.

BASE TYPE	POST BASE DATA																		
	**A	**B	C	**D	**E	**F	**G	H	**J	K	L	M	P	R	S	**T	U	**V	W
2	13 1/4	7 1/2	9 1/4	5	1 3/8	4	1 3/4	7	1 1/4	1	1/4	5 1/2	1/2	3/8	3 1/2	3/8	1 1/4	1	1 1/8
3	18	9 1/2	12	7	2	5	2 1/4	9 1/8	1 1/2	1 3/8	1/2	6 1/2	5/8	1/2	4 3/4	1/2	1 3/4	1 1/4	2 5/8
4	22	11 1/2	12 3/4	9	2	6	2 3/4	9 1/2	1 3/4	1 1/2	1/2	5	5/8	5/8	10 3/8	3/8	1 3/4	1 3/8	2 1/2
5	28	13 1/2	15	12	2	7	3 1/4	11 1/4	2	1 3/4	1/2	5	3/4	1/2	12 1/2	3/8	1 3/4	2	3 1/8

* THE BASE PLATE THICKNESS "J" MUST CORRESPOND EXACTLY WITH THE BASE TYPE AS SHOWN IN THE TABLE ABOVE. SUBSTITUTION OF ANY OTHER BASE PLATE THICKNESS IS NOT PERMITTED.
** SAFETY DESIGNED ITEMS.

CD-619-9.1

NEW JERSEY DEPARTMENT OF TRANSPORTATION

CONSTRUCTION DETAILS

CD-619-9

ID #
 file #
 date #
 sheet #
 pen table # /
 queue #
 BR2002-1 - ORIGINAL SHEET

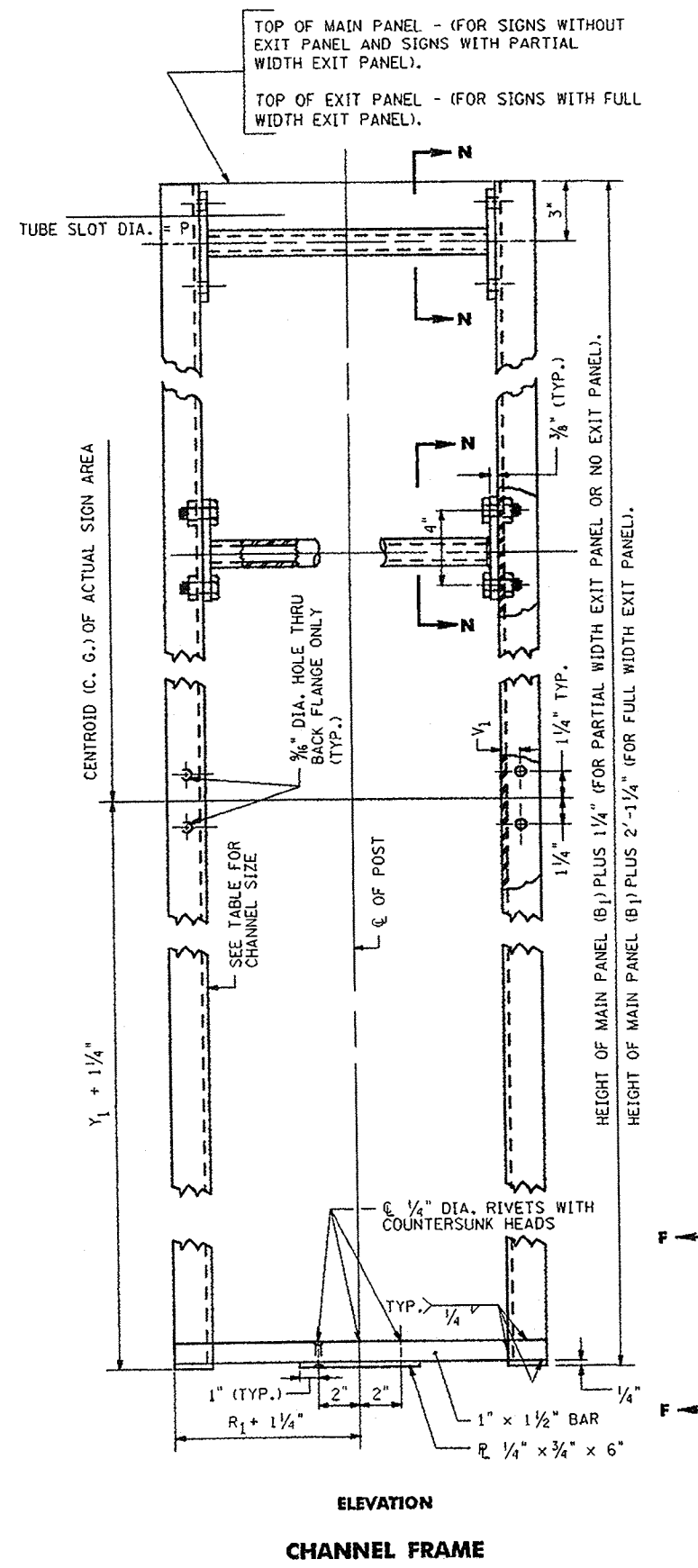

ELEVATION
CHANNEL FRAME

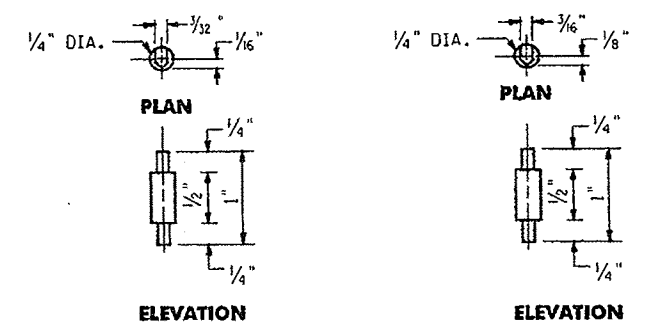

CUTTING PIN DETAIL
BASE TYPE 2 **CUTTING PIN DETAIL**
BASE TYPES 3, 4 & 5

BASE TYPE	CHANNEL SIZE	V ₁ IN
2	3C1.42	3/8
3	4C2.50	1
4	5C3.11	1 1/8
5	6C2.83	1 1/8

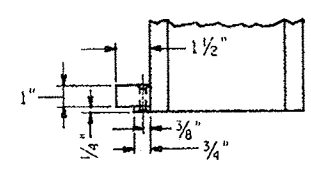
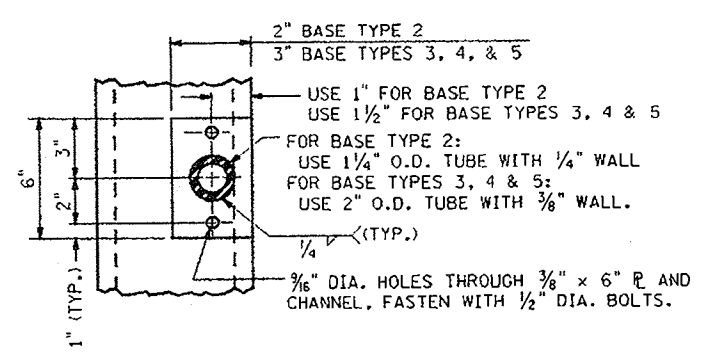

SECTION N-N

VIEW F-F

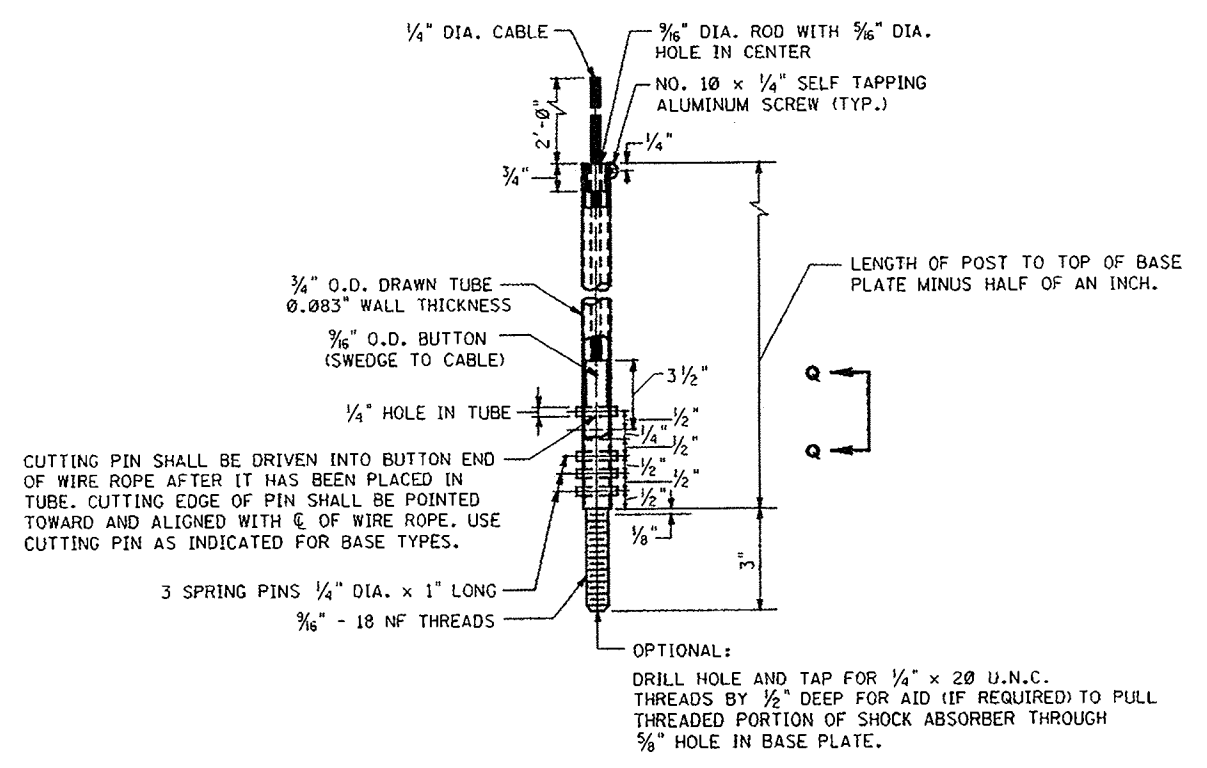

SHOCK ABSORBER

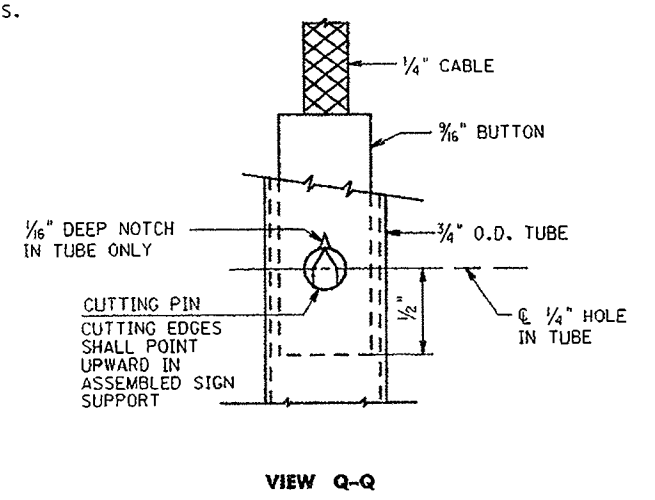

BREAKAWAY SIGN SUPPORTS
FOR GROUND MOUNTED SIGNS

N.T.S. CD-619-10

NEW JERSEY DEPARTMENT OF TRANSPORTATION

CONSTRUCTION DETAILS

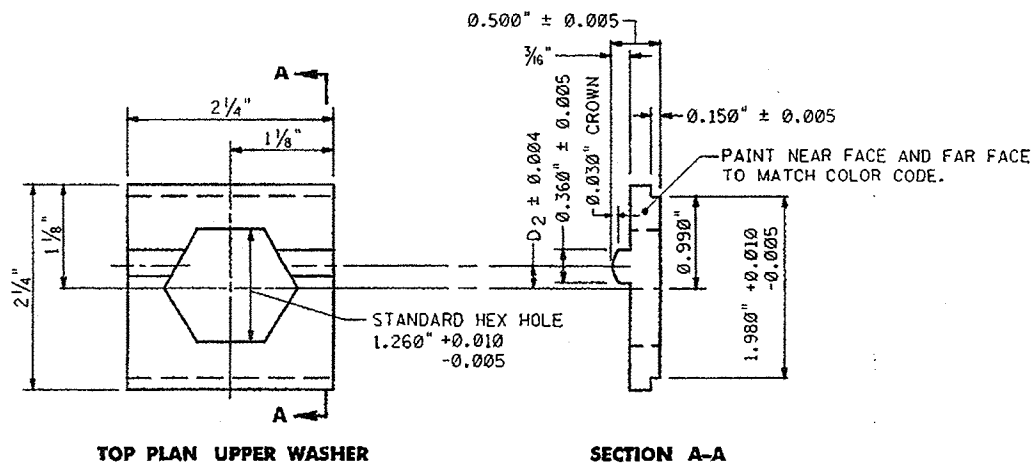

TOP PLAN UPPER WASHER

SECTION A-A

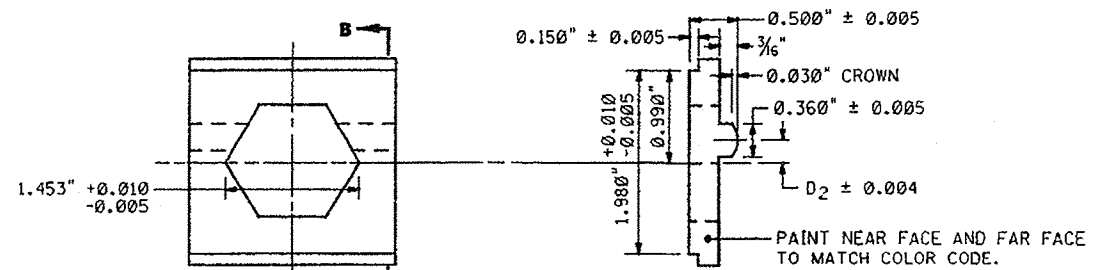

TOP PLAN LOWER WASHER

SECTION B-B

LOAD CONCENTRATING WASHER DETAIL

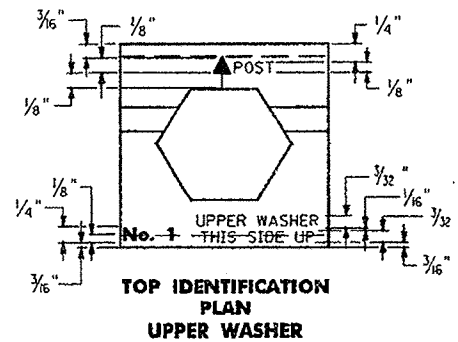

TOP IDENTIFICATION PLAN UPPER WASHER

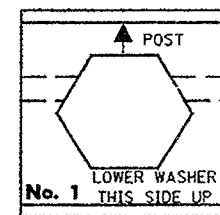

TOP IDENTIFICATION PLAN LOWER WASHER

LOAD CONCENTRATING WASHER IDENTIFICATION DETAIL

WASHER NUMBER	D ₂ INCHES	FACE COLOR CODE
1	0.100	ORANGE
2	1.150	YELLOW
3	0.200	BLUE
4	0.250	GREEN

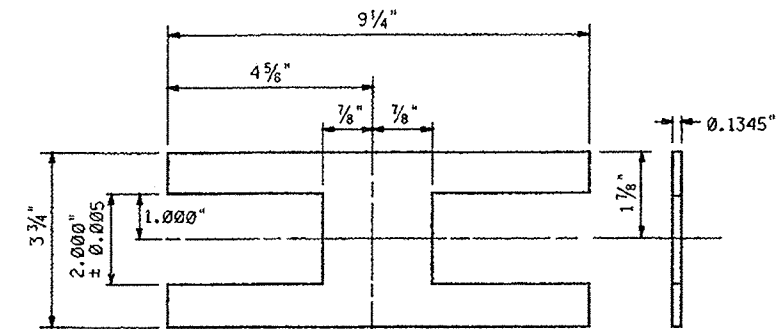

WASHER RETAINER

NOTE:
 ALL LOAD CONCENTRATING WASHERS SHALL BE PERMANENTLY LABELED WITH APPROPRIATE WASHER NUMBER AND IDENTIFICATION AS SHOWN

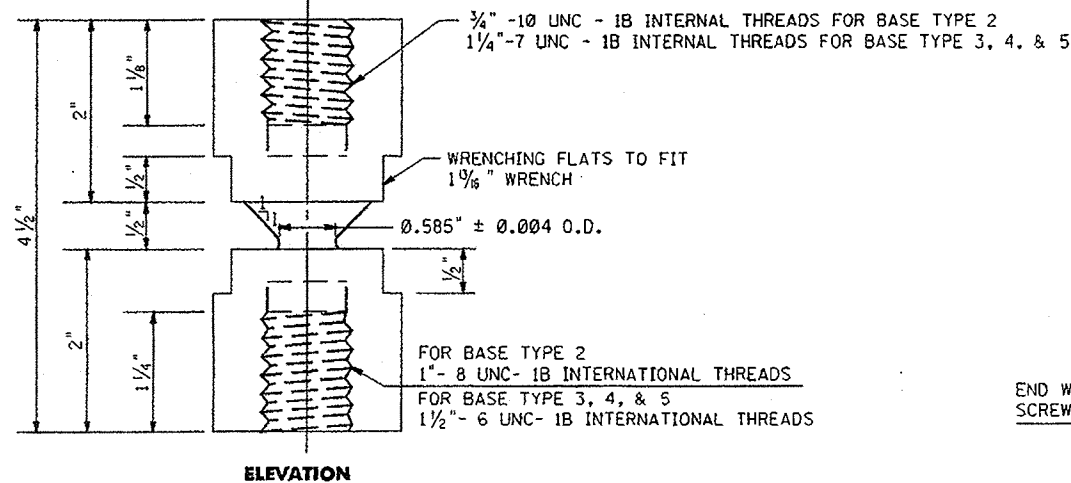
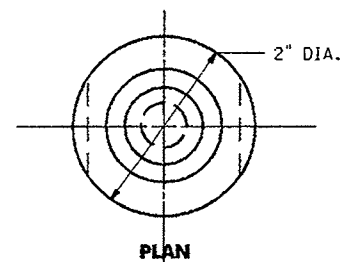

BREAKAWAY COUPLING *

* SHOWN FOR INFORMATION ONLY. COUPLINGS SHALL BE SUPPLIED BY N.J.D.O.T.

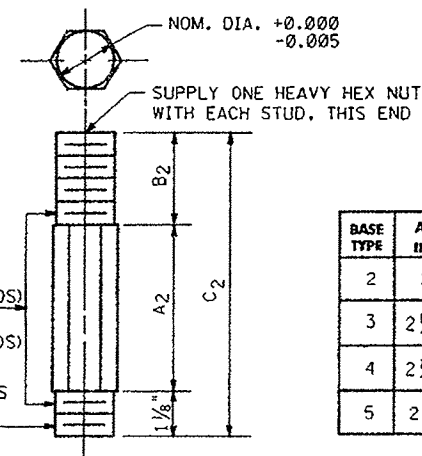

FOR BASE TYPE 2
 3/4" - 10 UNC - 1A THREADS (BOTH ENDS)
 FOR BASE TYPE 3, 4, & 5
 1 1/4" - 7 UNC - 1A THREADS (BOTH ENDS)

END WITH THE SHORTER THREAD DEPTH (1 1/8") IS SCREWED INTO TOP OF BREAKAWAY COUPLING

HEX STUD LENGTHS & SIZES

BASE TYPE	A ₂ IN.	B ₂ IN.	C ₂ IN.	HEX SIZE
2	2	1 1/2	4 3/4	3/4
3	2 1/4	2 1/8	5 1/2	1 1/4
4	2 1/2	2 1/8	5 3/4	1 1/4
5	2 3/4	2 1/8	6	1 1/4

BREAKAWAY SIGN SUPPORTS FOR GROUND MOUNTED SIGNS

N.T.S.

CD-619-11

NEW JERSEY DEPARTMENT OF TRANSPORTATION

CONSTRUCTION DETAILS

CD-619-11.1

pen table = roadautoadv_plytbl/half-scale.tbl
 scale =
 queue =
 dots =
 file =

SIGN SUPPORT DATA TABLE

NO.	STATION	OFFSET X ₁	SIGN SIZE				C.G. SIGN Y ₁	NO. OF POSTS	TUBE SIZE		POST HEIGHT			BASE TYPE	DIMENSIONS TO TOP OF FOOTING			FOOTING DIMENSIONS			REINF. STEEL	L. C. WASHER NUMBER					
			A ₁	B ₁	A ₂	Y ₁			O.D.	THK.	C ₁	D ₁	E ₁		F ₁	G ₁	H ₁	K ₁	L ₁	Z ₁		POST #1	POST #2	POST #3			

FOOTING BEVEL TABLE

IDENT. NO.	(L ₁ - B) 2	Y		
		POST #1	POST #2	POST #3

GENERAL NOTES:

- 1. AN ASTERISK (*) IN COLUMN L₁ INDICATES THAT THE EXPOSED EDGE OF FOOTING MUST BE BEVELLED TO MEET THE 4 INCH MAXIMUM PROJECTION REQUIREMENT.
- 2. LOAD CONCENTRATING WASHER FACE COLOR CODE SHALL BE AS FOLLOWS:
 L.C. WASHER * 1 ORANGE
 L.C. WASHER * 2 YELLOW
 L.C. WASHER * 3 BLUE
 L.C. WASHER * 4 GREEN
- 3. FOR IDENTIFICATION OF TABULAR ITEMS AND DETAILS RELATING THERETO, REFER TO BREAKAWAY SIGN SUPPORTS FOR GROUND MOUNTED SIGNS (CD-619-7)

NOTE TO DESIGNER:
 THIS SHEET REQUIRES DESIGN SPECIFIC INFORMATION TO BE ADDED AND INCLUDED IN THE CONTRACT PLANS.
 REMOVE THIS NOTE AFTER DESIGN SPECIFIC INFORMATION IS ADDED.

BREAKAWAY SIGN SUPPORTS FOR GROUND MOUNTED SIGNS

NEW JERSEY DEPARTMENT OF TRANSPORTATION

CONSTRUCTION DETAILS

CD-619-12

CD-619-12.1

BROD82-1 - ORIGINAL SHEET

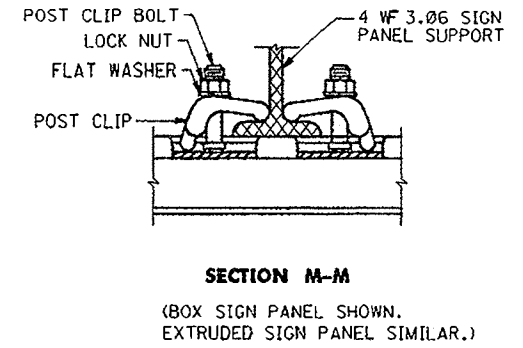
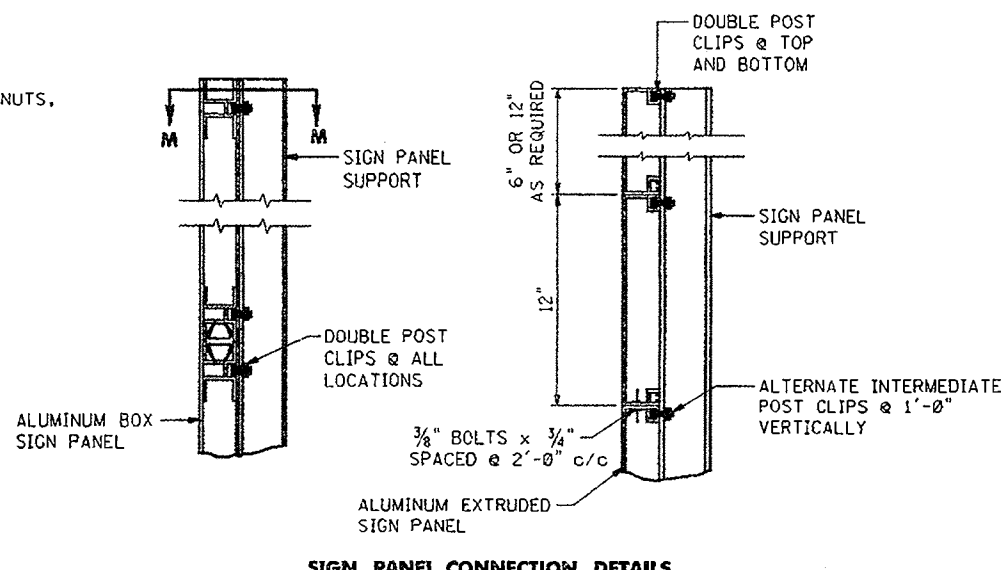
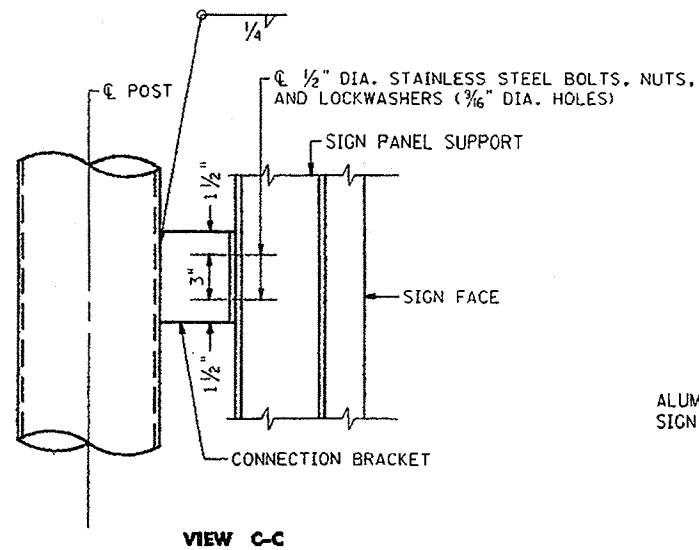
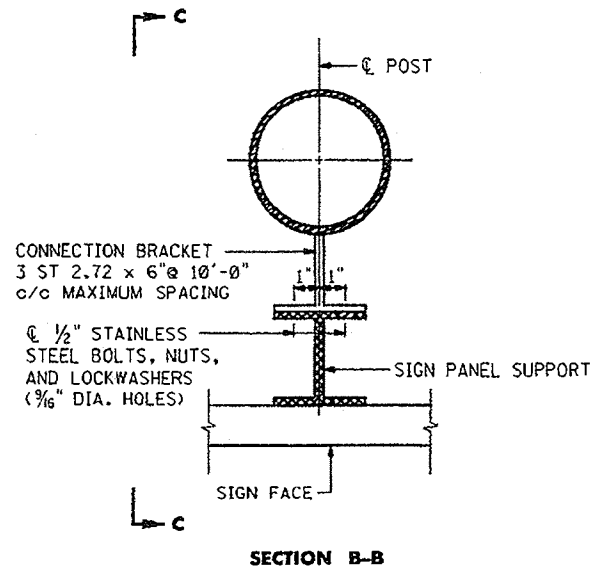

GENERAL NOTES:

1. USE CLASS "B" CONCRETE IN ALL FOOTINGS. ULTIMATE COMPRESSIVE STRENGTH $f'_c = 3,000$ p.s.i.
2. ALL FOOTINGS SHALL BE PLACED AGAINST UNDISTURBED OR ADEQUATELY COMPACTED EARTH. EXCEPT FOR FOOTING TOPS WHICH SHALL BE FORMED TO A DEPTH OF 3 INCHES BELOW GROUND LINE.
3. TOPS OF FOOTINGS ABOVE REFERENCE LINE ARE INDICATED BY PLUS (+) VALUE; AND BELOW REFERENCE LINE BY MINUS (-) VALUE.
4. MATERIAL FOR STRUCTURAL SHAPES AND PLATES SHALL BE ALUMINUM ALLOY 6061-T6.
5. ANCHOR BOLT ASSEMBLY SHALL BE STRUCTURAL STEEL CONFORMING TO ASTM SPECIFICATION F1554 WITH MINIMUM YIELD STRENGTH OF 36,000 p.s.i. NUTS, WASHERS AND BOLTS SHALL BE HOTDIP GALVANIZED CONFORMING TO ASTM A153 CLASS C. THE TOP 6 INCHES OF ALL ANCHOR BOLTS SHALL BE THREADED.
6. WELDING OF ALUMINUM SHALL BE AS SPECIFIED IN THE CONSTRUCTION SPECIFICATIONS.
7. UNUSUAL FOUNDATION CONDITIONS MAY REQUIRE REDESIGN OF FOOTING AND SUCH CONDITIONS SHALL BE BROUGHT TO THE ATTENTION OF THE ENGINEER.
8. DIMENSIONS FOR BASE TYPE A ARE DESIGNATED (A). DIMENSIONS FOR BASE TYPE B ARE DESIGNATED (B).
9. PROVIDE 4 WF 3.06 EXIT PANEL BRACE FOR PARTIAL WIDTH EXIT PANELS ONLY.

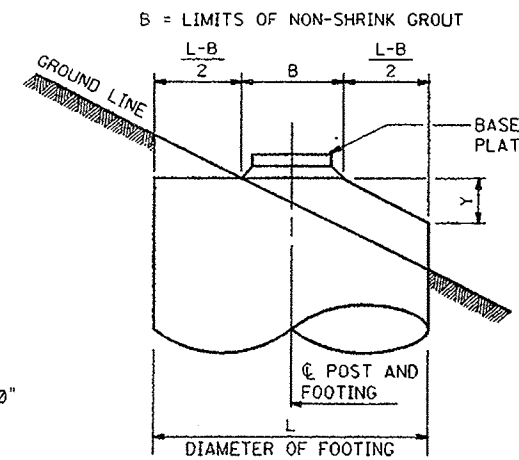

FOOTING BEVEL DETAIL (BEND REINFORCEMENT TO FIT)

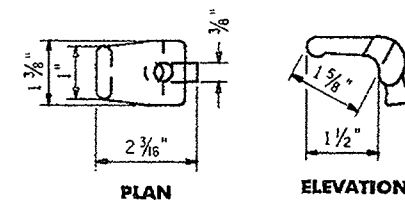

POST CLIP

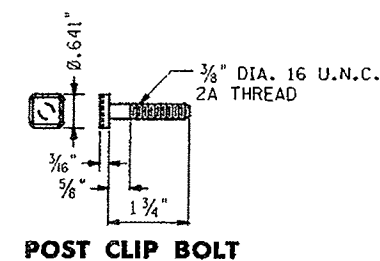

POST CLIP BOLT

NOTES:

REINFORCING BARS ARE IN METRIC UNITS.

NON-BREAKAWAY SIGN SUPPORTS FOR GROUND MOUNTED SIGNS

N.T.S.

CD-619-13

NEW JERSEY DEPARTMENT OF TRANSPORTATION

CONSTRUCTION DETAILS

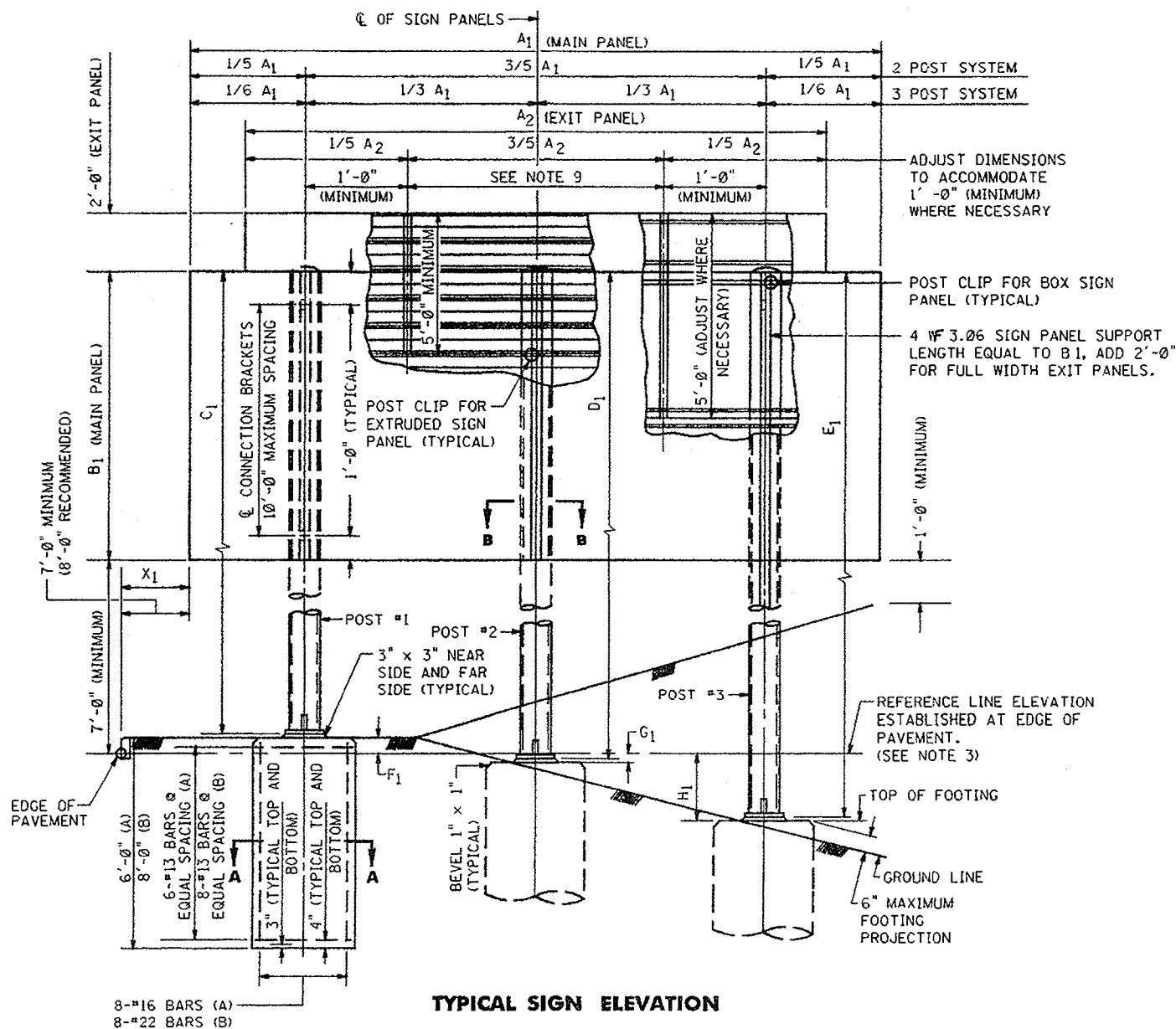

TYPICAL SIGN ELEVATION

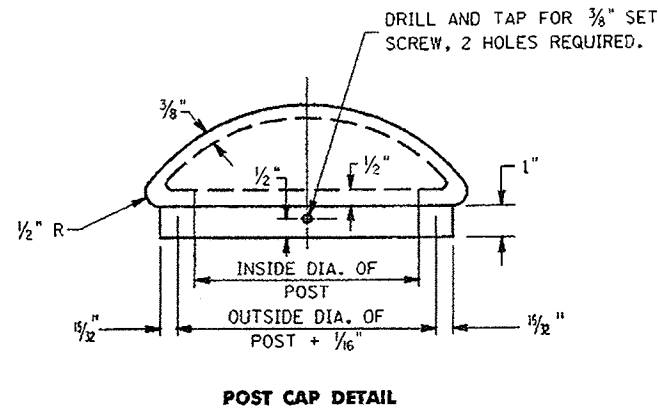

POST CAP DETAIL

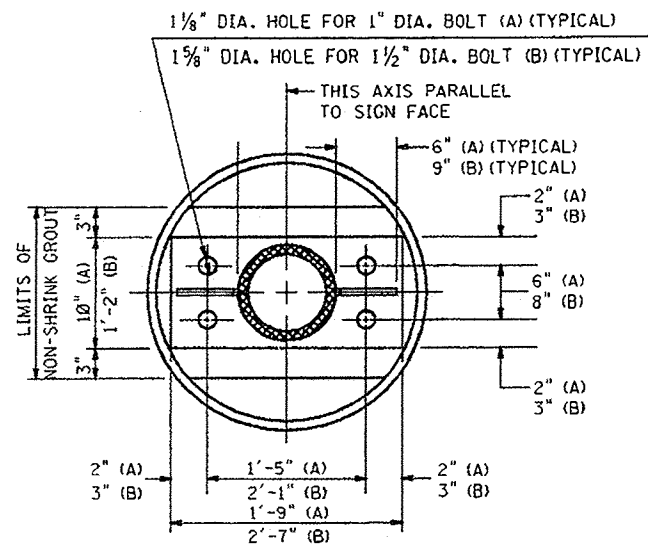

PLAN

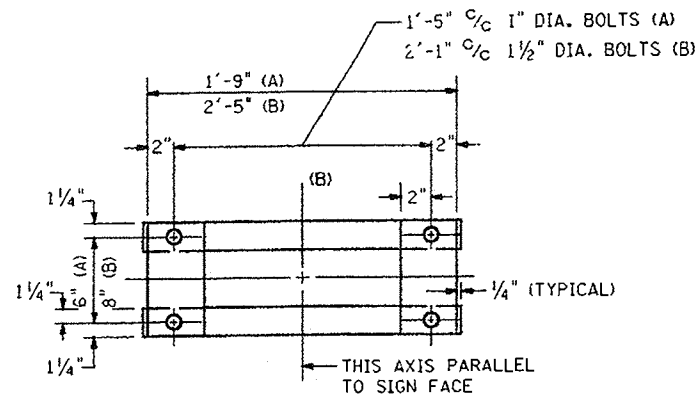

PLAN

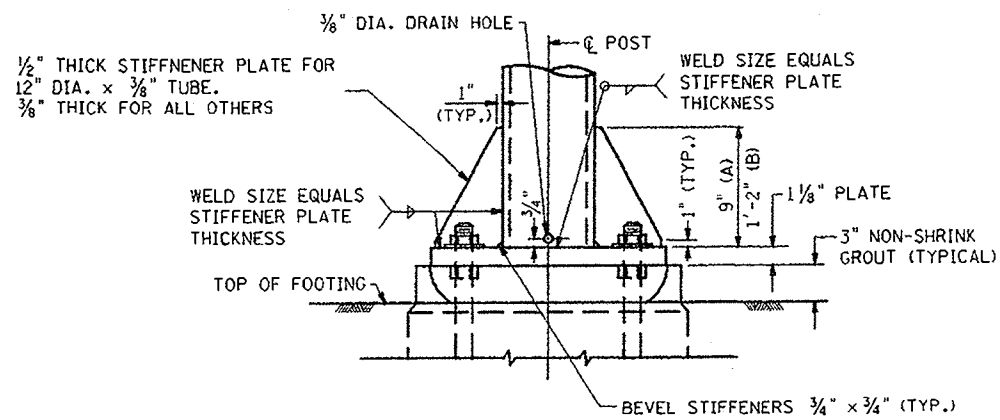

ELEVATION POST BASE DETAIL

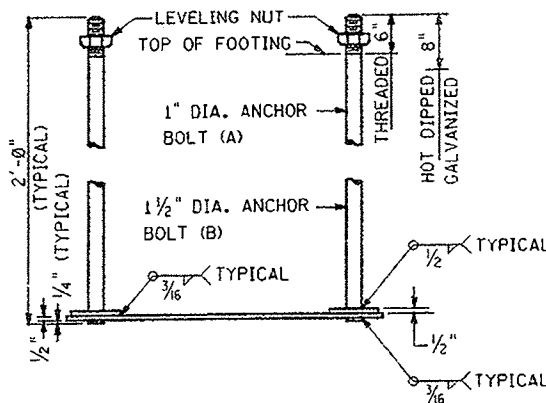

ELEVATION ANCHOR BOLT DETAIL

GENERAL NOTES:

1. USE CLASS "B" CONCRETE IN ALL FOOTINGS. ULTIMATE COMPRESSIVE STRENGTH $f'c = 3,000$ P.S.I..
2. ALL FOOTINGS SHALL BE PLACED AGAINST UNDISTURBED OR ADEQUATELY COMPACTED EARTH, EXCEPT FOR FOOTING TOPS WHICH SHALL BE FORMED TO A DEPTH OF 3 INCHES BELOW GROUND LINE.
3. TOPS OF FOOTINGS ABOVE REFERENCE LINE ARE INDICATED BY PLUS (+) VALUE; AND BELOW REFERENCE LINE BY MINUS (-) VALUE.
4. MATERIAL FOR STRUCTURAL SHAPES AND PLATES SHALL BE ALUMINUM ALLOY 6061-T6.
5. ANCHOR BOLT ASSEMBLY SHALL BE STRUCTURAL STEEL CONFORMING TO ASTM SPECIFICATION A36M OR EQUIVALENT WITH MINIMUM YIELD STRENGTH OF 36,000 P.S.I.. NUTS, WASHERS AND BOLTS SHALL BE HOT DIP GALVANIZED. THE TOP 6 INCHES OF ALL ANCHOR BOLTS SHALL BE THREADED.
6. WELDING OF ALUMINUM SHALL BE AS SPECIFIED IN THE SPECIFICATIONS.
7. UNUSUAL FOUNDATION CONDITIONS MAY REQUIRE REDESIGN OF FOOTING AND SUCH CONDITIONS SHALL BE BROUGHT TO THE ATTENTION OF THE ENGINEER.
8. DIMENSIONS FOR BASE TYPE A ARE DESIGNATED (A). DIMENSIONS FOR BASE TYPE B ARE DESIGNATED (B).

NON-BREAKAWAY SIGN SUPPORTS FOR GROUND MOUNTED SIGNS
N.T.S.

CD-619-14

NEW JERSEY DEPARTMENT OF TRANSPORTATION

CONSTRUCTION DETAILS

CD-619-14.1

pen table = /home/steve/...
 scale =
 date =
 file =

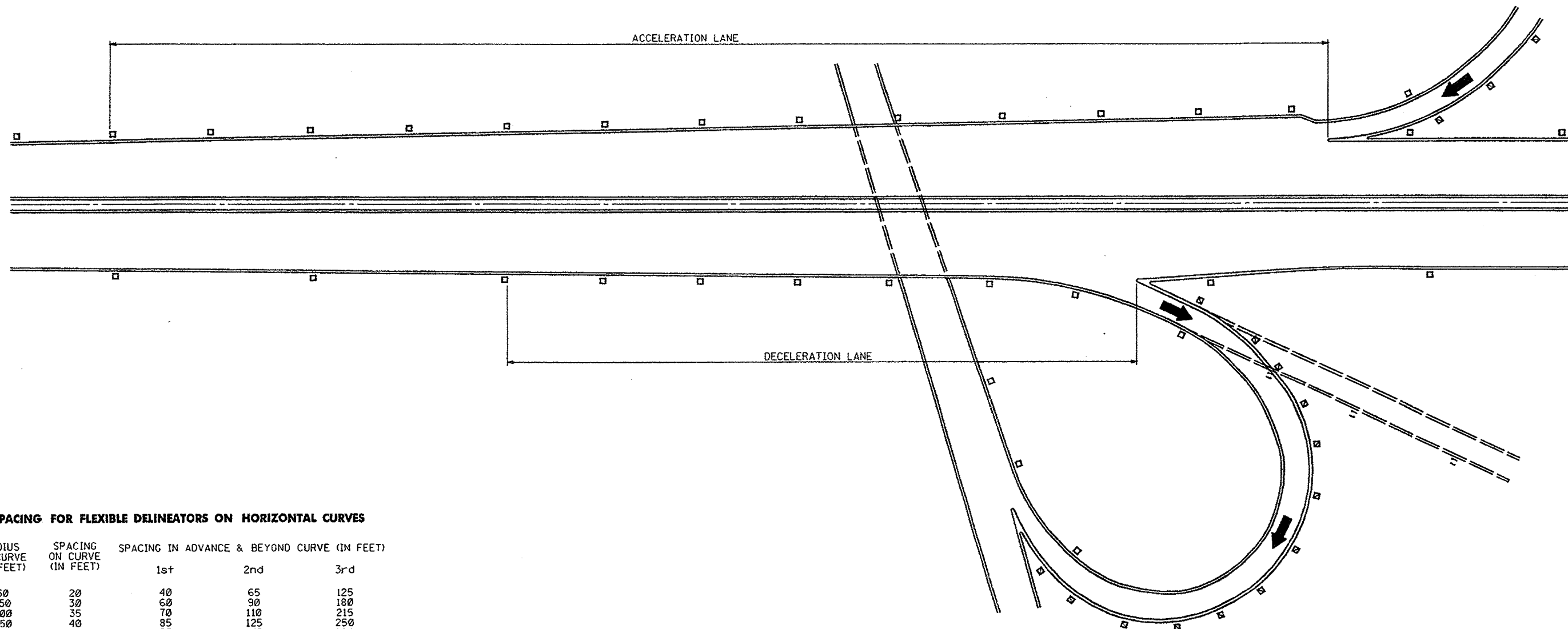

SPACING FOR FLEXIBLE DELINEATORS ON HORIZONTAL CURVES

RADIUS OF CURVE (IN FEET)	SPACING ON CURVE (IN FEET)	SPACING IN ADVANCE & BEYOND CURVE (IN FEET)		
		1st	2nd	3rd
50	20	40	65	125
150	30	60	90	180
200	35	70	110	215
250	40	85	125	250
300	50	95	145	290
400	55	110	170	300
500	65	125	190	300
600	70	140	210	300
700	75	150	230	300
800	80	165	245	300
900	85	175	260	300
1000	90	185	275	300

SPACING FOR SPECIFIC RADII NOT SHOWN MAY BE INTERPOLATED FROM TABLE. THE MINIMUM SPACING SHALL BE 20 FEET. THE SPACING ON CURVES SHALL NOT EXCEED 300 FEET. IN ADVANCE OF OR BEYOND A CURVE, AND PROCEEDING AWAY FROM THE END OF THE CURVE, THE SPACING OF THE FIRST DELINEATOR IS 2S, THE SECOND 3S, AND THE THIRD 6S BUT NOT TO EXCEED 300 FEET. S REFERS TO THE DELINEATOR SPACING FOR SPECIFIC RADII COMPUTED FROM THE FORMULA $S = 3\sqrt{R - 50}$

LEGEND

- WHITE FLEXIBLE DELINEATORS ON MAINLINE AT 200 FEET SPACING, ON RAMPS, ACCELERATION AND DECELERATION LANES 100 FEET MAXIMUM SPACING.
- YELLOW FLEXIBLE DELINEATORS ON RAMPS 100 FEET MAXIMUM SPACING.

INSTALLATION, DIMENSIONS, COLOR AND DETAILS TO FOLLOW STANDARDS IN THE CURRENT "MANUAL ON UNIFORM TRAFFIC CONTROL DEVICES FOR STREETS AND HIGHWAYS."

DELINEATORS
N.T.S.

CD-620-1
 NEW JERSEY DEPARTMENT OF TRANSPORTATION
CONSTRUCTION DETAILS

SWALE OR DITCH

DOUBLE WIDTH MATTING IN SWALE, USE 3'-6" OVERLAP WHERE TWO OR MORE STRIPS ARE REQUIRED, AND STAPLE ON 2'-0" CENTERS

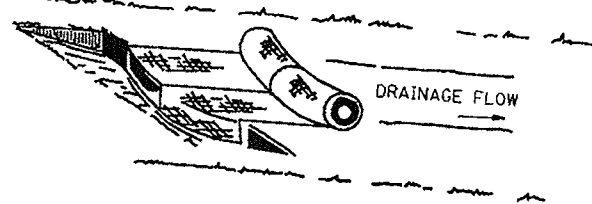

BURY TOP END OF MATTING IN A 6" TRENCH TAMP TRENCH FULL OF SOIL. SECURE WITH ROW OF STAPLES, 12" MAXIMUM SPACING 4" DOWN FROM TRENCH.

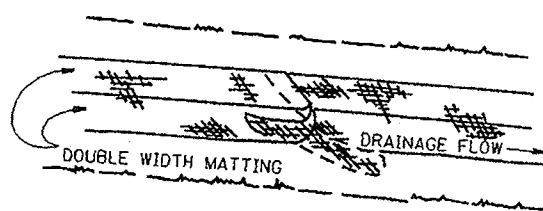

OVERLAP: BURY UPPER END OF LOWER STRIP AS PER ABOVE DETAIL. OVERLAP END OF TOP STRIP 6" AND STAPLE EITHER SIDE OF JOINT.

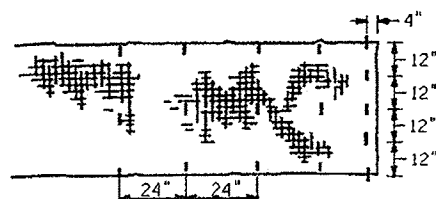

SECURE MATTING WITH STAPLES SPACED 24" APART ALONG THE SIDES AND DOWN THE CENTER. AT THE ENDS OF THE MATTING AND AT 50 FOOT INTERVALS STAPLES SHALL BE PLACED 12" APART ACROSS THE WIDTH.

TOPSOIL STABILIZATION

CD-809-1.1

INLET AND MOUND

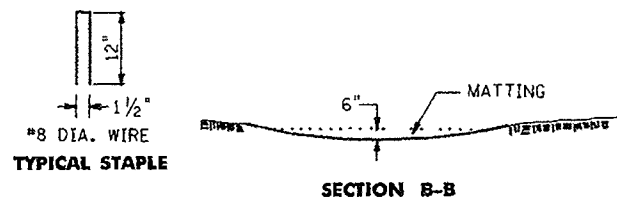
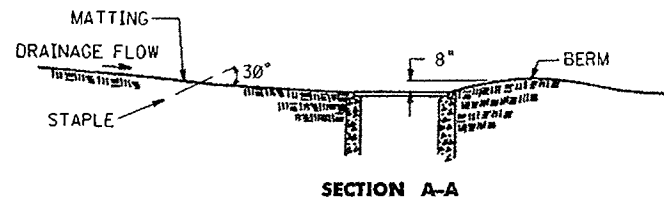
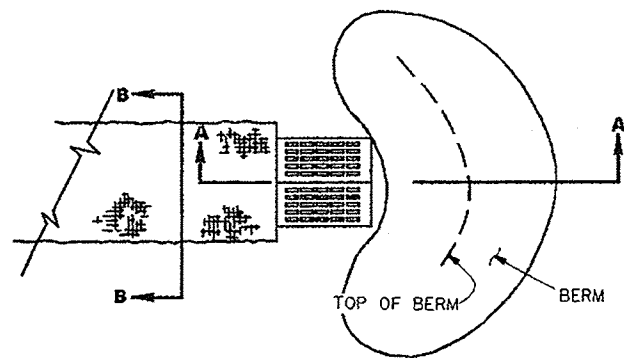

TOPSOIL STABILIZATION
N.T.S.

CD-809-1

NEW JERSEY DEPARTMENT OF TRANSPORTATION

CONSTRUCTION DETAILS

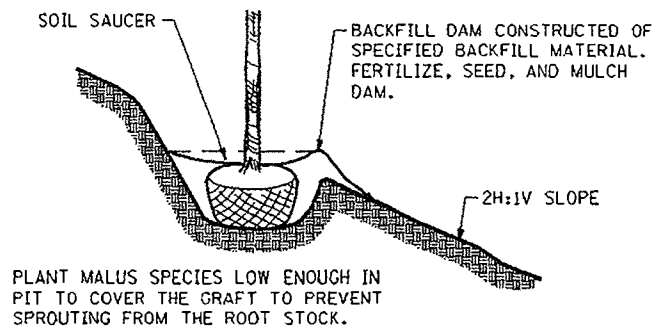

TREE PLANTING - 2H:1V SLOPE

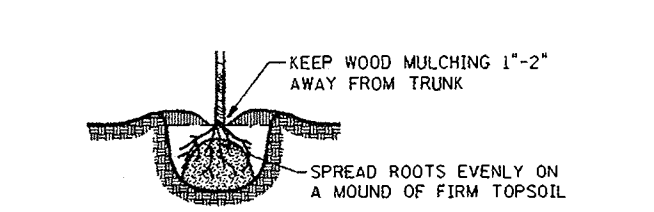
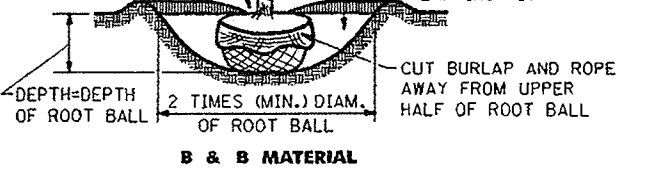
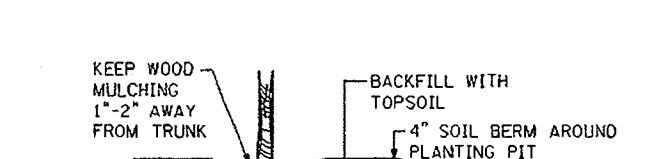

BARE ROOT MATERIAL

TREE & SHRUB PLANTING DETAIL

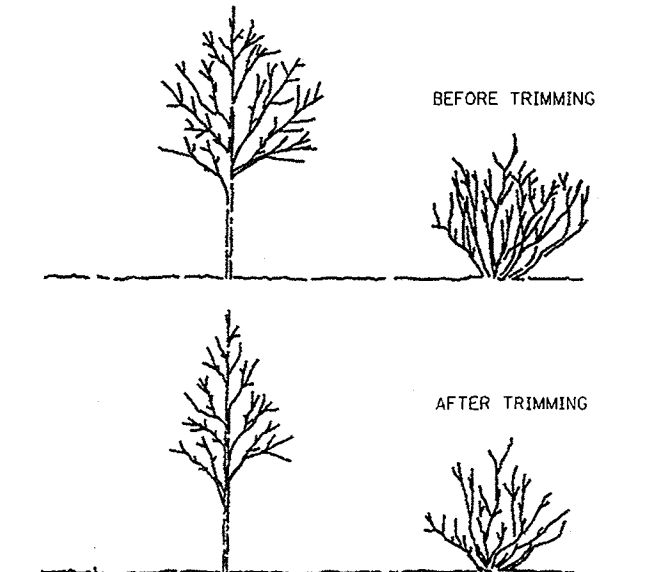

DAMAGED BRANCHES SHALL BE TRIMMED OFF BELOW THE POINT OF INJURY. THE CENTRAL TRUNK OR "LEADER" SHOULD BE LEFT INTACT AND THE SIDE BRANCHES SHOULD BE SHORTENED BY APPROXIMATELY ONE-THIRD TO ONE-HALF OF PREVIOUS SEASON'S GROWTH. BROKEN ROOTS SHALL BE CUT OFF ABOVE THE BREAK AND BRUISED ENDS CUT OFF CLEANLY.

WHEN PLANTING A YOUNG SHRUB, THIN TOP GROWTH BY ONE-THIRD TO BALANCE THE TOP WITH THE ROOTS. PRUNE JUST ABOVE A BUD AND RETAIN THE NATURAL SHAPE OF THE SHRUB.

PRUNING TREES WHEN PLANTING

POSTS - 2" x 2" x 8 FOOT LUMBER, STAINED DARK BROWN, OR 8 FOOT WHITE CEDAR POST 2" TO 3" DIAMETER AT THE THINNER (LOWER) END OF THE POST.

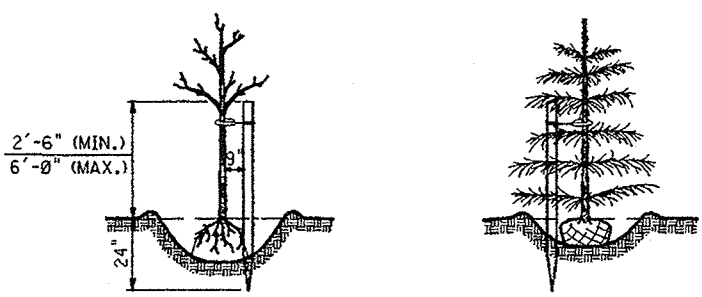

TREES REQUIRING ONE STAKE
 DECIDUOUS TREES (EXCEPT SALIX) 1" TO 1 1/2" CALIPER, INCLUSIVE. CONE TYPE (PYRAMIDAL) TREES 3 FEET TO 5 FEET HIGH, AND COLUMNAR EVERGREEN TREES 4 FEET TO 7 FEET HIGH, INCLUSIVE.

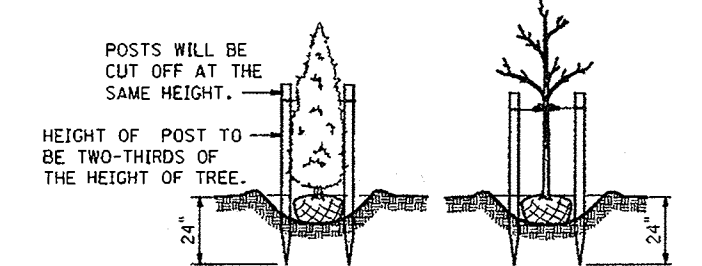

TREES REQUIRING TWO STAKES
 DECIDUOUS TREES OVER 1 1/2" TO 2 1/2" CALIPER, INCLUSIVE. ALL SALIX REGARDLESS OF HEIGHT, CALIPER, BARE ROOT OR BALLED AND BURLAPPED. CONE TYPE (PYRAMIDAL) TREES 5 FEET TO 7 FEET HIGH AND COLUMNAR EVERGREEN TREES 7 FEET TO 9 FEET HIGH, INCLUSIVE.

STAKING DETAILS

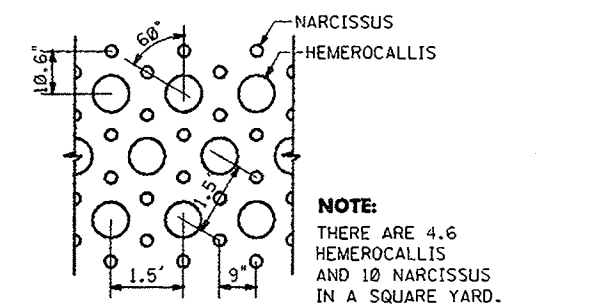

HEMEROCALLIS AND NARCISSUS BED PLANTING DETAIL

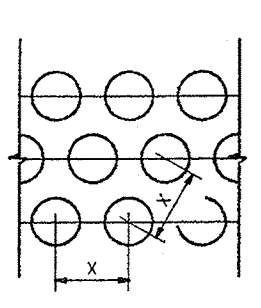

SHRUB BED PLANTING DETAIL

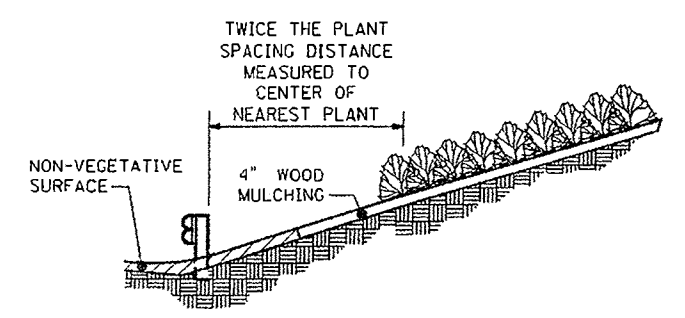

SHRUB PLANTING BEHIND GUIDE RAIL

DECIDUOUS TREES OVER 2 1/2" TO 4" CALIPER, CONE TYPE (PYRAMIDAL) TREES OVER 7 FEET HIGH.

STAKES - 2" x 4" LUMBER OR WHITE CEDAR, 2 1/2" DIAMETER AT THINNER (LOWER) END, NOTCHED 4" FROM THE TOP.

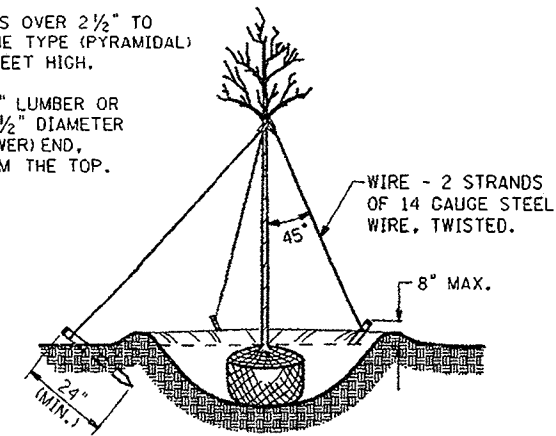

TREES REQUIRING THREE GUYS & STAKES

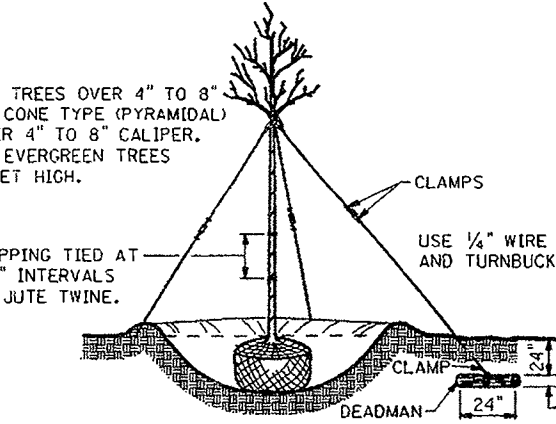

TREES REQUIRING THREE GUYS & DEADMEN

GUYING DETAILS

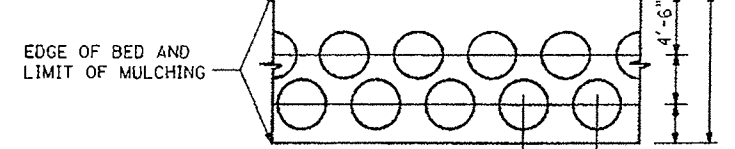
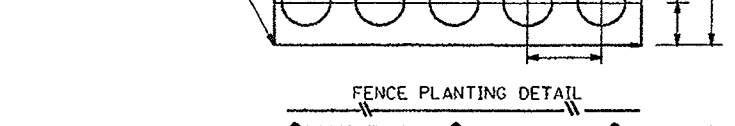
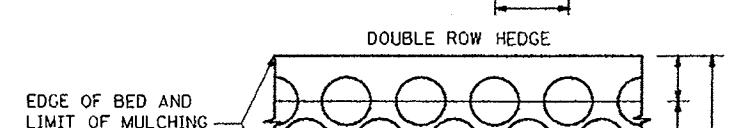
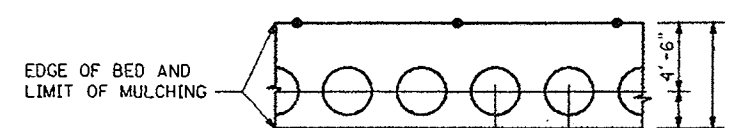
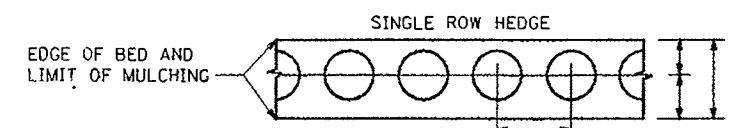

HEDGE PLANTING DETAILS

CD-813-1.1

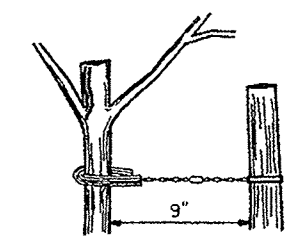

ANCHOR TREE TO POST(S) USING 14 GAUGE STEEL WIRE AND 1/2" CORDED RUBBER OR PLASTIC HOSE.

DETAIL OF POST AND GUY WIRE

GUY WIRES SHOULD BE PLACED AT LEAST HALF WAY UP THE TRUNK.

DETAIL OF GUY WIRES AROUND TRUNK

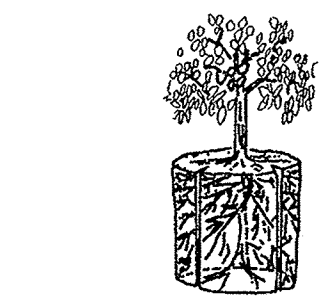
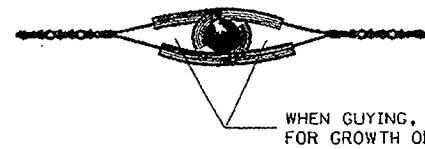

CONTAINERIZED PLANTS

FASTENING DETAIL

NOTE TO DESIGNER:
 THIS SHEET REQUIRES DESIGN SPECIFIC INFORMATION TO BE ADDED AND INCLUDED IN THE CONTRACT PLANS.
 REMOVE THIS NOTE AFTER DESIGN SPECIFIC INFORMATION IS ADDED.

PLANTING

N.T.S.

NEW JERSEY DEPARTMENT OF TRANSPORTATION

CONSTRUCTION DETAILS

CD-813-1

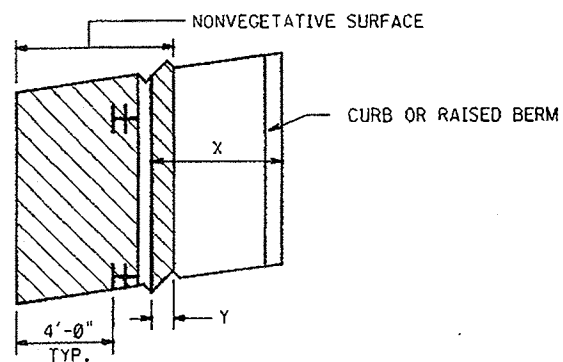

PLAN VIEW

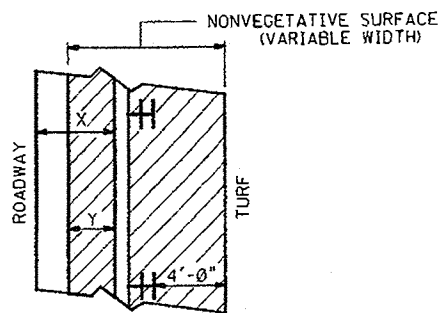

PLAN VIEW

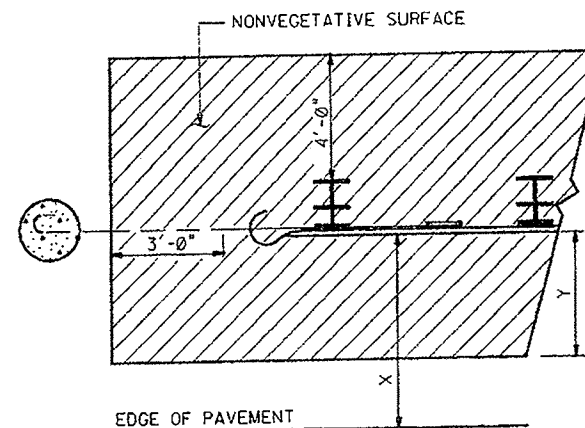

PLAN VIEW

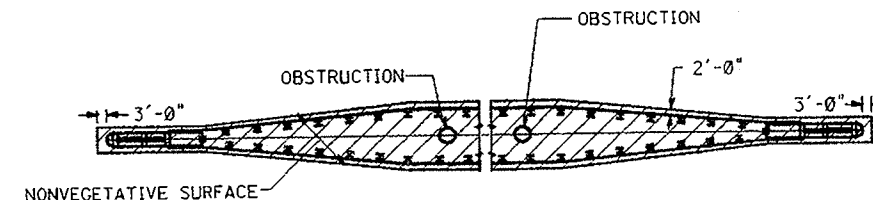

PLAN VIEW

NONVEGETATIVE SURFACE AT MEDIAN GUIDE RAIL

X	Y
GUIDE RAIL OFFSET FROM EDGE OF PAVEMENT	WIDTH OF NONVEGETATIVE SURFACE IN FRONT OF GUIDE RAIL
7'-0" OR GREATER	2'-0"
4'-0"	4'-0"
0'-0"	0'-0"

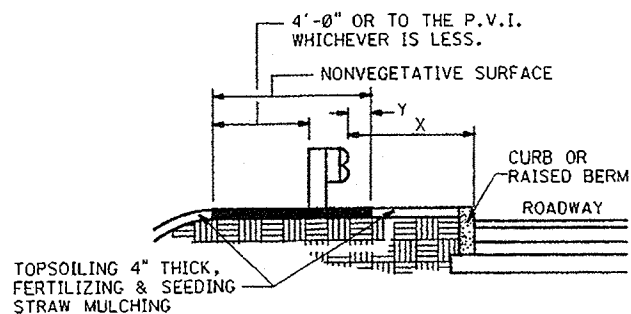

SECTION VIEW

NONVEGETATIVE SURFACES AROUND GUIDE RAIL BEHIND CURB OR RAISED BERM

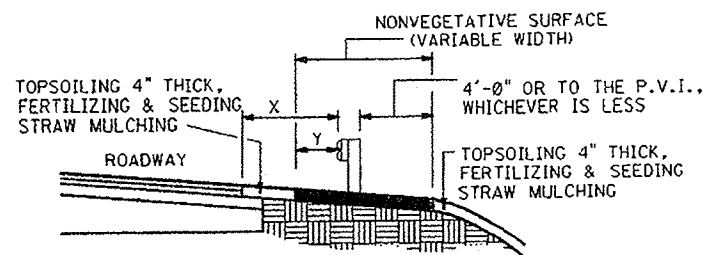

SECTION VIEW

NONVEGETATIVE SURFACE AT EDGE OF PAVEMENT ON UMBRELLA SECTION WHERE GUIDE RAIL IS USED

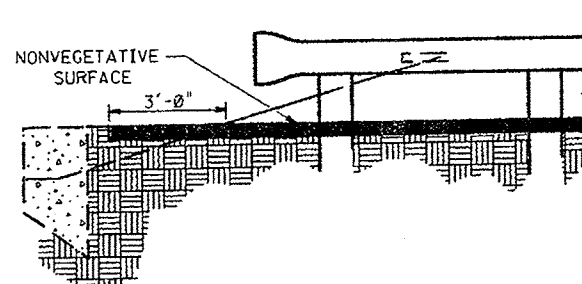

SECTION VIEW

NONVEGETATIVE SURFACES AROUND GUIDE RAIL ANCHORAGE TYPE I

GENERAL NOTES:

- IF THE END OF THE GUIDE RAIL IS BURIED IN THE SLOPE, THE LIMIT OF NONVEGETATIVE SURFACE RELATIVE TO THE BURIED GUIDE RAIL WILL BE DETERMINED BY THE RESIDENT ENGINEER.
- SEE TYPICAL SECTIONS FOR CROSS SLOPES IN ROADSIDE (BORDER OR SIDEWALK AREA).

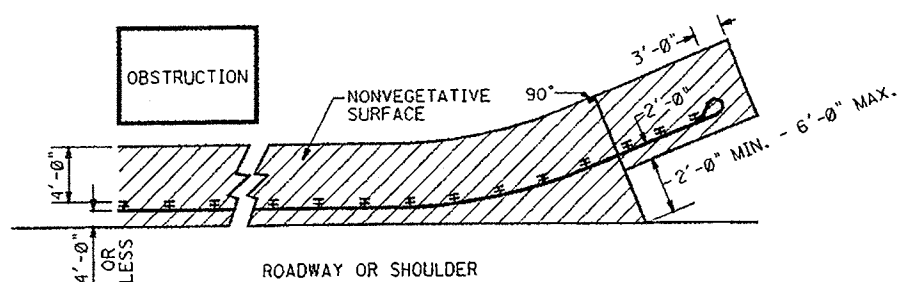

PLAN VIEW

NONVEGETATIVE SURFACE AROUND FLARED GUIDE RAIL WHERE GUIDE RAIL OFFSET FROM EDGE OF PAVEMENT IS 4'-0" OR LESS

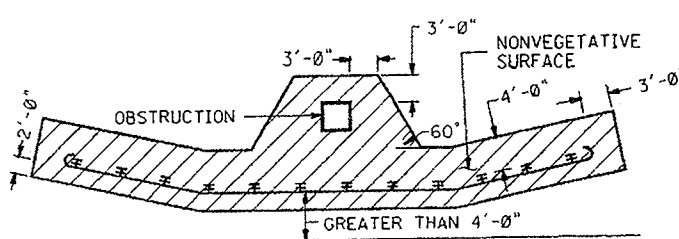

PLAN VIEW

NONVEGETATIVE SURFACE AROUND FLARED GUIDE RAIL WHERE GUIDE RAIL OFFSET FROM EDGE OF PAVEMENT IS GREATER THAN 4'-0"

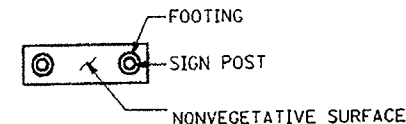

PLAN VIEW

THE NONVEGETATIVE SURFACE SHALL FORM A RECTANGULAR PAD WHOSE OUTSIDE LIMITS EXTEND A MINIMUM OF 3'-0" BEYOND THE POST FOOTING.

NONVEGETATIVE SURFACE AROUND OVERHEAD SIGN FOUNDATIONS AND UNDER LARGE GROUND MOUNTED SIGNS

NONVEGETATIVE SURFACE DETAILS

N.T.S.

NEW JERSEY DEPARTMENT OF TRANSPORTATION

CONSTRUCTION DETAILS

CD-814-1

92

129

CD-814-1.1





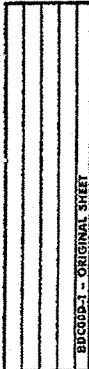











INDEX FOR STANDARD TRAFFIC CONTROL DETAILS

DESCRIPTION	TCD	DESCRIPTION	TCD
LEGEND AND GENERAL NOTES	TCD-1		
SIGHT DISTANCE	TCD-2		
TAPER LENGTH			
ESCAPE RAMP DETAIL			
PLACEMENT OF PRECAST CONCRETE CONSTRUCTION BARRIER			
CONSTRUCTION BARRIER, TYPE 4 JOINT CLASS & ALLOWABLE MOVEMENT			
2 LANES, UNDIVIDED, LANE & SHOULDER CLOSING	TCD-3		
2 LANES, UNDIVIDED, SHOULDER CLOSING	TCD-4		
2 LANES, UNDIVIDED, LANE & SHOULDER CLOSING W/FLAGGING			
2 LANES, UNDIVIDED, INTERSECTION			
4 LANES, UNDIVIDED, RIGHT LANE & SHOULDER CLOSING	TCD-5		
4 LANES, UNDIVIDED, SHOULDER CLOSING			
4 LANES, UNDIVIDED, LEFT LANE CLOSING	TCD-6		
4 LANES, UNDIVIDED, 2 LANES & SHOULDER ONE DIRECTION CLOSING	TCD-7		
4 LANES, UNDIVIDED, INTERSECTION	TCD-8		
4 & 6 LANES, DIVIDED, RIGHT LANE & SHOULDER CLOSING	TCD-9		
4 & 6 LANES, DIVIDED, SHOULDER CLOSING			
4 & 6 LANES, DIVIDED, LEFT LANE CLOSING			
6 LANES, DIVIDED, LEFT TWO LANES CLOSING	TCD-10		
6 LANES, DIVIDED, RIGHT TWO LANES CLOSING	TCD-11		
6 LANES, DIVIDED, CENTER LANE CLOSURE INITIATED BY LEFT LANE CLOSURE MAINTAIN 2 THROUGH LANES			
6 LANES, DIVIDED, CENTER LANE CLOSURE INITIATED BY RIGHT LANE CLOSURE MAINTAIN 2 THROUGH LANES	TCD-12		
DIVIDED, EXIT RAMP CONSTRUCTION, LEFT	TCD-13		
DIVIDED, EXIT RAMP CONSTRUCTION, RIGHT			
DIVIDED, EXIT RAMP CONSTRUCTION, LEFT WITH DECELERATION LANE	TCD-14		
DIVIDED, EXIT RAMP CONSTRUCTION, RIGHT WITH DECELERATION LANE			
DIVIDED, ENTRANCE RAMP CONSTRUCTION, LEFT	TCD-15		
DIVIDED, ENTRANCE RAMP CONSTRUCTION, RIGHT			
DIVIDED, ENTRANCE RAMP CONSTRUCTION, LEFT WITH ACCELERATION LANE	TCD-16		
DIVIDED, ENTRANCE RAMP CONSTRUCTION, RIGHT WITH ACCELERATION LANE			
MULTI-LANE ROAD MOVING OPERATION	TCD-17		
	TCD-18		
	TCD-19		
	TCD-20		
	TCD-21		
	TCD-22		



BDC005-1 - ORIGINAL SHEET

LEGEND

	BREAKAWAY BARRICADES
	BREAKAWAY BARRICADES WITH SIGN
	CONSTRUCTION SIGNS
	DRUMS
	CONE
	PRECAST CONCRETE CURB CONSTRUCTION BARRIER (TYPE SPECIFIED)
	DIRECTION OF TRAFFIC FLOW
	FLAGGER
	ILLUMINATED FLASHING ARROW MOUNTED ON TOWING VEHICLE SHOWING CAUTION MODE
	ILLUMINATED FLASHING ARROW MOUNTED ON TOWING VEHICLE SHOWING ARROW PATTERN (Left, Right, Both)
	TRAFFIC CONTROL TRUCK WITH MOUNTED CRASH CUSHION AND ARROW BOARD SHOWING CAUTION MODE
	TRAFFIC CONTROL TRUCK WITH MOUNTED CRASH CUSHION AND ARROW BOARD SHOWING ARROW PATTERN (Left, Right, Both)
	TEMPORARY CRASH CUSHION, INERTIAL BARRIER SYSTEM
	TEMPORARY CRASH CUSHION, (all other approved)
	BUFFER ZONE
	WORK AREA
	PAINT STRIPING TRUCK OR OTHER OPERATING VEHICLE

GENERAL NOTES:

- ADVANCE WARNING SIGNS, DISTANCES, AND TAPER LENGTHS MAY BE EXTENDED, AT DIRECTION OF THE ENGINEER, TO ADJUST FOR REDUCED VISIBILITY DUE TO HORIZONTAL AND VERTICAL CURVATURE OF THE ROADWAY.
- THE APPROXIMATE LOCATIONS OF THE ILLUMINATED FLASHING ARROW BOARDS ARE SHOWN ON THE TRAFFIC CONTROL PLANS. THESE LOCATIONS MAY BE MODIFIED TO ADJUST FOR VISIBILITY DUE TO HORIZONTAL OR VERTICAL CURVATURE OF THE ROADWAY OR TO POSITION AT A SAFER LOCATION. ILLUMINATED FLASHING ARROW BOARDS ARE TO BE USED FOR TEMPORARY LANE CLOSURES AND AT LOCATIONS SHOWN ON THE TRAFFIC CONTROL PLANS.
- PRIOR TO ANY ROAD CONSTRUCTION, TRAFFIC CONTROL SIGNS AND DEVICES SHALL BE IN PLACE.
- RAMPS AND/OR SIDE STREETS ENTERING THE ROADWAY AFTER THE FIRST ADVANCE WARNING SIGN SHALL BE PROVIDED WITH AT LEAST ONE W20-IF SIGN (ROAD WORK AHEAD) AS A MINIMUM.
- ALL EXISTING ROAD SIGNS, PAVEMENT MARKINGS AND/OR PLOWABLE PAVEMENT REFLECTORS WHICH CONFLICT WITH THE PROPOSED TRAFFIC CONTROL PLAN SHALL BE COVERED, REMOVED OR RELOCATED AS DIRECTED BY THE ENGINEER.
- CONFLICTING OR NON-OPERATING SIGNAL INDICATIONS ON EITHER THE EXISTING, TEMPORARY, OR PROPOSED TRAFFIC SIGNAL SYSTEMS SHALL BE BAGGED OR COVERED.
- MAINTENANCE AND PROTECTION OF TRAFFIC SHALL BE IN ACCORDANCE WITH THE MANUAL OF UNIFORM TRAFFIC CONTROL DEVICES - PART VI "STANDARDS AND GUIDES FOR TRAFFIC CONTROL FOR STREET AND HIGHWAY CONSTRUCTION, MAINTENANCE, UTILITY, AND INCIDENT MANAGEMENT OPERATIONS", UNLESS OTHERWISE NOTED IN THE PLANS AND SPECIFICATIONS, AND SHALL BE APPROVED BY THE ENGINEER.
- CONSTRUCTION SIGN W99-2 (GIVE US A BRAKE) SHALL BE LOCATED 200 FEET IN ADVANCE OF PROJECT LIMITS.
- A W1-6 (ARROW) SIGN MOUNTED ON A BREAKAWAY BARRICADE AND CENTERED ON THE CLOSED WIDTH SHALL BE LOCATED 100 FEET BEYOND EACH INTERSECTION OR MAIN ACCESS POINT WITHIN THE AREA OF A LANE OR SHOULDER CLOSURE.
- CONSTRUCTION SIGNS R11-4 (ROAD CLOSED TO THRU TRAFFIC) SHALL BE PLACED AT THE INTERSECTING STREETS WHICH ARE CLOSED TO TRAFFIC BECAUSE OF CONSTRUCTION.
- CONSTRUCTION SIGNS W8-9A (SYMBOL FOR UNEVEN PAVEMENT) AND W8-14A (GROOVED PAVEMENT) SHALL BE USED WHEN SUCH PAVEMENT CONDITIONS EXIST. THE PLACEMENT OF THESE SIGNS SHALL BE AS DIRECTED BY THE ENGINEER.
- MOVING WORK AREAS IN A PERMANENT LANE CLOSURE REQUIRE A TRAILER MOUNTED ILLUMINATED FLASHING TRUCK MOUNTED CRASH CUSHION THAT SHALL MOVE WITH THE WORK AREAS TO KEEP A 75 FOOT MINIMUM AND 175 FOOT MAXIMUM BUFFER IN ADVANCE OF EACH WORK AREA.
- THE CONTRACTOR SHALL SUBMIT A PLAN FOR THE SAFE ACCESS OF CONSTRUCTION VEHICLES THROUGHOUT THE WORK SITE WHERE SPACE CONSTRAINTS PREVENT THE USE OF LANE CLOSURES. THE PLAN SHALL BE SUBMITTED TO THE ENGINEER IN ACCORDANCE WITH SECTION 617 OF THE STANDARD SPECIFICATIONS.
- TRAFFIC SAFETY SERVICES SHALL BE USED IN ACCORDANCE WITH THE STANDARD SPECIFICATIONS FOR TRAFFIC CONTROL, SECTION 617.
- ALL EXCAVATED AREAS WITHIN OR ADJACENT TO THE ROADWAY SHALL BE BACKFILLED AND PLACED ON A MINIMUM 6H : 1V SLOPE PRIOR TO THE END OF EACH WORK DAY. OTHER EXCAVATED AREAS WITHIN THE CLEAR ZONE ARE TO BE EITHER BACKFILLED OR A PRECAST CONCRETE CURB CONSTRUCTION BARRIER SET TEMPORARILY IN PLACE TO SHIELD VEHICULAR AND PEDESTRIAN TRAFFIC.
- WHERE REQUIRED, THE CONTRACTOR SHALL MAKE PROVISIONS FOR MAINTAINING PEDESTRIAN CROSSING LOCATIONS AND TYPE AS DIRECTED BY THE ENGINEER.
- BITUMINOUS CONCRETE PLACED DURING THE VARIOUS CONSTRUCTION STAGES SHALL BE TRANSITIONED ON A MINIMUM 20H : 1V SLOPE TO MEET THE ADJACENT EXISTING GRADE AT THE LONGITUDINAL AND TRANSVERSE LIMITS OF THE STAGE CONSTRUCTION AREAS UNLESS OTHERWISE NOTED ON THE STAGE CONSTRUCTION PLANS.
- THE PLACEMENT AND OR RELOCATION OF PRECAST CONCRETE CURB, CONSTRUCTION BARRIER SHALL BE DONE DURING APPROVED OFF-PEAK HOURS WHEN TRAFFIC MAY BE REDUCED TO ONE LANE IN EACH DIRECTION.
- CONSTRUCTION ZONE SPEED LIMIT WILL BE DETERMINED BY THE REGIONAL TRAFFIC ENGINEER AT THE TIME OF OR DURING CONSTRUCTION, AS REQUESTED BY THE RESIDENT ENGINEER.
- THE SPEED LIMIT, R2-1 (BLACK ON WHITE) SIGN SHALL BE LOCATED THROUGH WORK AREAS AS DIRECTED BY THE REGIONAL TRAFFIC ENGINEER.
- THE REDUCED SPEED AHEAD SIGN, R2-5A(S) (BLACK ON WHITE) SHALL BE LOCATED IN ADVANCE OF SPEED LIMIT R2-1 SIGNS WHICH REDUCE THE NORMAL POSTED SPEED LIMIT THROUGH THE CONSTRUCTION ZONE.
- TRAFFIC FINES DOUBLED IN WORK AREA R(NJ)5-17(S), 4 FEET BY 2.5 FEET SIGN SHALL BE LOCATED 500 FEET AFTER THE FIRST ADVANCE WARNING SIGN, (W20 SERIES) AT EACH WORK AREA LOCATED WITHIN URBAN AREAS. THIS SIGN SHALL ALSO BE USED ON PROJECTS REQUIRING MOVING OPERATIONS IN WHICH CASE THE SIGN SHALL BE MOUNTED ON A SLOW MOVING CONSTRUCTION VEHICLE.
- THE FINAL BITUMINOUS CONCRETE SURFACE PAVEMENT SHALL NOT BE CONSTRUCTED UNTIL THE FINAL STAGE OF THE PROJECT. MANHOLES AND INLETS SHALL BE SET TO FINISHED GRADE AND TEMPORARY PAVEMENT RAMP ARE TO BE CONSTRUCTED AROUND THEM WITH A MINIMUM 20H : 1V SLOPE IN ALL DIRECTIONS USING HOT MIX ASPHALT PAVEMENT. THIS TEMPORARY MATERIAL WILL BE REMOVED IMMEDIATELY PRIOR TO PLACING THE SURFACE COURSE.
- TRAFFIC CONTROL DEVICES FOR LANE CLOSURES INCLUDING SIGNS, CONES, BARRICADES, ETC. SHALL BE PLACED AS SHOWN ON PLANS. SIGNS SHALL NOT BE PLACED WITHOUT ACTUAL LANE CLOSURES AND SHALL BE IMMEDIATELY REMOVED UPON REMOVAL OF THE CLOSURES.
- CONES MAY BE SUBSTITUTED FOR DRUMS AND INSTALLED UPON THE APPROVAL OF THE ENGINEER.

NOTE TO DESIGNER:

THIS SHEET REQUIRES DESIGN SPECIFIC INFORMATION TO BE ADDED AND INCLUDED IN THE CONTRACT PLANS.

REMOVE THIS NOTE AFTER DESIGN SPECIFIC INFORMATION IS ADDED.

TCD-1

NEW JERSEY DEPARTMENT OF TRANSPORTATION

TRAFFIC CONTROL DETAILS

94
129

APPROXIMATE LOCATION OF DRUMS DURING WORKING HOURS

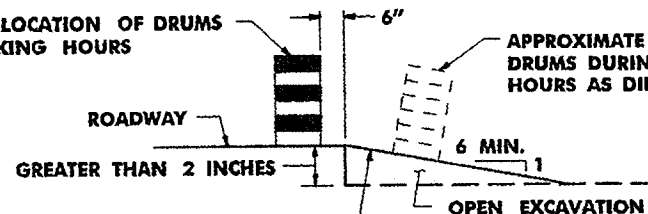

APPROXIMATE LOCATION OF DRUMS DURING NON-WORKING HOURS AS DIRECTED

FILLET OF MATERIAL DENSE GRADED AGGREGATE BASE COURSE OR OTHER MATERIAL AS APPROVED BY THE ENGINEER

NOTE:
ESCAPE RAMPS MUST BE CONSTRUCTED AND MAINTAINED DURING NON-WORKING HOURS WHERE A VERTICAL DROP GREATER THAN 2 INCHES EXISTS ADJACENT TO TRAVELED LANE.

ESCAPE RAMP DETAIL

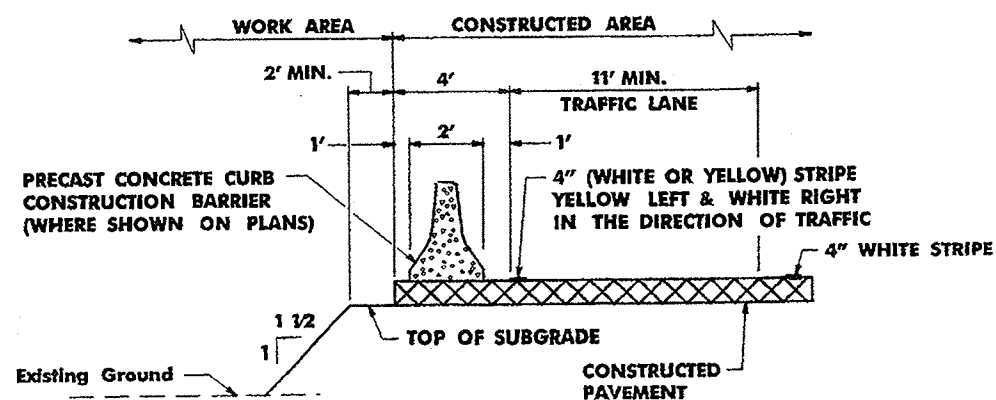

TYPICAL SECTION

PLACEMENT OF PRECAST CONCRETE CONSTRUCTION BARRIER

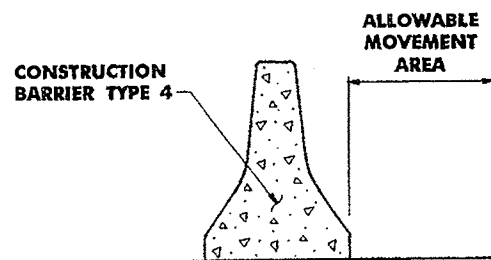

NOTES:

1. CHANGES TO THE PROPOSED JOINT CLASS AT ANY LOCATION MUST BE APPROVED BY THE ENGINEER.
2. NO WORK OR STORAGE OF MATERIALS WILL BE PERMITTED IN THE ALLOWABLE MOVEMENT AREA.

CONSTRUCTION BARRIER, TYPE 4 JOINT CLASS AND ALLOWABLE MOVEMENT

JOINT CLASS	ALLOWABLE MOVEMENT
A	OVER 16 TO 20 INCHES
B	11 TO 16 INCHES
C	LESS THAN 11 INCHES

STAGE	LOCATION	JOINT CLASS
	RTE. STA. TO STA.	

REGULATORY APPROACH SPEED OF TRAFFIC MILE/HOUR	RECOMMENDED SIGHT DISTANCE TO BEGINNING OF CHANNELIZING TAPERS		
	DESIRABLE		MINIMUM
	RURAL FEET	URBAN FEET	RURAL AND URBAN FEET
25	375	525	150
30	450	625	200
35	525	725	250
40	600	825	325
45	675	925	400
50	750	1025	475
55	875	1150	550
60	1000	1275	650
65	1050		725

NOTES:

1. AVOIDANCE MANEUVER IS FOR A SPEED, PATH, AND/OR DIRECTION CHANGE PRIOR TO THE BEGINNING OF CHANNELIZING TAPERS.
2. RECOMMENDED DISTANCES BETWEEN TWO SEPARATE LANE CLOSURES SHALL BE DOUBLE THE VALUES SHOWN ABOVE.
3. RURAL AND URBAN ROAD DESIGNATIONS SHALL BE AS DEFINED IN THE NJDOT STATE HIGHWAY STRAIGHT LINE DIAGRAMS.
4. DESIRABLE VALUES SHALL BE PROVIDED WHEREVER POSSIBLE. IF IT IS NOT FEASIBLE OR PRACTICAL TO PROVIDE DESIRABLE VALUES BECAUSE OF HORIZONTAL OR VERTICAL CURVATURE OR IF RELOCATION OF THE TAPER IS NOT POSSIBLE, THEN MINIMUM VALUES CAN BE APPLIED. WHEN MINIMUM VALUES ARE USED, SPECIAL ATTENTION SHOULD BE GIVEN TO THE USE OF SUITABLE TRAFFIC CONTROL DEVICES FOR PROVIDING ADVANCED WARNING OF THE CONDITIONS THAT ARE LIKELY TO BE ENCOUNTERED.
5. TAPERS SHALL BE LOCATED TO MAXIMIZE THE VISIBILITY OF THEIR TOTAL LENGTH.

REGULATORY APPROACH SPEED OF TRAFFIC MILE/HOUR	MINIMUM TAPER RATIO IN LENGTH PER FOOT OF WIDTH	RECOMMENDED TAPER LENGTH AND SPACING FOR CHANNELIZING TAPERS			MAXIMUM DEVICE (B) SPACING ALONG TAPERS IN FEET	RECOMMENDED SPACING ALONG TANGENTS
		MINIMUM TAPER LENGTH L - FOR LANE WIDTHS				
		10'	11'	12'		
25	10.5:1	105	115	125	25	50
30	15:1	150	165	180	30	60
35	20.5:1	205	225	245	35	70
40	27:1	270	300	325	40	80
45	45:1	450	495	540	45	90
50	50:1	500	550	600	50	100
55	55:1	550	605	660	55	110
60	60:1	600	660	720	60	120
65	65:1	650	715	780	65	130

NOTE:

THE MAXIMUM DEVICE SPACING ALONG CURVES SHALL BE AS DEFINED FOR TAPERS (B) IN THE ABOVE TABLE.

NOTE TO DESIGNER:

THIS SHEET REQUIRES DESIGN SPECIFIC INFORMATION TO BE ADDED AND INCLUDED IN THE CONTRACT PLANS.

REMOVE THIS NOTE AFTER DESIGN SPECIFIC INFORMATION IS ADDED.

N.T.S.

TCD-2

NEW JERSEY DEPARTMENT OF TRANSPORTATION

TRAFFIC CONTROL DETAILS

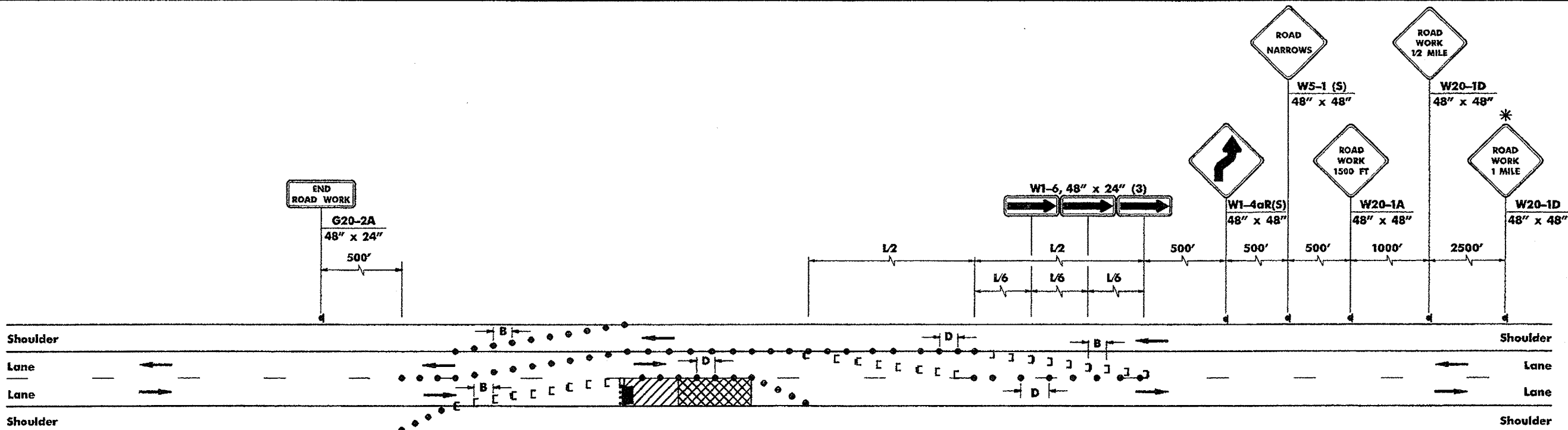

2 LANES, UNDIVIDED, LANE & SHOULDER CLOSING

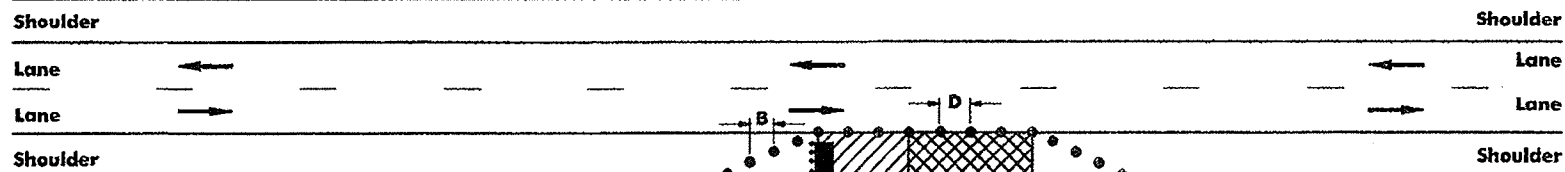
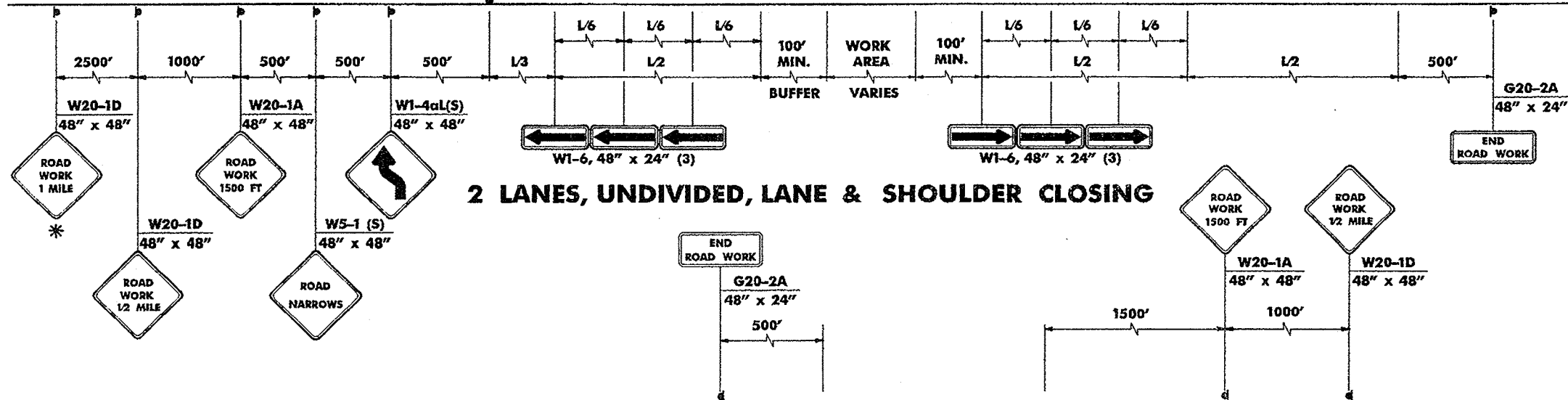

2 LANES, UNDIVIDED, SHOULDER CLOSING

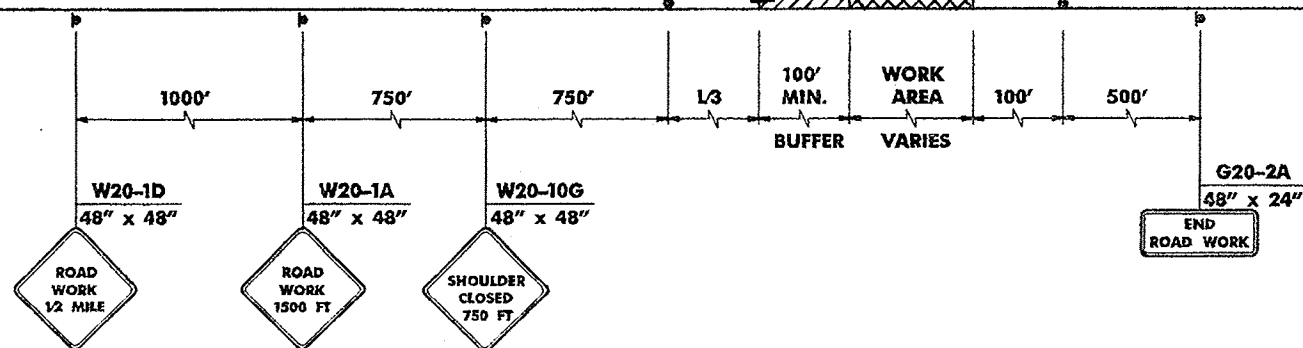

NOTE:
SEE RECOMMENDED TAPER LENGTH
AND SPACING TABLE ON SHEET
TCD-2 FOR VALUES OF L, B AND D.

N.T.S.

TCD-3

NEW JERSEY DEPARTMENT OF TRANSPORTATION

TRAFFIC CONTROL DETAILS

* — THIS SIGN SHALL BE INSTALLED
FOR ROADS WITH A SPEED LIMIT
OF 45 M.P.H. OR GREATER UNLESS
OTHERWISE DIRECTED BY THE
RESIDENT ENGINEER.

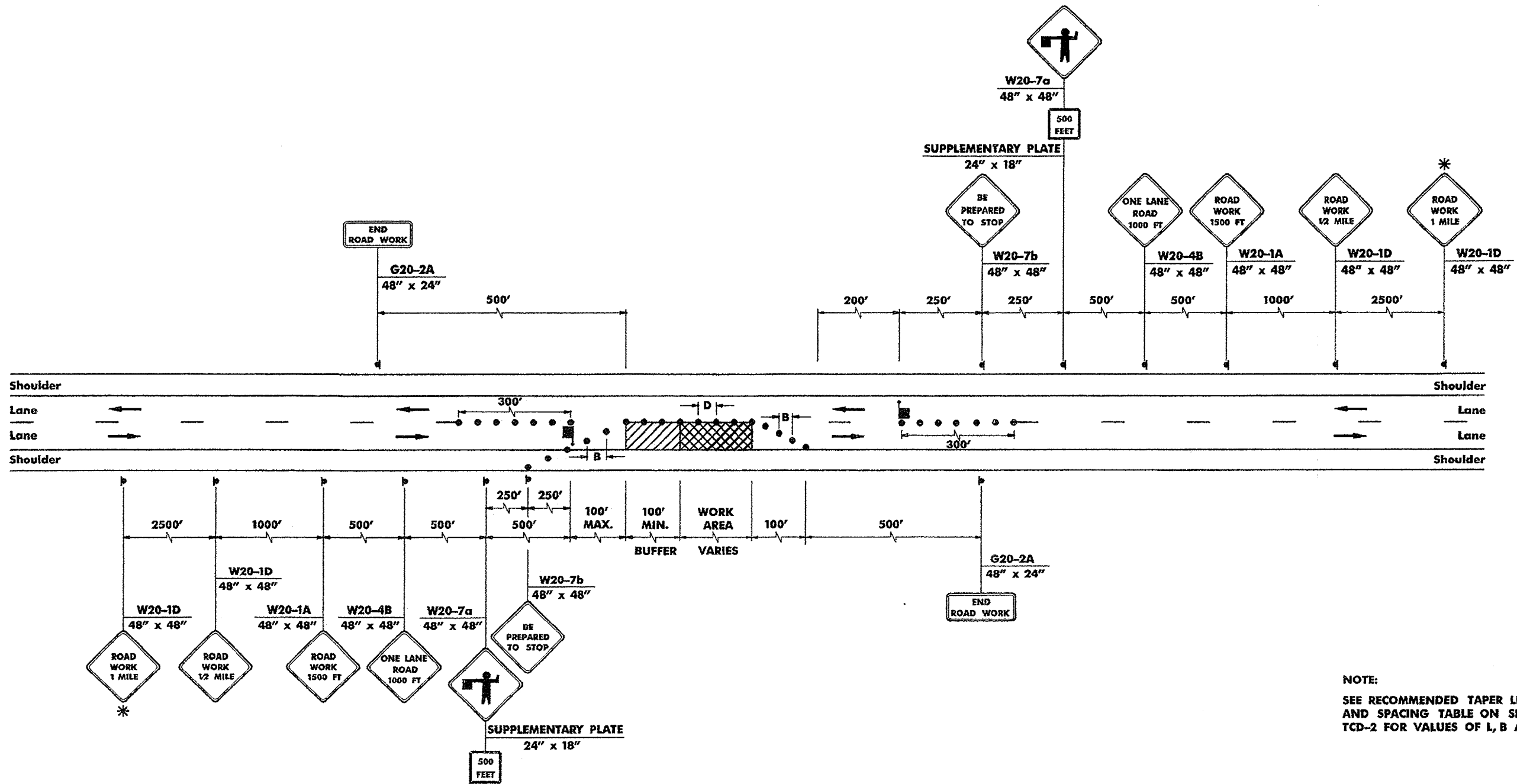

NOTE:
SEE RECOMMENDED TAPER LENGTH
AND SPACING TABLE ON SHEET
TCD-2 FOR VALUES OF L, B AND D.

2 LANES, UNDIVIDED, LANE & SHOULDER CLOSING W/FLAGGING

N.T.S.

TCD-4

NEW JERSEY DEPARTMENT OF TRANSPORTATION

TRAFFIC CONTROL DETAILS

* — THIS SIGN SHALL BE INSTALLED
FOR ROADS WITH A SPEED LIMIT
OF 45 M.P.H. OR GREATER UNLESS
OTHERWISE DIRECTED BY THE
RESIDENT ENGINEER.

2 LANES, UNDIVIDED, INTERSECTION

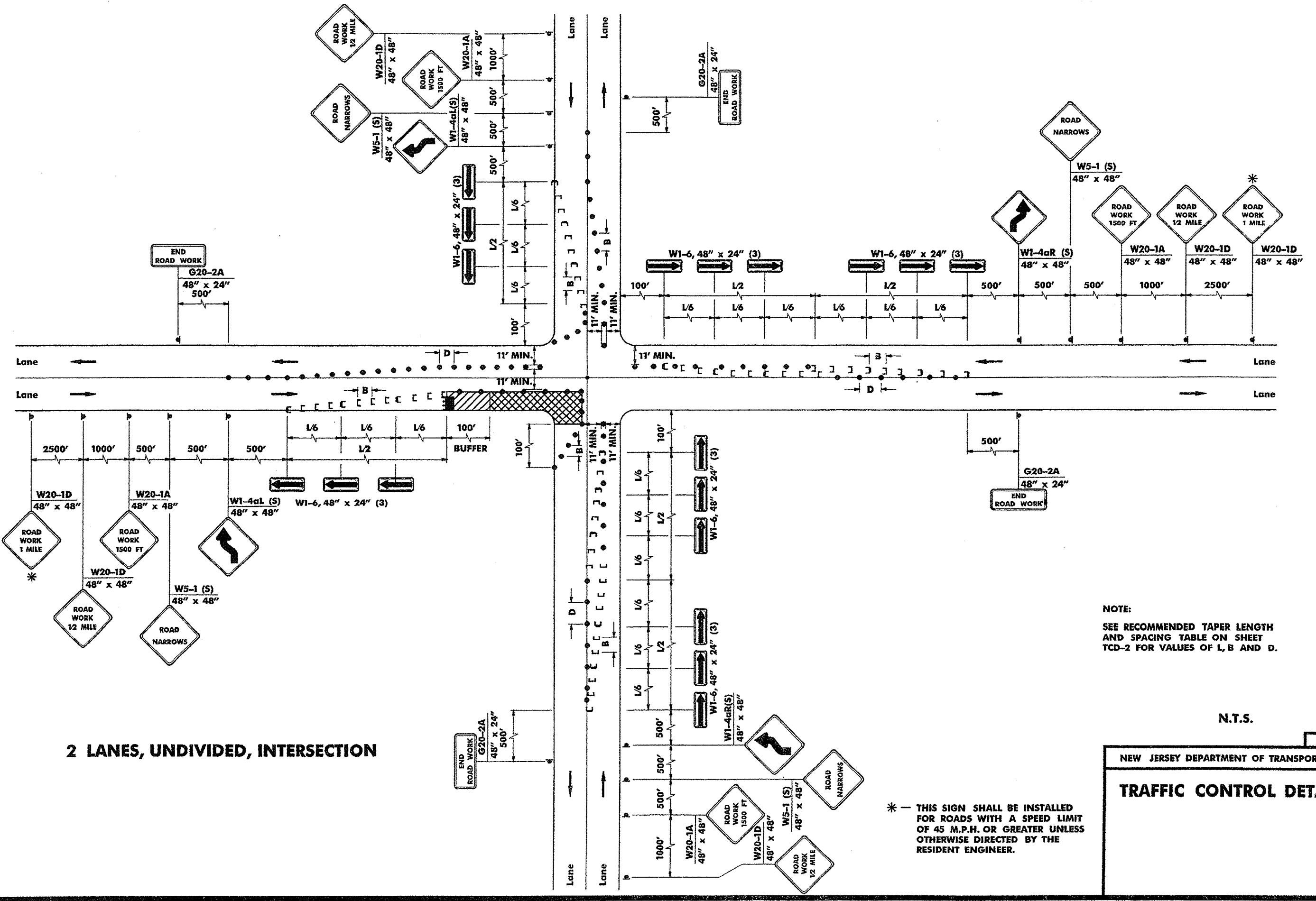

NOTE:
SEE RECOMMENDED TAPER LENGTH
AND SPACING TABLE ON SHEET
TCD-2 FOR VALUES OF L, B AND D.

N.T.S.

* - THIS SIGN SHALL BE INSTALLED
FOR ROADS WITH A SPEED LIMIT
OF 45 M.P.H. OR GREATER UNLESS
OTHERWISE DIRECTED BY THE
RESIDENT ENGINEER.

TCD-5
NEW JERSEY DEPARTMENT OF TRANSPORTATION

TRAFFIC CONTROL DETAILS

RECORD - ORIGINAL SHEET

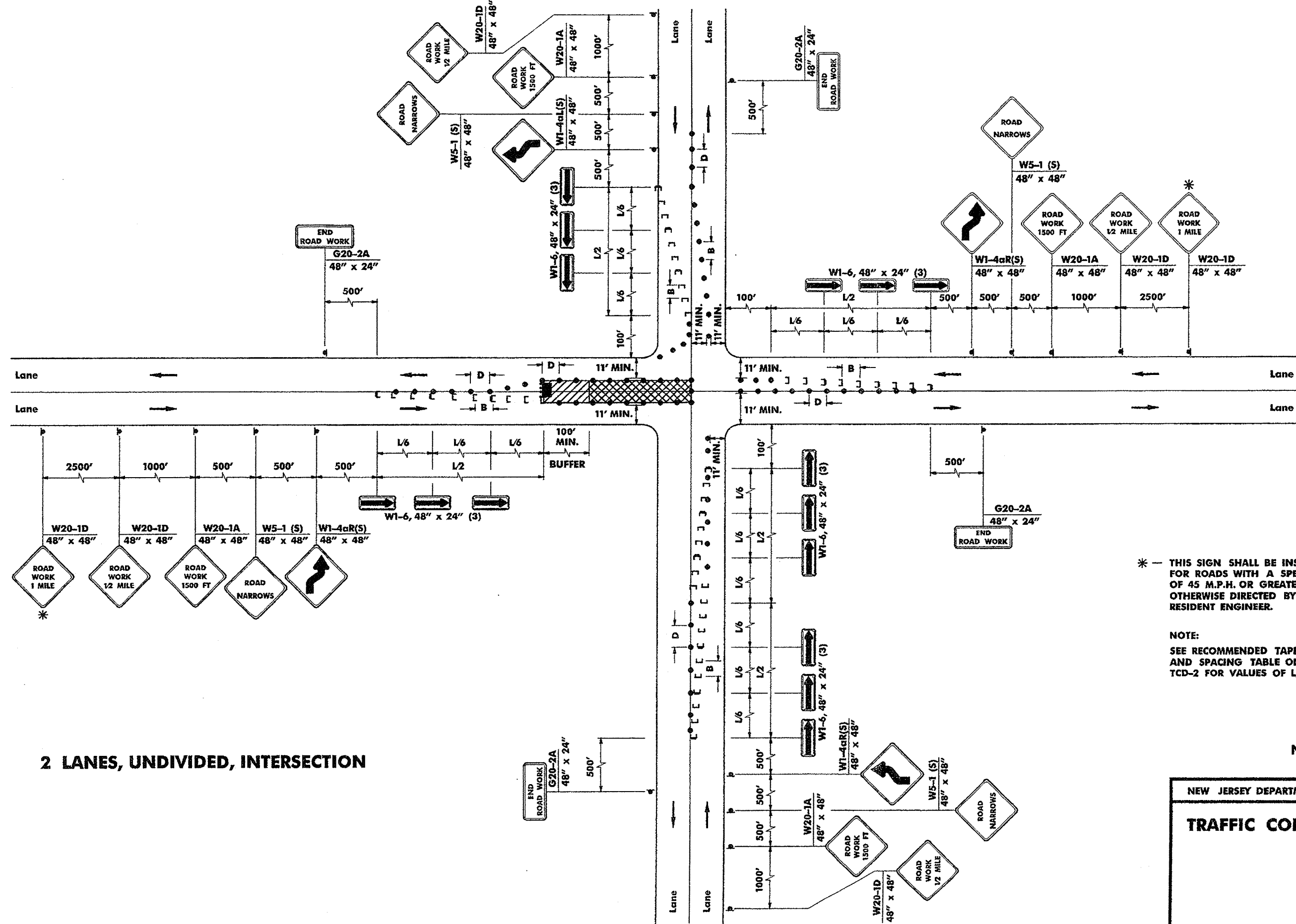

2 LANES, UNDIVIDED, INTERSECTION

* - THIS SIGN SHALL BE INSTALLED FOR ROADS WITH A SPEED LIMIT OF 45 M.P.H. OR GREATER UNLESS OTHERWISE DIRECTED BY THE RESIDENT ENGINEER.

NOTE:
SEE RECOMMENDED TAPER LENGTH AND SPACING TABLE ON SHEET TCD-2 FOR VALUES OF L, B AND D.

N.T.S.

NEW JERSEY DEPARTMENT OF TRANSPORTATION
TRAFFIC CONTROL DETAILS

TCD-6

Den Yable = /...
 80018 = ...
 00000 = ...
 00000 = ...

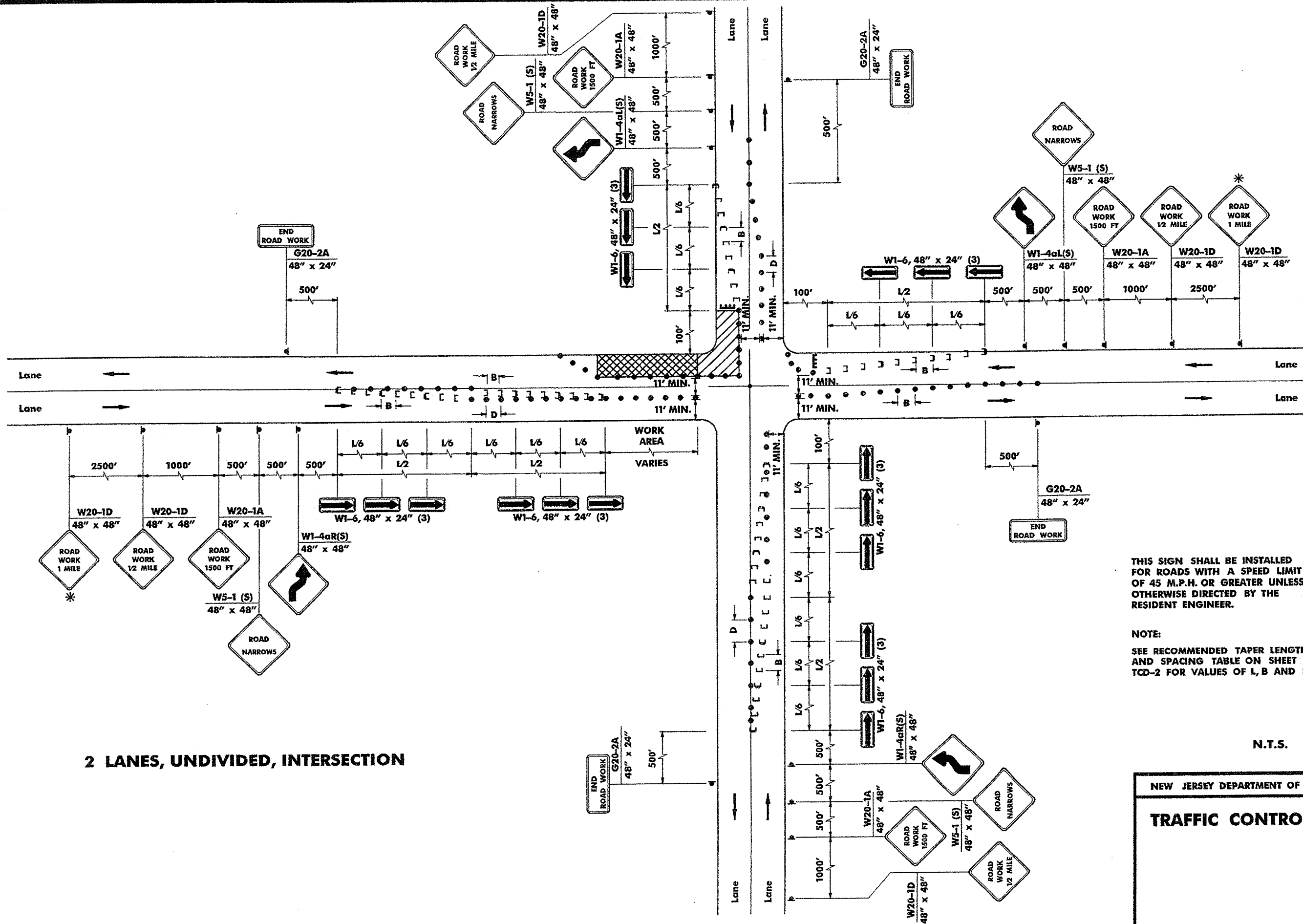

2 LANES, UNDIVIDED, INTERSECTION

THIS SIGN SHALL BE INSTALLED FOR ROADS WITH A SPEED LIMIT OF 45 M.P.H. OR GREATER UNLESS OTHERWISE DIRECTED BY THE RESIDENT ENGINEER.

NOTE:
SEE RECOMMENDED TAPER LENGTH AND SPACING TABLE ON SHEET TCD-2 FOR VALUES OF L, B AND D.

N.T.S.

TCD-7

NEW JERSEY DEPARTMENT OF TRANSPORTATION

TRAFFIC CONTROL DETAILS

100
129

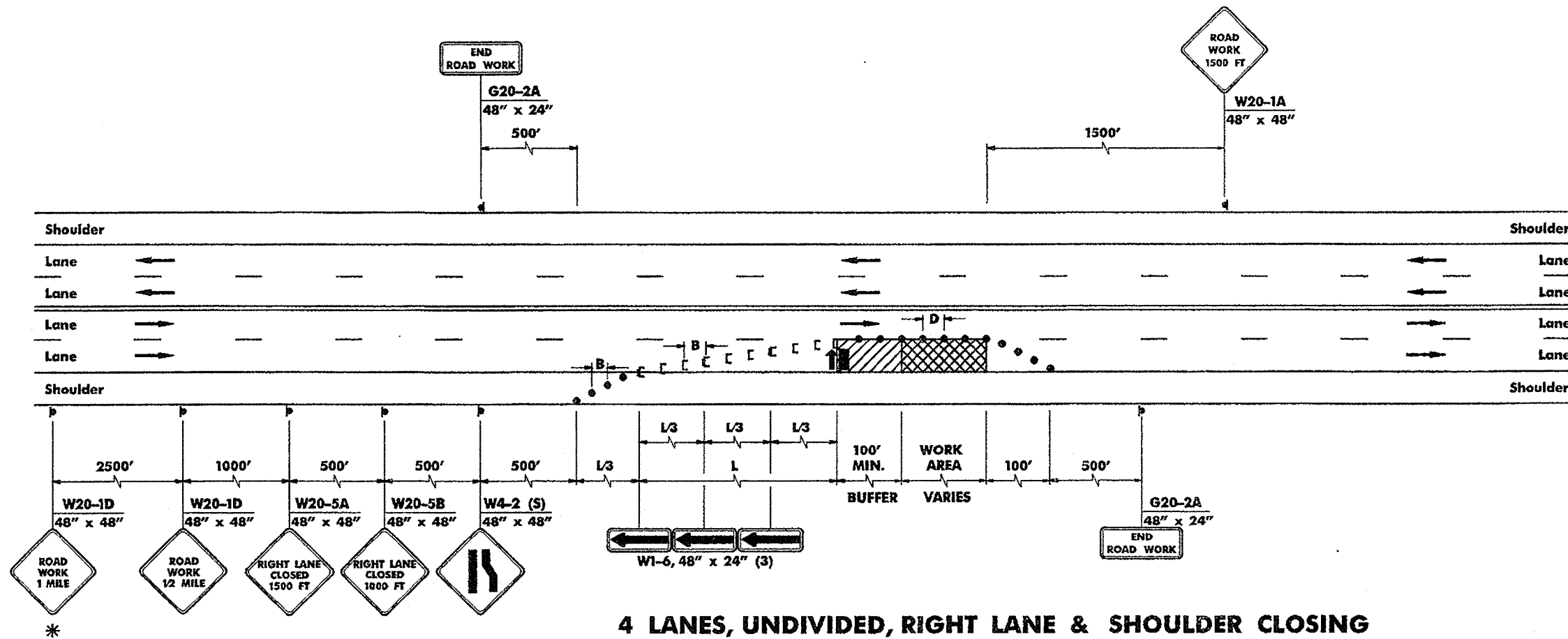

ORIGINAL SHEET

*

*

4 LANES, UNDIVIDED, RIGHT LANE & SHOULDER CLOSING

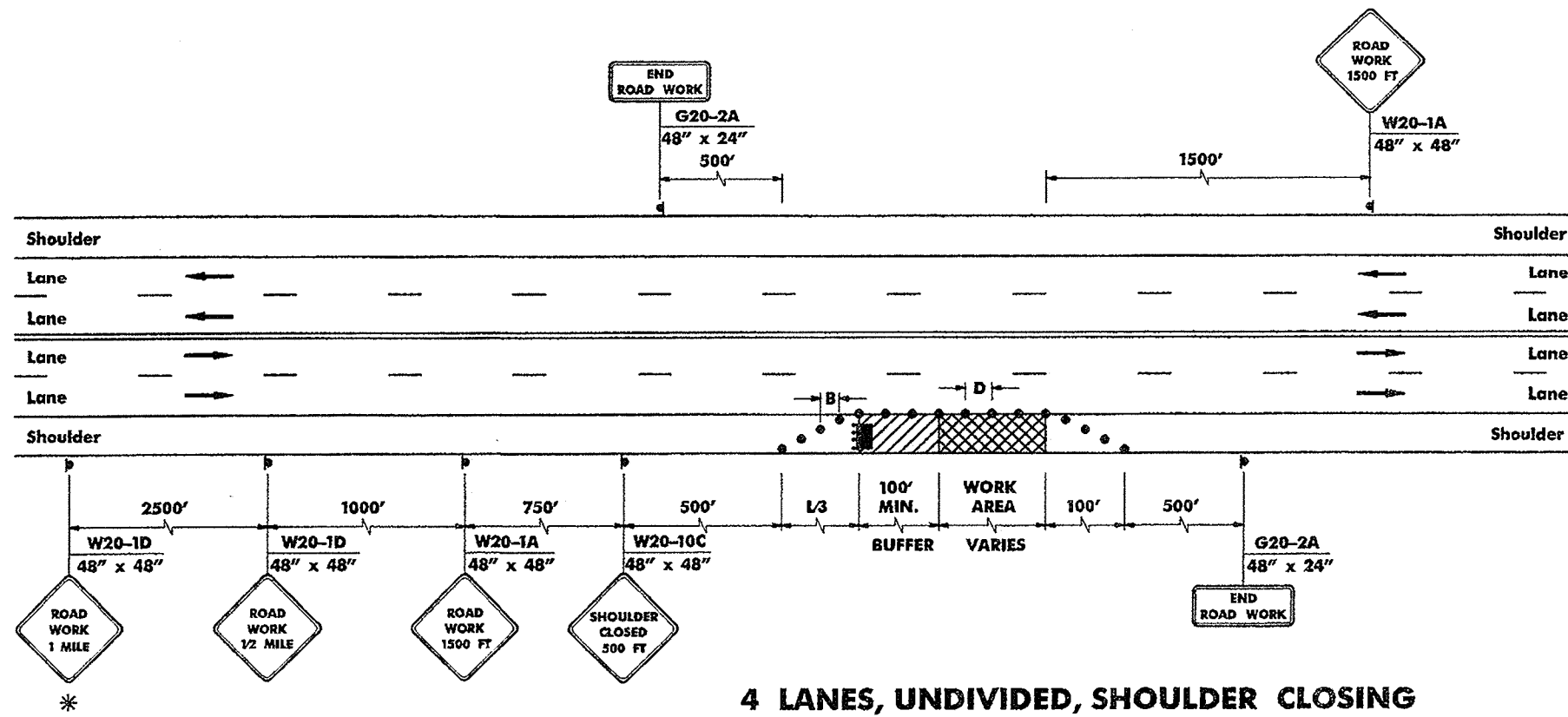

* — THIS SIGN SHALL BE INSTALLED FOR ROADS WITH A SPEED LIMIT OF 45 M.P.H. OR GREATER UNLESS OTHERWISE DIRECTED BY THE RESIDENT ENGINEER.

NOTE:
SEE RECOMMENDED TAPER LENGTH AND SPACING TABLE ON SHEET TCD-2 FOR VALUES OF L, B AND D.

N.T.S.

TCD-8

NEW JERSEY DEPARTMENT OF TRANSPORTATION

TRAFFIC CONTROL DETAILS

101
129

pen table = Anubusosivity2_plotlabshalf-scale.tbl

scale =

queue =

date =

file =

D =

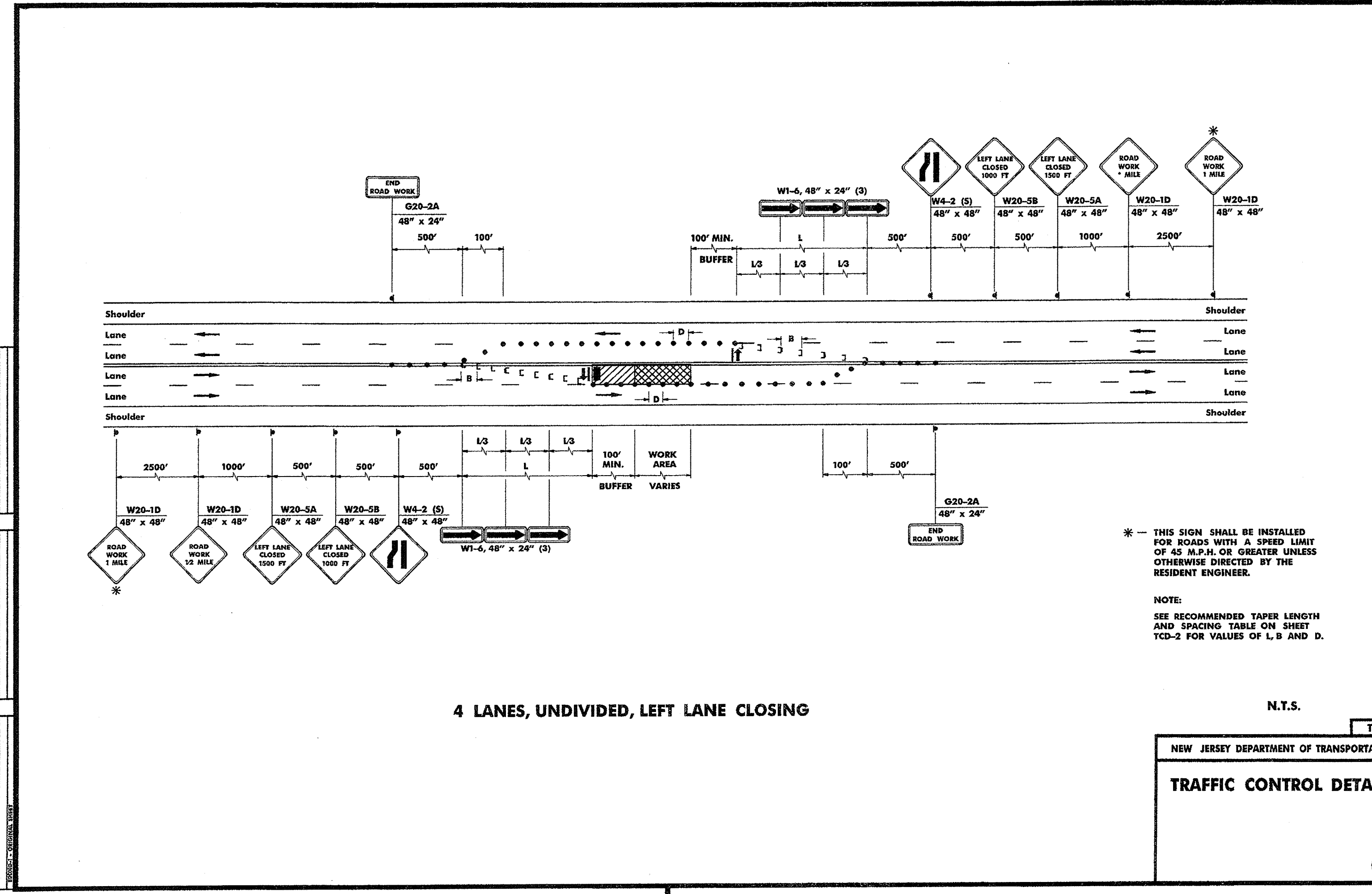

* — THIS SIGN SHALL BE INSTALLED FOR ROADS WITH A SPEED LIMIT OF 45 M.P.H. OR GREATER UNLESS OTHERWISE DIRECTED BY THE RESIDENT ENGINEER.

NOTE:
SEE RECOMMENDED TAPER LENGTH AND SPACING TABLE ON SHEET TCD-2 FOR VALUES OF L, B AND D.

4 LANES, UNDIVIDED, LEFT LANE CLOSING

N.T.S.

TCD-9

NEW JERSEY DEPARTMENT OF TRANSPORTATION

TRAFFIC CONTROL DETAILS

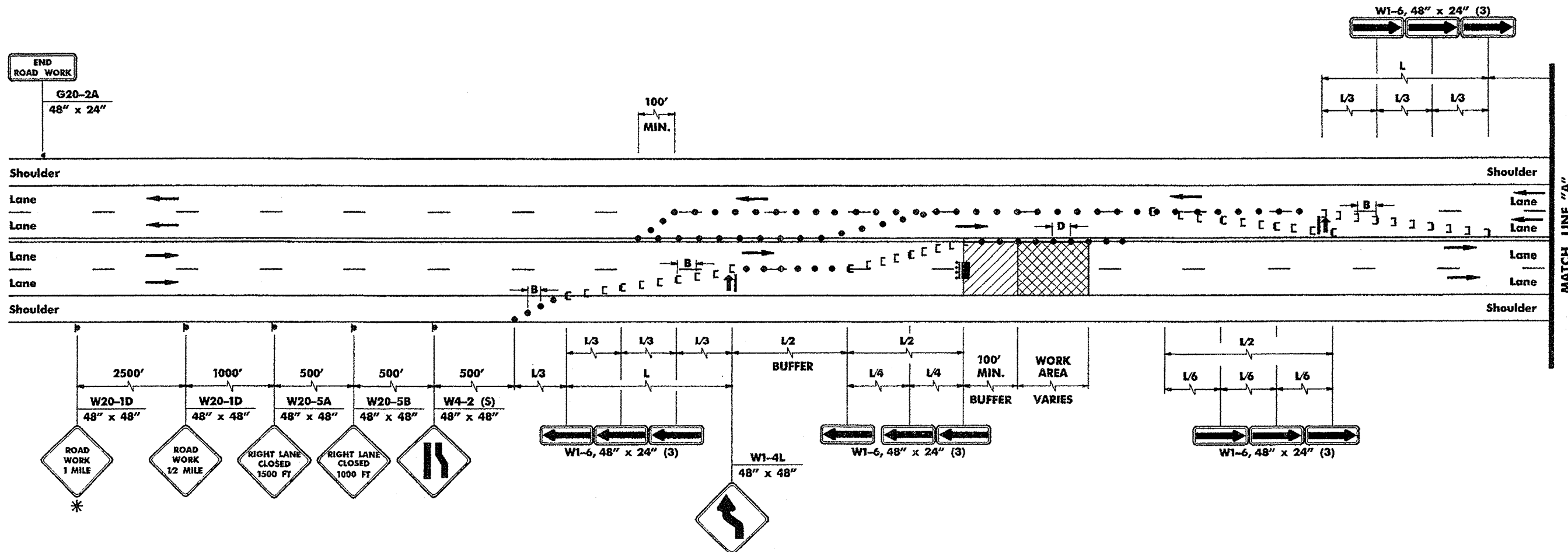

4 LANES, UNDIVIDED, 2 LANES & SHOULDER ONE DIRECTION CLOSING

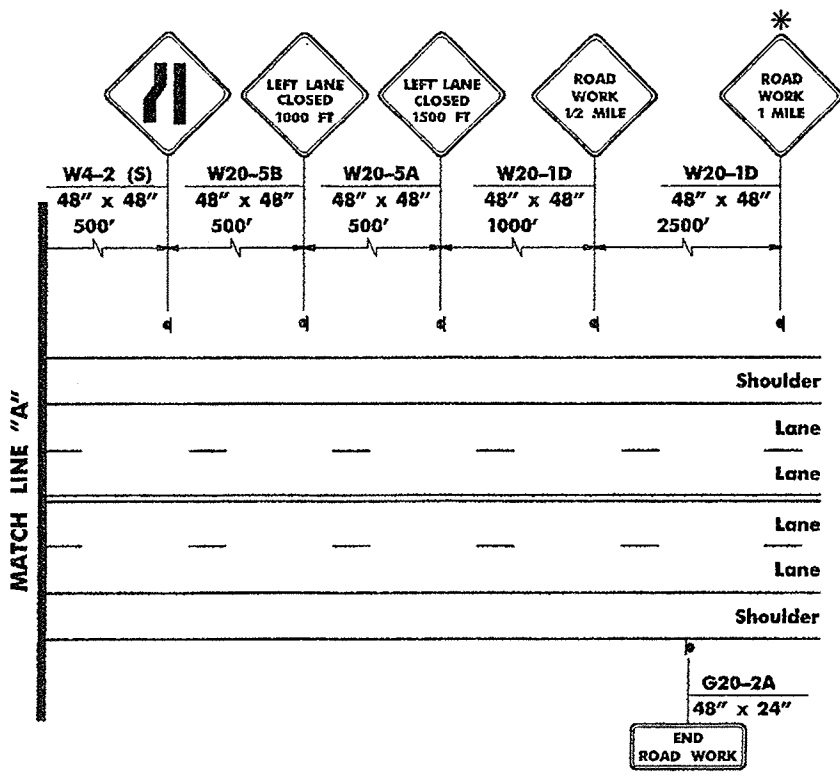

* — THIS SIGN SHALL BE INSTALLED FOR ROADS WITH A SPEED LIMIT OF 45 M.P.H. OR GREATER UNLESS OTHERWISE DIRECTED BY THE RESIDENT ENGINEER.

NOTE:
SEE RECOMMENDED TAPER LENGTH AND SPACING TABLE ON SHEET TCD-2 FOR VALUES OF L, B AND D.

N.T.S.

TCD-10

NEW JERSEY DEPARTMENT OF TRANSPORTATION

TRAFFIC CONTROL DETAILS

RECORD - ORIGINAL SHEET

per table = /roadwork.indd_g_plottablehalf-scale.tbl
 scale =
 queue =
 date =
 file =

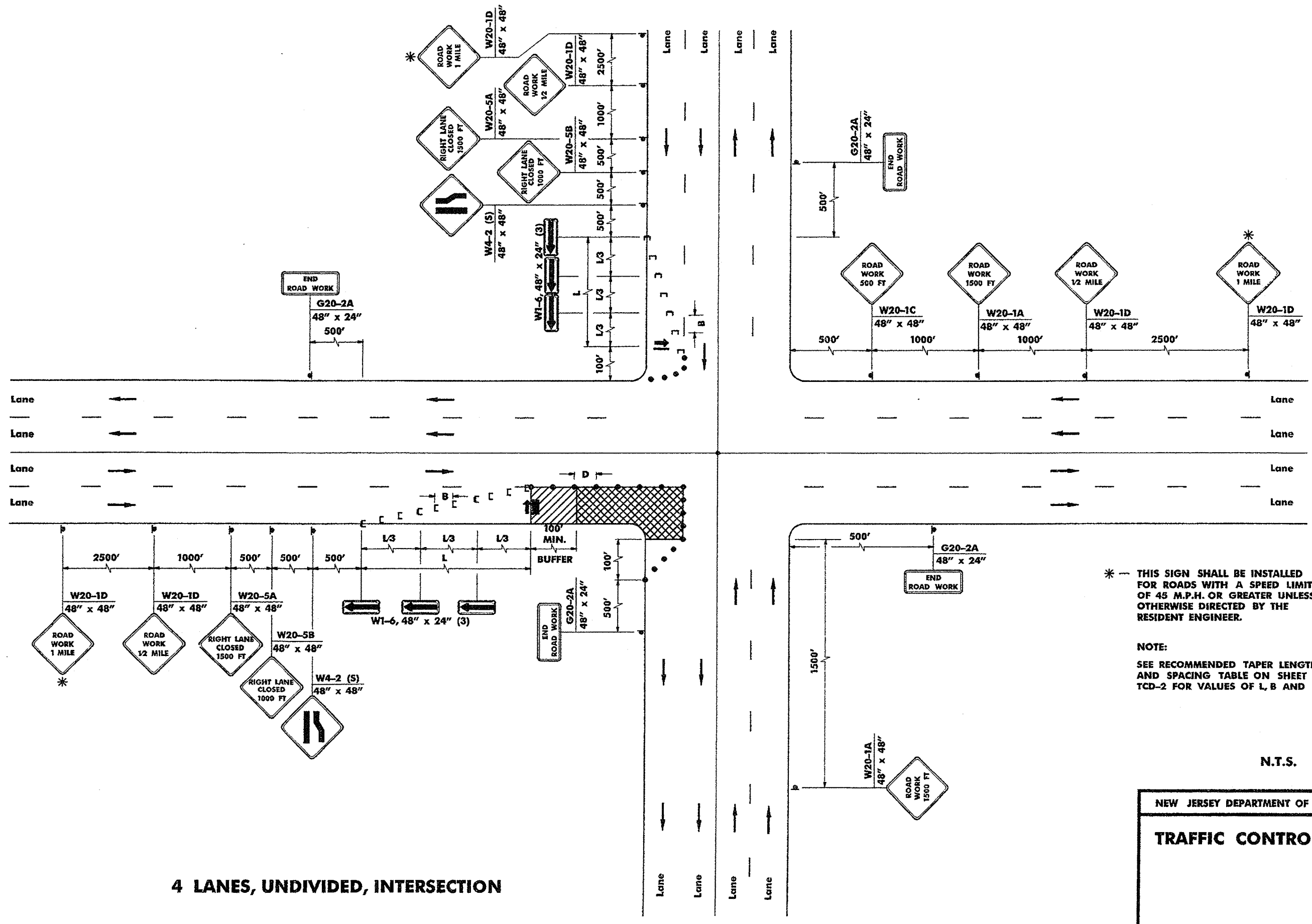

4 LANES, UNDIVIDED, INTERSECTION

* — THIS SIGN SHALL BE INSTALLED FOR ROADS WITH A SPEED LIMIT OF 45 M.P.H. OR GREATER UNLESS OTHERWISE DIRECTED BY THE RESIDENT ENGINEER.

NOTE:
 SEE RECOMMENDED TAPER LENGTH AND SPACING TABLE ON SHEET TCD-2 FOR VALUES OF L, B AND D.

N.T.S.

TCD-11
 NEW JERSEY DEPARTMENT OF TRANSPORTATION
TRAFFIC CONTROL DETAILS

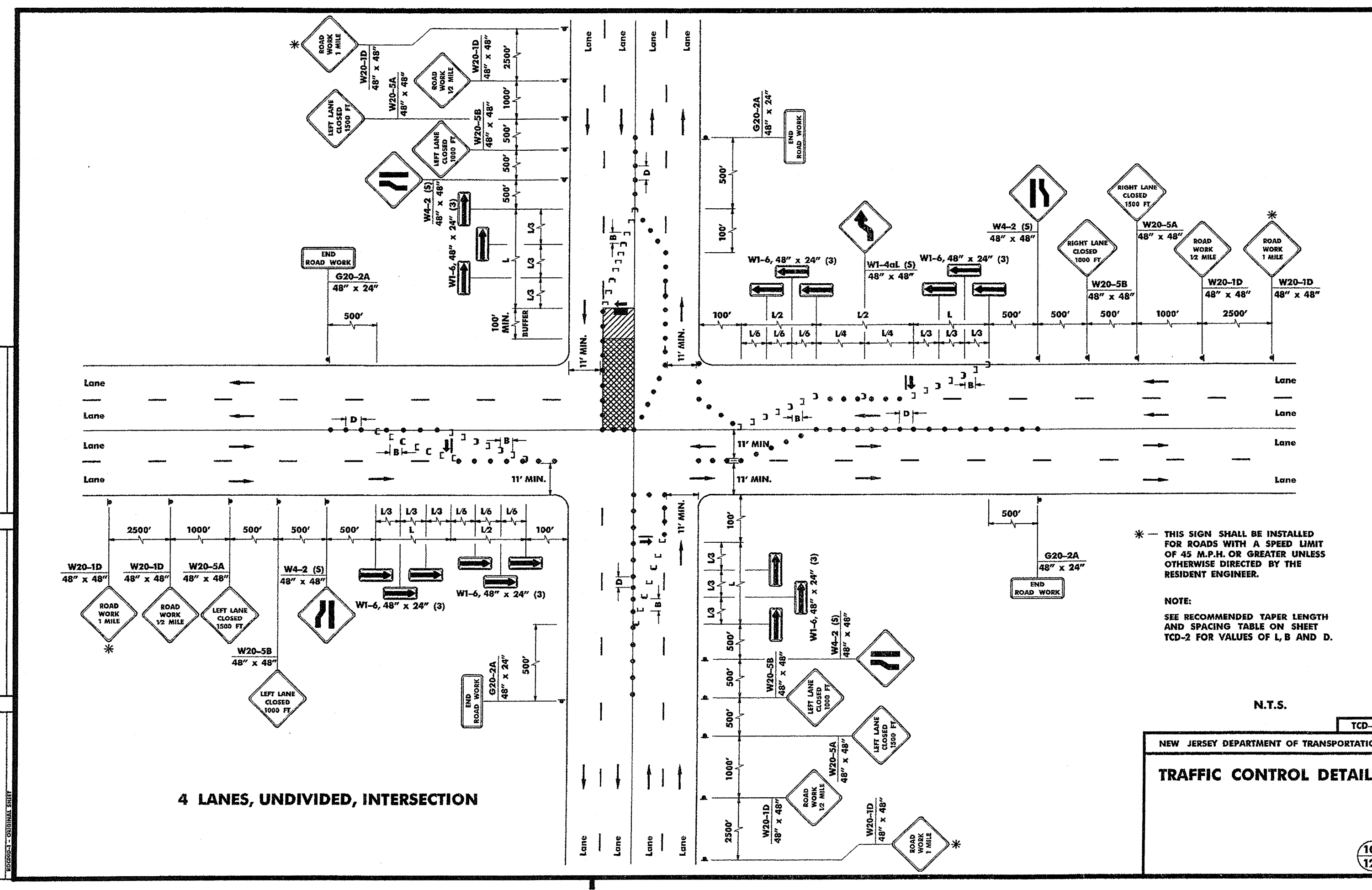

4 LANES, UNDIVIDED, INTERSECTION

* THIS SIGN SHALL BE INSTALLED FOR ROADS WITH A SPEED LIMIT OF 45 M.P.H. OR GREATER UNLESS OTHERWISE DIRECTED BY THE RESIDENT ENGINEER.

NOTE:
SEE RECOMMENDED TAPER LENGTH AND SPACING TABLE ON SHEET TCD-2 FOR VALUES OF L, B AND D.

N.T.S.

TCD-12
NEW JERSEY DEPARTMENT OF TRANSPORTATION
TRAFFIC CONTROL DETAILS

pen T2018 = Roadstop22.plottablet-2018.tbl
 scale =
 date =

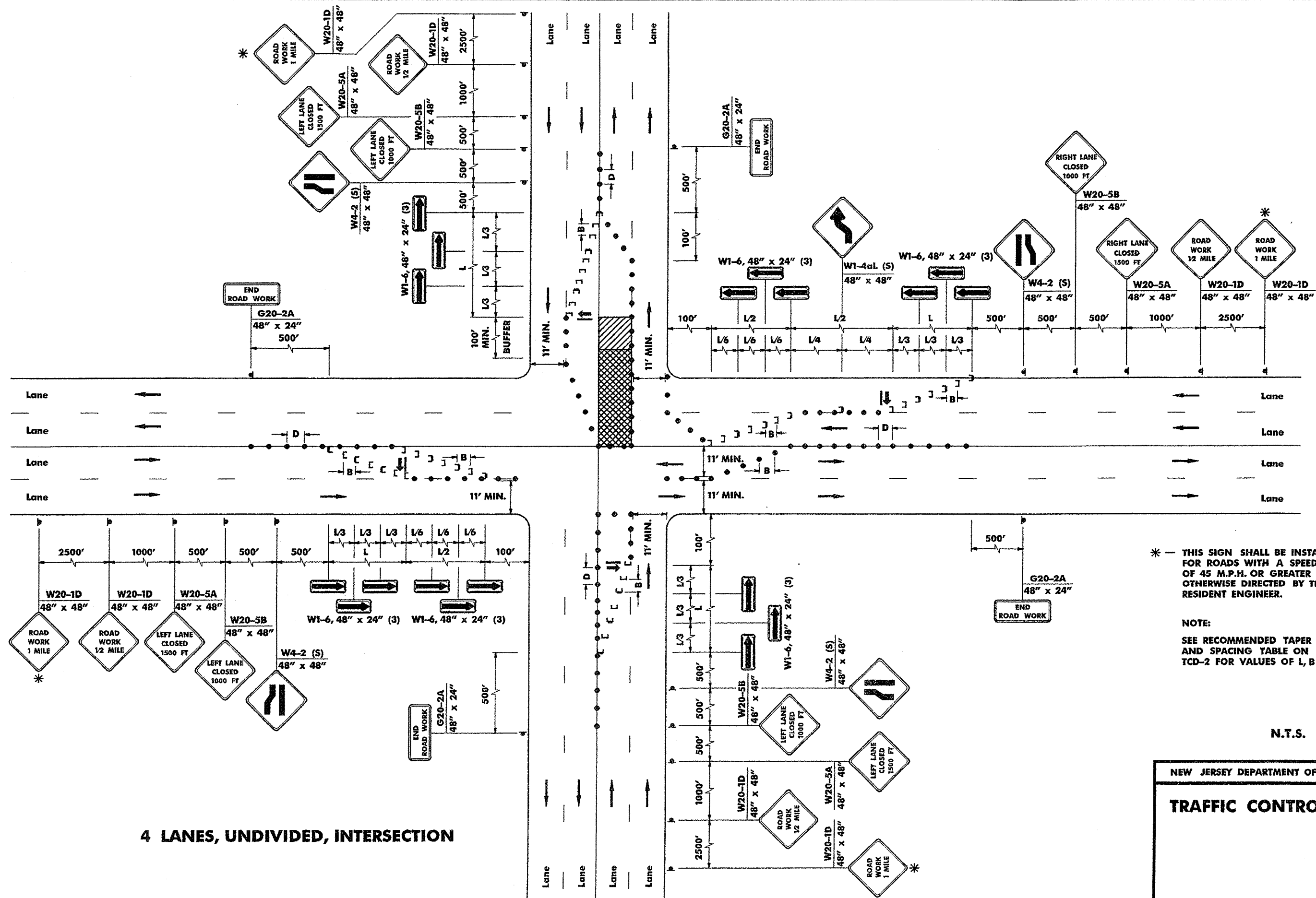

4 LANES, UNDIVIDED, INTERSECTION

* THIS SIGN SHALL BE INSTALLED FOR ROADS WITH A SPEED LIMIT OF 45 M.P.H. OR GREATER UNLESS OTHERWISE DIRECTED BY THE RESIDENT ENGINEER.

NOTE:
 SEE RECOMMENDED TAPER LENGTH AND SPACING TABLE ON SHEET TCD-2 FOR VALUES OF L, B AND D.

N.T.S.

NEW JERSEY DEPARTMENT OF TRANSPORTATION
TRAFFIC CONTROL DETAILS

TCD-13

Pen Table = A:\roadwork\plottable\scale.tbl
 scale =
 date =
 T10 =
 ORIGINAL SHEET

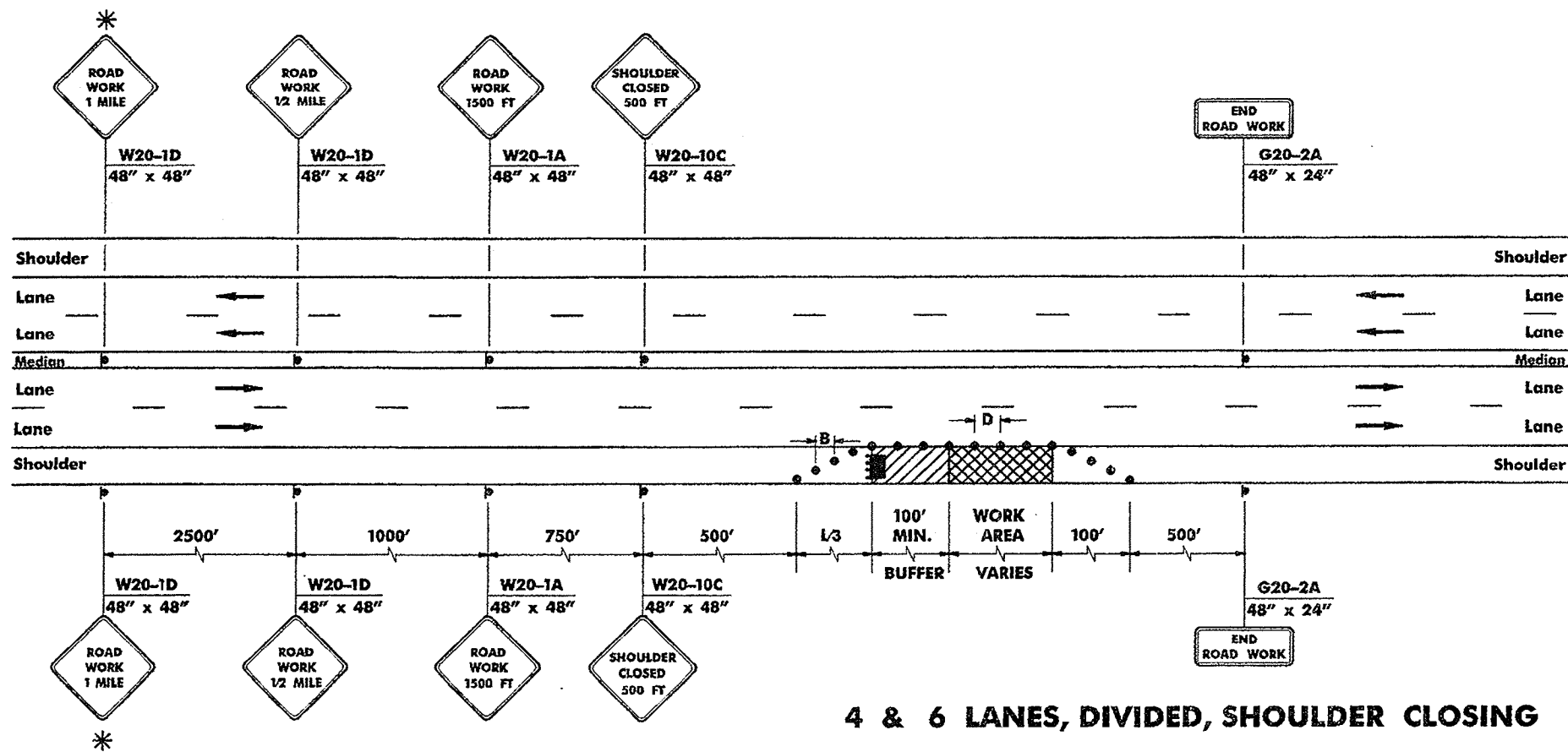
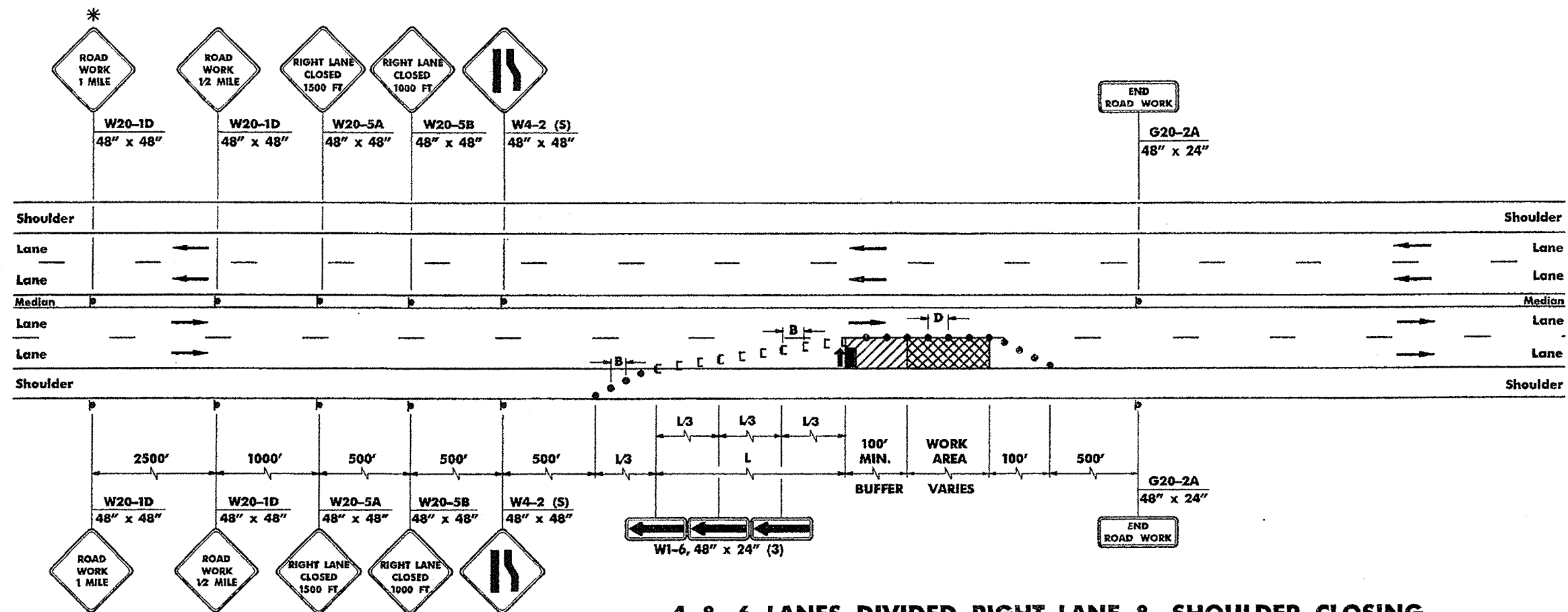

* — THIS SIGN SHALL BE INSTALLED FOR ROADS WITH A SPEED LIMIT OF 45 M.P.H. OR GREATER UNLESS OTHERWISE DIRECTED BY THE RESIDENT ENGINEER. FOR ROADS WITH A SPEED LIMIT GREATER THAN 55 M.P.H., A "ROAD WORK 2 MILES" SIGN SHALL ALSO BE INSTALLED 2 MILES IN ADVANCE OF LANE CLOSING UNLESS OTHERWISE DIRECTED BY THE RESIDENT ENGINEER.

NOTES:

1. IF MEDIAN IS NARROWER THAN WIDTH OF SIGN PLUS 2 FEET, OMIT MEDIAN SIGNING.
2. SEE RECOMMENDED TAPER LENGTH AND SPACING TABLE ON SHEET TCD-2 FOR VALUES OF L, B AND D.

N.T.S.

TCD-14

NEW JERSEY DEPARTMENT OF TRANSPORTATION

TRAFFIC CONTROL DETAILS

pen table = /...
 scale = ...
 date = ...
 title = ...
 108
 129

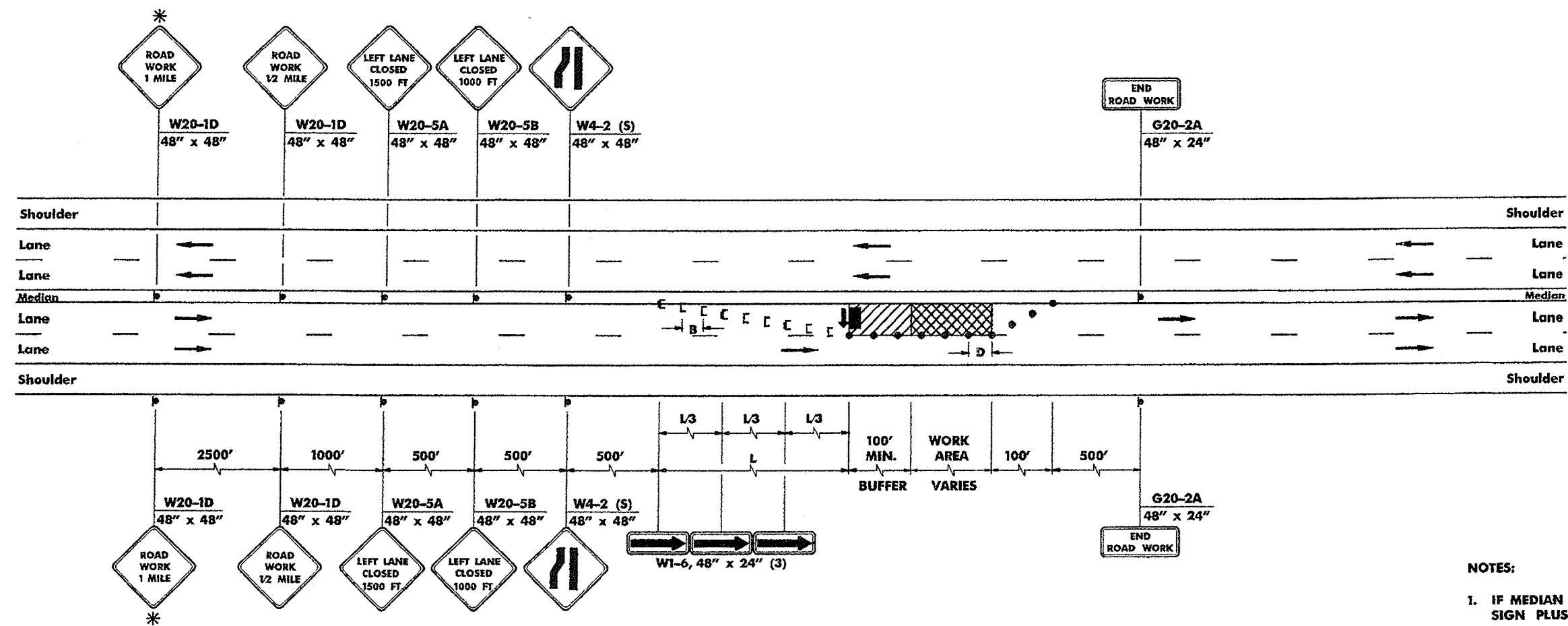

4 & 6 LANES, DIVIDED, LEFT LANE CLOSING

* — THIS SIGN SHALL BE INSTALLED FOR ROADS WITH A SPEED LIMIT OF 45 M.P.H. OR GREATER UNLESS OTHERWISE DIRECTED BY THE RESIDENT ENGINEER. FOR ROADS WITH A SPEED LIMIT GREATER THAN 55 M.P.H., A "ROAD WORK 2 MILES" SIGN SHALL ALSO BE INSTALLED 2 MILES IN ADVANCE OF LANE CLOSING UNLESS OTHERWISE DIRECTED BY THE RESIDENT ENGINEER.

NOTES:

1. IF MEDIAN IS NARROWER THAN WIDTH OF SIGN PLUS 2 FEET, OMIT MEDIAN SIGNING.
2. IF WORK INTERFERES WITH OPPOSING TRAFFIC, CLOSE OPPOSITE LEFT LANE USING SAME CONFIGURATION.
3. SEE RECOMMENDED TAPER LENGTH AND SPACING TABLE ON SHEET TCD-2 FOR VALUES OF L, B AND D.

N.T.S.

TCD-15

NEW JERSEY DEPARTMENT OF TRANSPORTATION

TRAFFIC CONTROL DETAILS

108
129

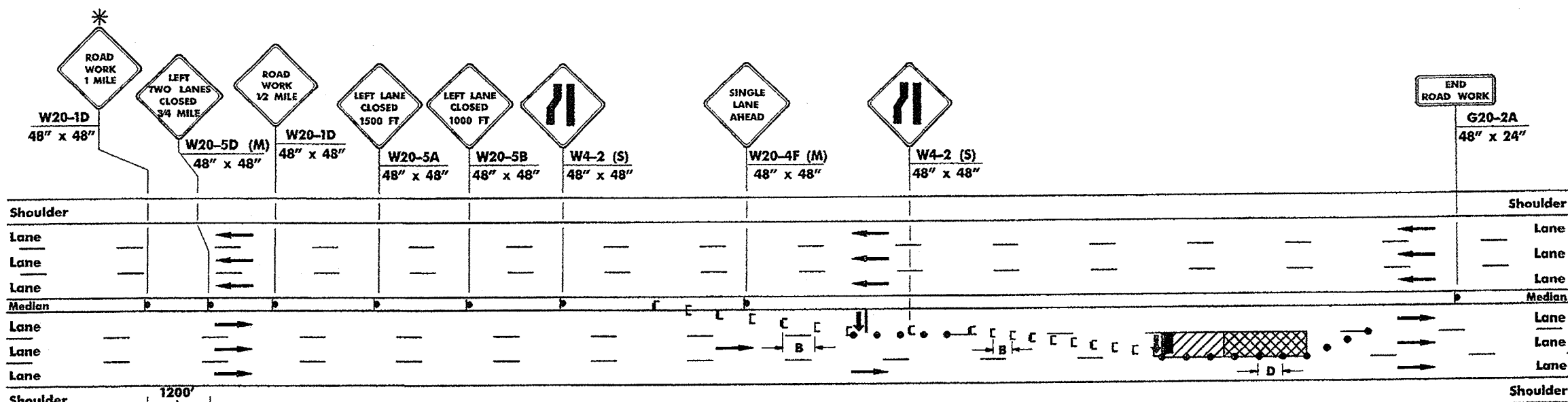

6 LANES, DIVIDED, LEFT TWO LANES CLOSING

* — THIS SIGN SHALL BE INSTALLED FOR ROADS WITH A SPEED LIMIT OF 45 M.P.H. OR GREATER UNLESS OTHERWISE DIRECTED BY THE RESIDENT ENGINEER. FOR ROADS WITH A SPEED LIMIT GREATER THAN 55 M.P.H., A "ROAD WORK 2 MILES" SIGN SHALL ALSO BE INSTALLED 2 MILES IN ADVANCE OF LANE CLOSING UNLESS OTHERWISE DIRECTED BY THE RESIDENT ENGINEER.

- NOTES:
1. IF MEDIAN IS NARROWER THAN WIDTH OF SIGN PLUS 2 FEET, OMIT MEDIAN SIGNING.
 2. SEE RECOMMENDED TAPER LENGTH AND SPACING TABLE ON SHEET TCD-2 FOR VALUES OF L, B AND D.

N.T.S.

TCD-16

NEW JERSEY DEPARTMENT OF TRANSPORTATION

TRAFFIC CONTROL DETAILS

RECORDS - ORIGINAL SHEET

- NOTES:
1. IF MEDIAN IS NARROWER THAN WIDTH OF SIGN PLUS 2 FEET, OMIT MEDIAN SIGNING.
 2. SEE RECOMMENDED TAPER LENGTH AND SPACING TABLE ON SHEET TCD-2 FOR VALUES OF L, B AND D.
 3. IF AN INTERCHANGE IS LOCATED EITHER WITHIN THE LIMITS OF THE CLOSURE OR WITHIN 1 MILE OF THE END OF THE CLOSURE, TEMPORARY GUIDE SIGN W(NJ) 100-1(L), "ALL EXITING TRAFFIC KEEP RIGHT (LEFT)" MUST BE PLACED ON BOTH SIDES OF THE ROADWAY AS FOLLOWS: 1200 FEET BEFORE SIGN W20-1D AND 500 FEET BEFORE SIGN W20-5A.

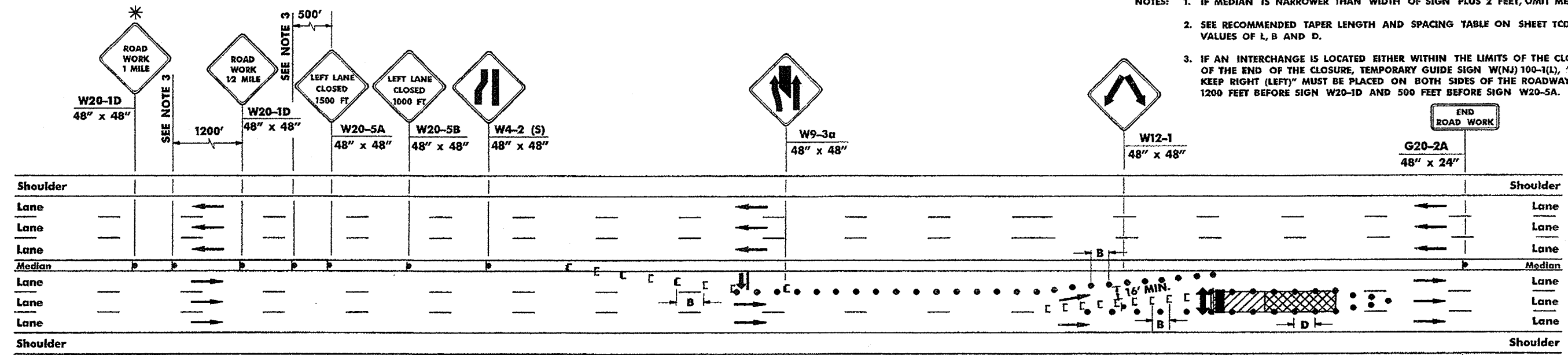

6 LANES, DIVIDED, CENTER LANE CLOSURE INITIATED BY LEFT LANE CLOSURE MAINTAIN 2 THROUGH LANES

* - THIS SIGN SHALL BE INSTALLED FOR ROADS WITH A SPEED LIMIT OF 45 M.P.H. OR GREATER UNLESS OTHERWISE DIRECTED BY THE RESIDENT ENGINEER. FOR ROADS WITH A SPEED LIMIT GREATER THAN 55 M.P.H., A "ROAD WORK 2 MILES" SIGN SHALL ALSO BE INSTALLED 2 MILES IN ADVANCE OF LANE CLOSING UNLESS OTHERWISE DIRECTED BY THE RESIDENT ENGINEER.

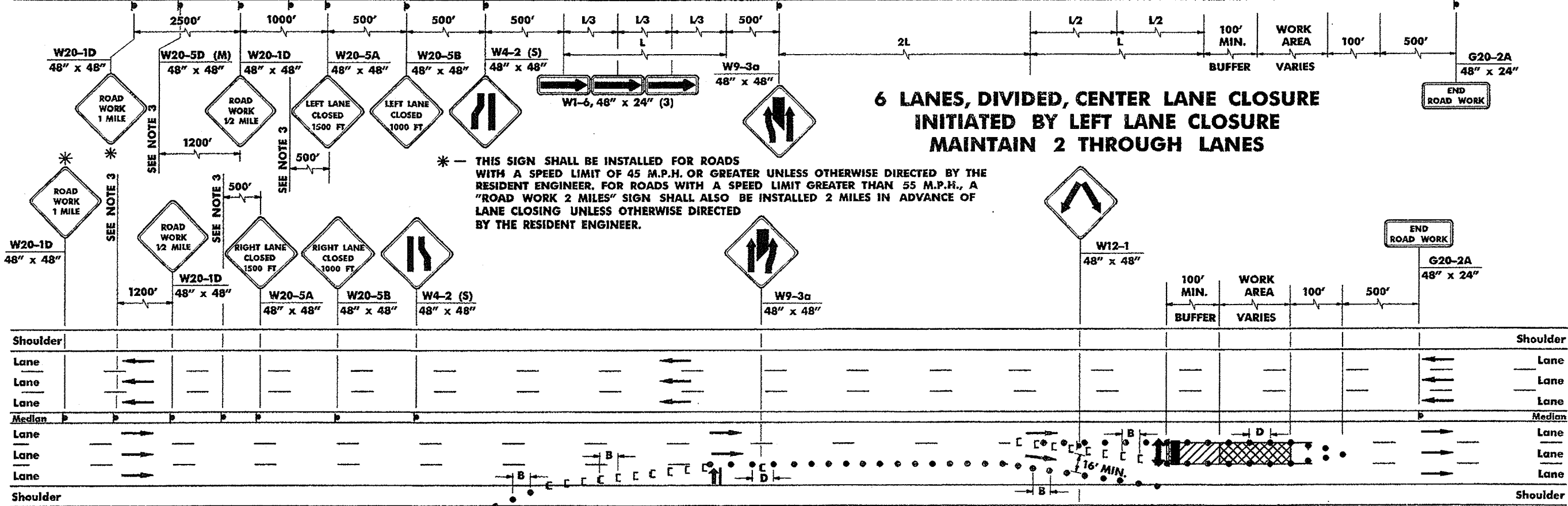

6 LANES, DIVIDED, CENTER LANE CLOSURE INITIATED BY RIGHT LANE CLOSURE MAINTAIN 2 THROUGH LANES

N.T.S.
NEW JERSEY DEPARTMENT OF TRANSPORTATION

TRAFFIC CONTROL DETAILS

TCD-17

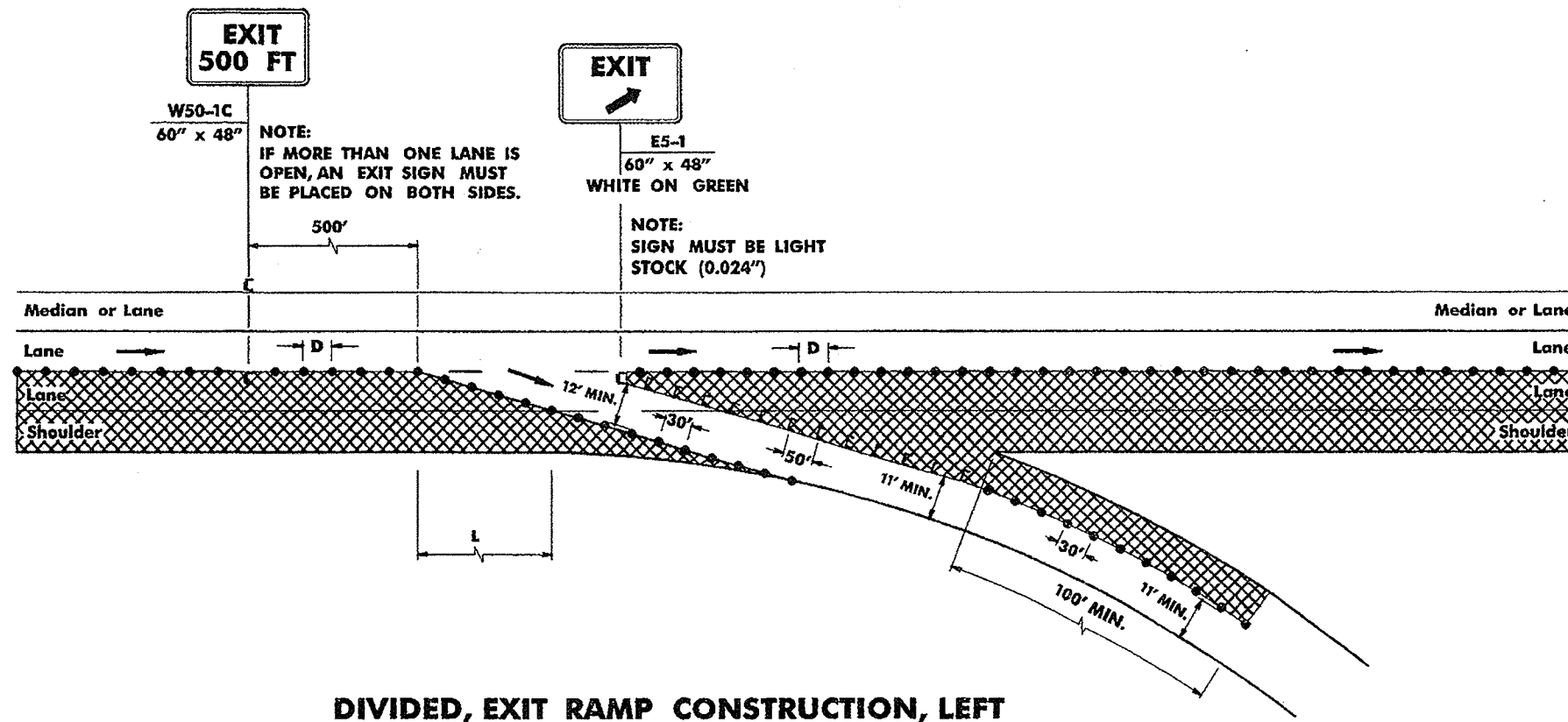

DIVIDED, EXIT RAMP CONSTRUCTION, LEFT

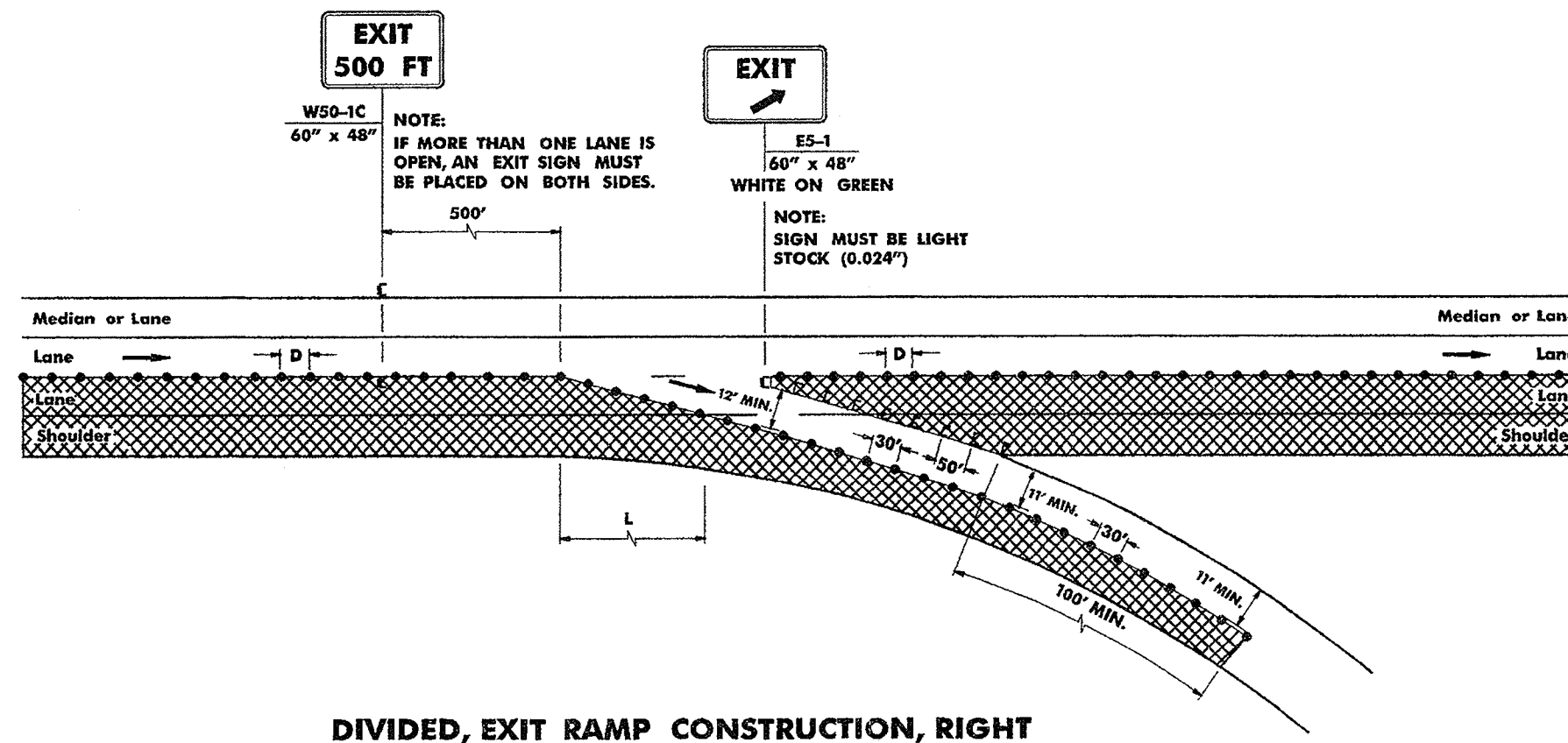

DIVIDED, EXIT RAMP CONSTRUCTION, RIGHT

NOTE:
SEE RECOMMENDED TAPER LENGTH
AND SPACING TABLE ON SHEET
TCD-2 FOR VALUES OF L, B AND D.

N.T.S.

TCD-18

NEW JERSEY DEPARTMENT OF TRANSPORTATION

TRAFFIC CONTROL DETAILS

pen table = /roadwork/plan/tables/traffic-control/

scale =

date =

file =

file =

file =

EXIT
500 FT

W50-1C
60" x 48"

NOTE:
IF MORE THAN ONE LANE IS OPEN, AN EXIT
SIGN MUST BE PLACED ON BOTH SIDES.

MATCH EXISTING DECELERATION LANE LENGTH

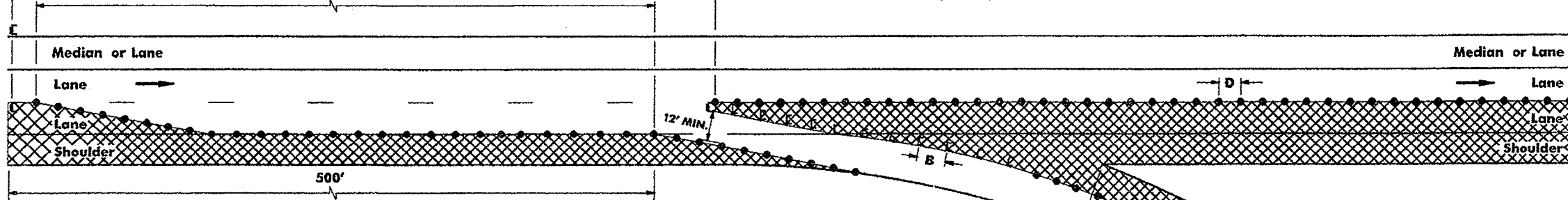

**DIVIDED, EXIT RAMP CONSTRUCTION, LEFT
WITH DECELERATION LANE**

EXIT
500 FT

W50-1C
60" x 48"

NOTE:
IF MORE THAN ONE LANE IS OPEN, AN EXIT
SIGN MUST BE PLACED ON BOTH SIDES.

MATCH EXISTING DECELERATION LANE LENGTH

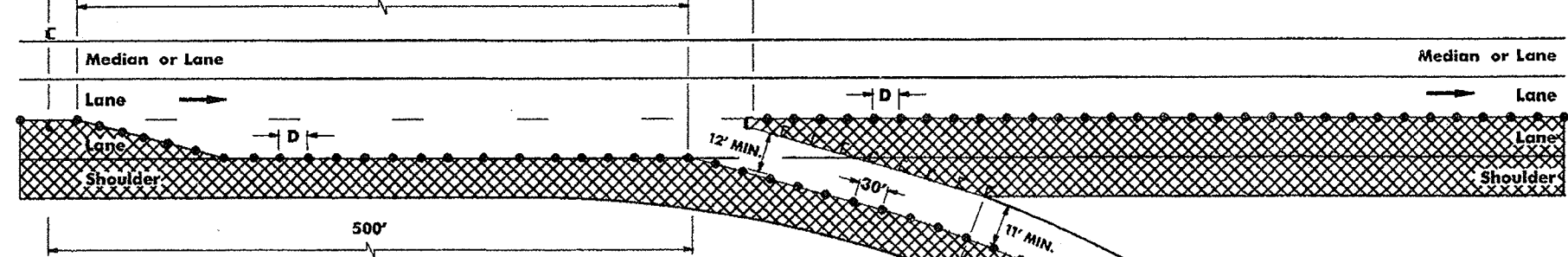

**DIVIDED, EXIT RAMP CONSTRUCTION, RIGHT
WITH DECELERATION LANE**

EXIT

E5-1
60" x 48"

WHITE ON GREEN
NOTE:
SIGN MUST BE LIGHT STOCK (0.024")

NOTE:
SEE RECOMMENDED TAPER LENGTH
AND SPACING TABLE ON SHEET
TCD-2 FOR VALUES OF L, B AND D.

N.T.S.

TCD-19

NEW JERSEY DEPARTMENT OF TRANSPORTATION

TRAFFIC CONTROL DETAILS

pen file = roadwork_plantable_half-scale.tbl
 scale =
 date =
 file =

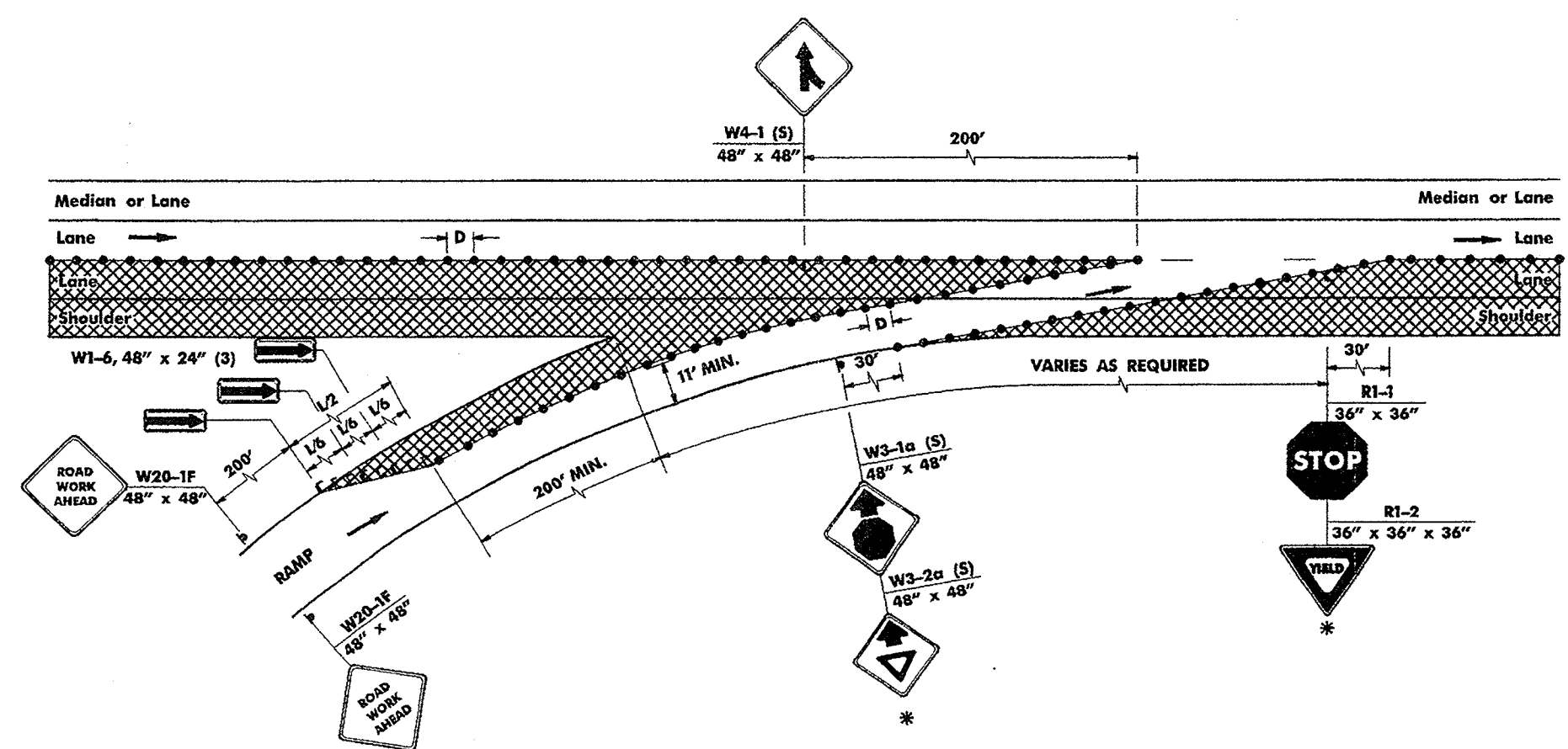

DIVIDED, ENTRANCE RAMP CONSTRUCTION, LEFT

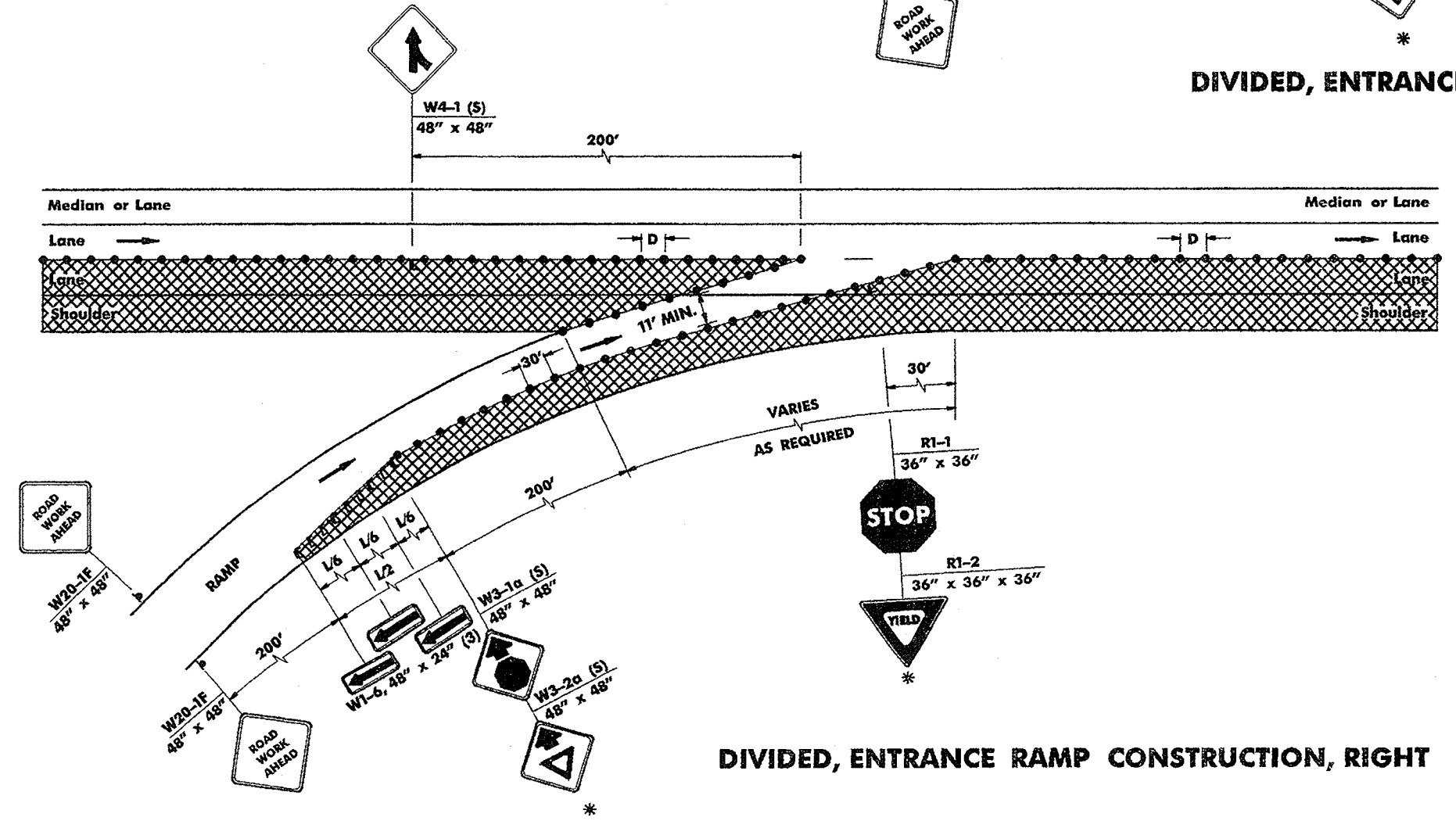

DIVIDED, ENTRANCE RAMP CONSTRUCTION, RIGHT

* — STOP SIGN OR YIELD SIGN TO BE DETERMINED BY REGIONAL TRAFFIC ENGINEER. SIGNS MUST BE LIGHT STOCK (0.024")

NOTE:

1. PROVIDE AN ACCELERATION LANE WHERE POSSIBLE. SEE TCD-20.
2. SEE RECOMMENDED TAPER LENGTH AND SPACING TABLE ON SHEET TCD-2 FOR VALUES OF L, B AND D.

N.T.S.

TCD-20
 NEW JERSEY DEPARTMENT OF TRANSPORTATION

TRAFFIC CONTROL DETAILS

pen table = /...
 scale =
 date =
 title =
 W =

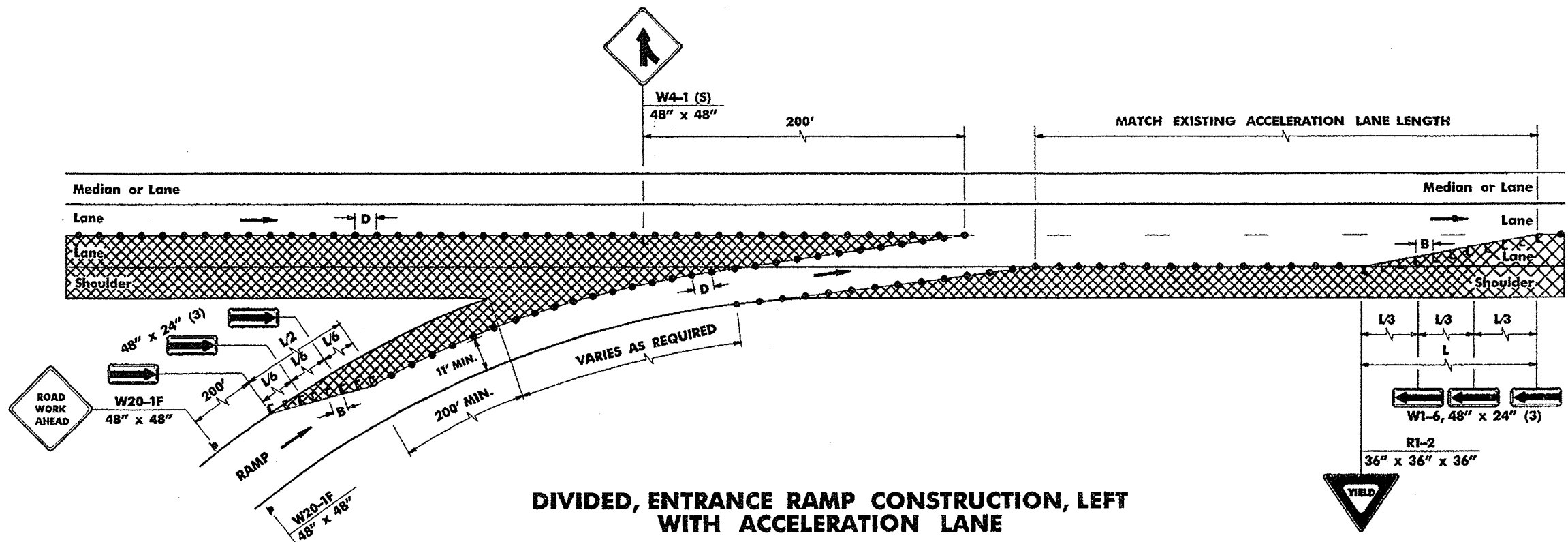

DIVIDED, ENTRANCE RAMP CONSTRUCTION, LEFT WITH ACCELERATION LANE

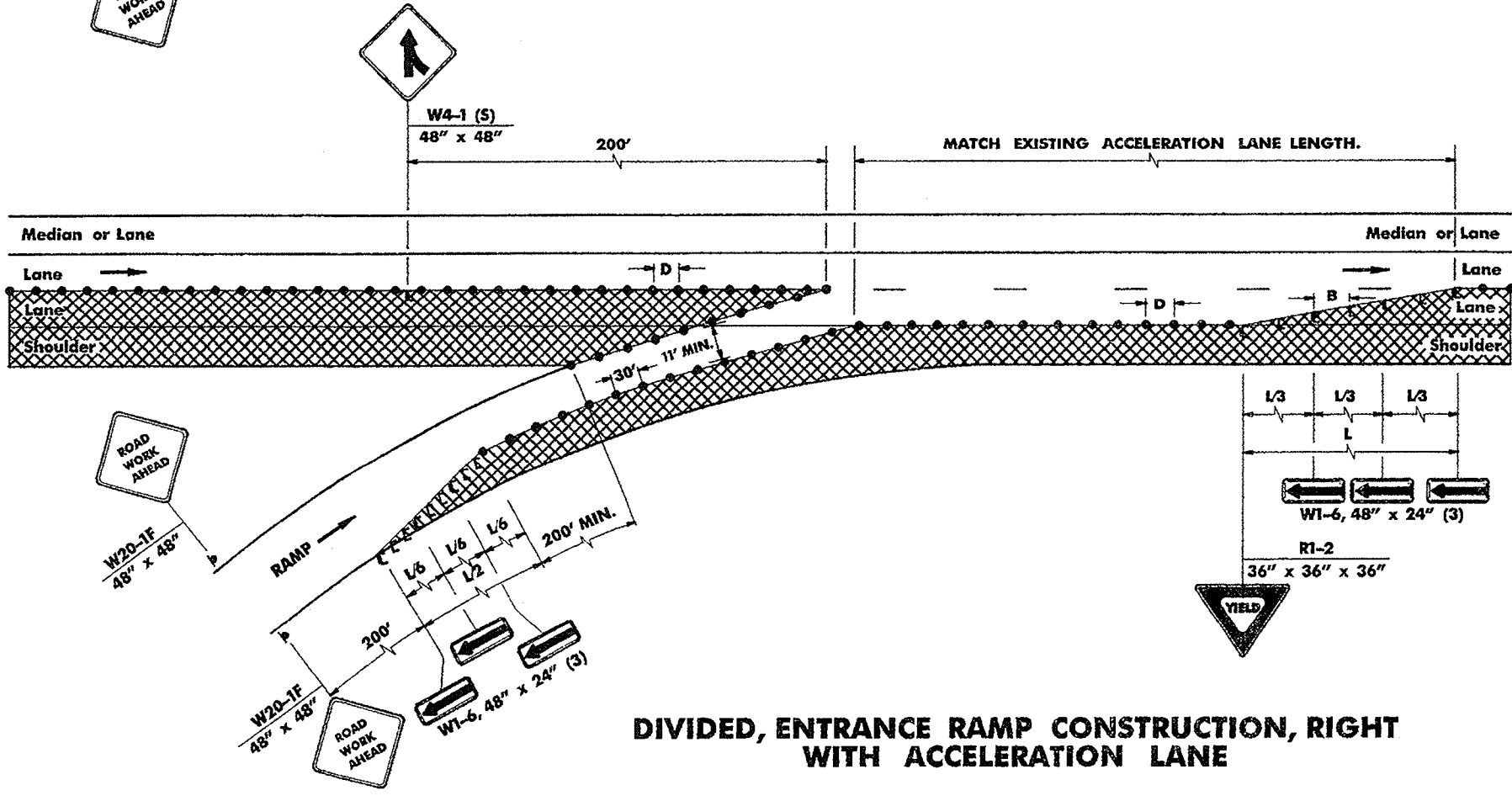

DIVIDED, ENTRANCE RAMP CONSTRUCTION, RIGHT WITH ACCELERATION LANE

NOTE:
 SEE RECOMMENDED TAPER LENGTH
 AND SPACING TABLE ON SHEET
 TCD-2 FOR VALUES OF L, B AND D.

N.T.S.

TCD-21

NEW JERSEY DEPARTMENT OF TRANSPORTATION

TRAFFIC CONTROL DETAILS

114
129

LEGEND

"W" IS THE WIDTH OF LANE CLOSURE IN FEET

"L" IS THE LENGTH OF TAPER

"#" IS NUMBER OF CONES IN TAPER AT 40' SPACING

LENGTH OF TAPER CHART FOR MOVING OPERATIONS

W	25 M.P.H.		30 M.P.H.		35 M.P.H.		40 M.P.H.		45 M.P.H.		50 M.P.H.		55 M.P.H.	
	L	#	L	#	L	#	L	#	L	#	L	#	L	#
1	10	2	15	2	20	2	30	2	45	3	50	3	55	3
2	25	2	30	2	45	3	55	3	90	4	100	4	110	4
3	35	2	45	3	65	3	80	3	135	5	150	5	165	5
4	45	3	60	3	85	4	110	4	180	6	200	6	220	7
5	55	3	75	3	105	4	135	5	225	7	250	7	275	8
6	65	3	90	4	125	5	160	5	270	8	300	9	330	9
10	105	4	150	5	205	6	270	8	450	13	500	14	550	15
11	115	4	165	5	225	7	295	9	495	14	550	15	605	16
12	125	5	180	6	245	7	320	9	540	15	600	16	660	18

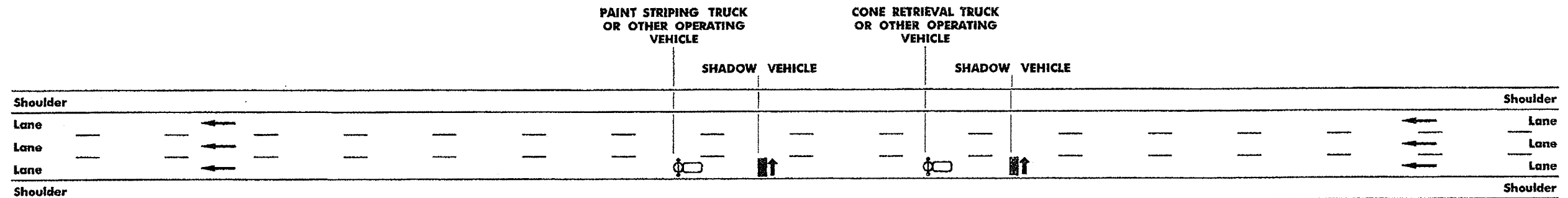

MULTI-LANE ROAD MOVING OPERATION

NOTE:

SHADOW VEHICLE SHALL MAINTAIN A DISTANCE OF 70 FEET MINIMUM TO A MAXIMUM OF 150 FEET BEHIND THE OPERATING VEHICLE.

N.T.S.

TCD-22

NEW JERSEY DEPARTMENT OF TRANSPORTATION

TRAFFIC CONTROL DETAILS

INDEX FOR STANDARD BRIDGE CONSTRUCTION DETAILS

DESCRIPTION	BCD	DESCRIPTION	BCD	DESCRIPTION	BCD
BRIDGE DECK REHABILITATION WITH CONCRETE OVERLAY	1A				
BRIDGE DECK REHABILITATION WITHOUT CONCRETE OVERLAY	1B				
BRIDGE DECK REHABILITATION, DECK JOINT REPAIR (SHEET 1 OF 2)	1C				
BRIDGE DECK REHABILITATION, DECK JOINT REPAIR (SHEET 2 OF 2)	1D				
STRIP SEAL DECK JOINTS	2				
2'-8", 2'-10", AND 6'-6" PARAPETS	3				
BRIDGE MEDIAN BARRIER	4				
SAWCUT GROOVING FOR BRIDGE DECKS	5				
CONCRETE CLASSES AND PAY ITEMS	6				
MISCELLANEOUS BRIDGE ITEMS	7				
BRIDGE CHAIN LINK FENCE (CURVED TOP)	8A				
BRIDGE CHAIN LINK FENCE (6'-3" HIGH)	8B				
STAY-IN-PLACE FORMS	9				

BD00021 - ORIGINAL SHEET

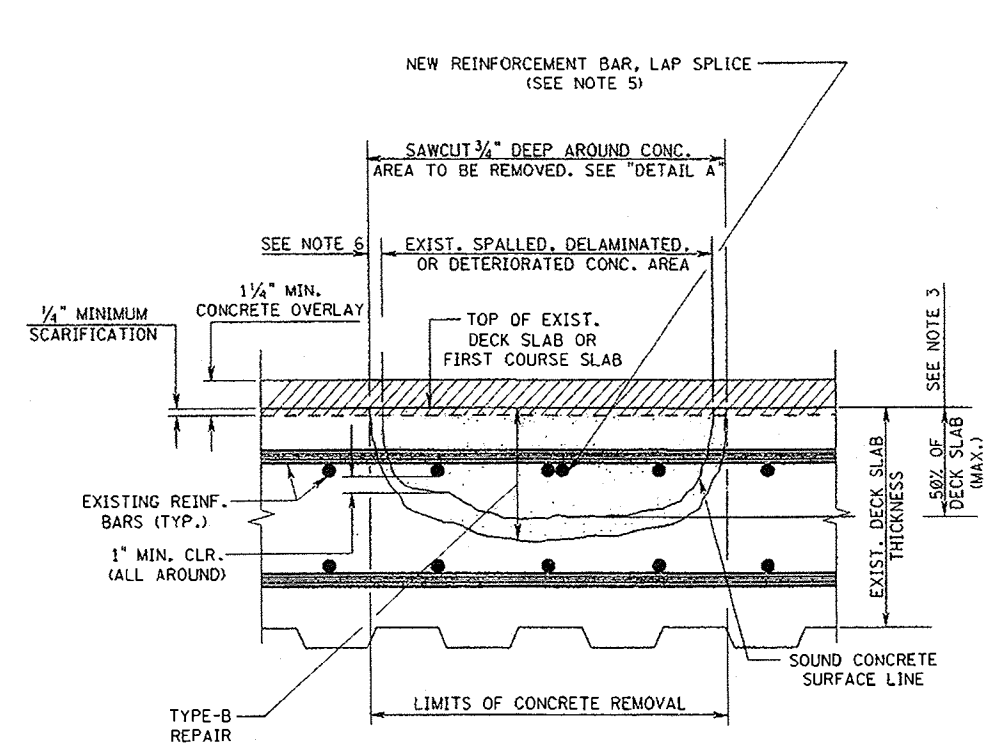

REPAIR TYPE-B
(SEE NOTE 2)

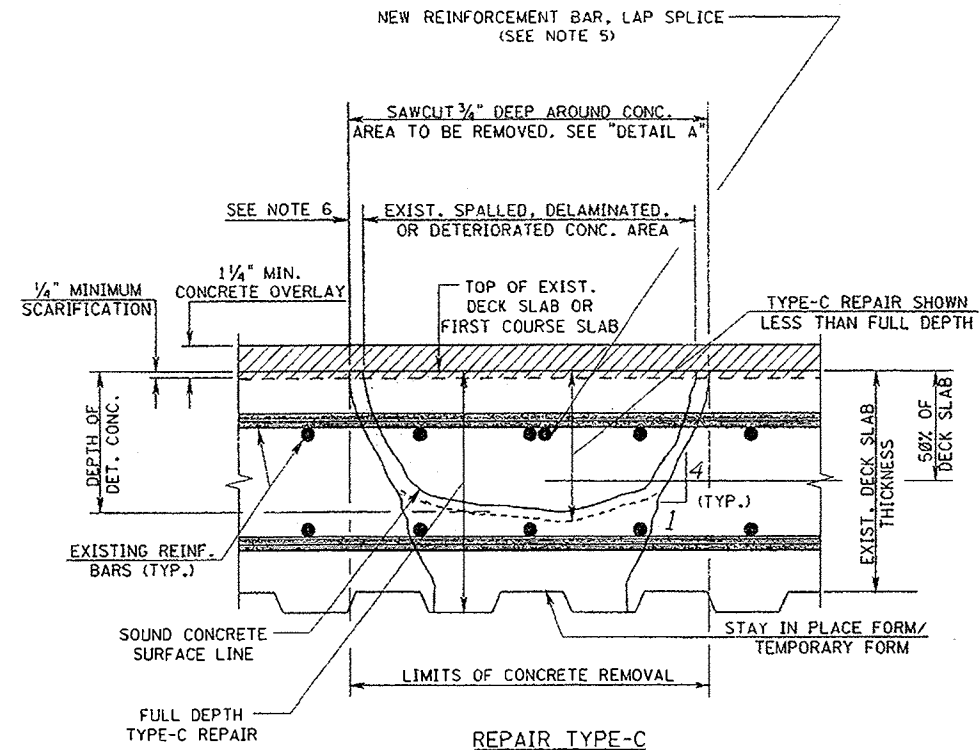

REPAIR TYPE-C
(SEE NOTE 3)

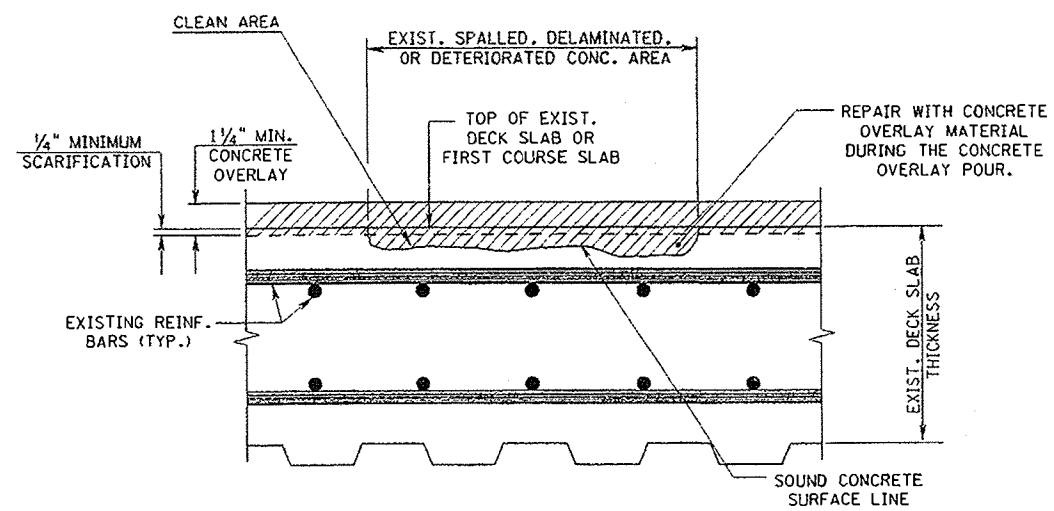

TYPICAL REPAIR DETAIL FOR MINOR SPALLED AREAS
(SEE NOTE 1)

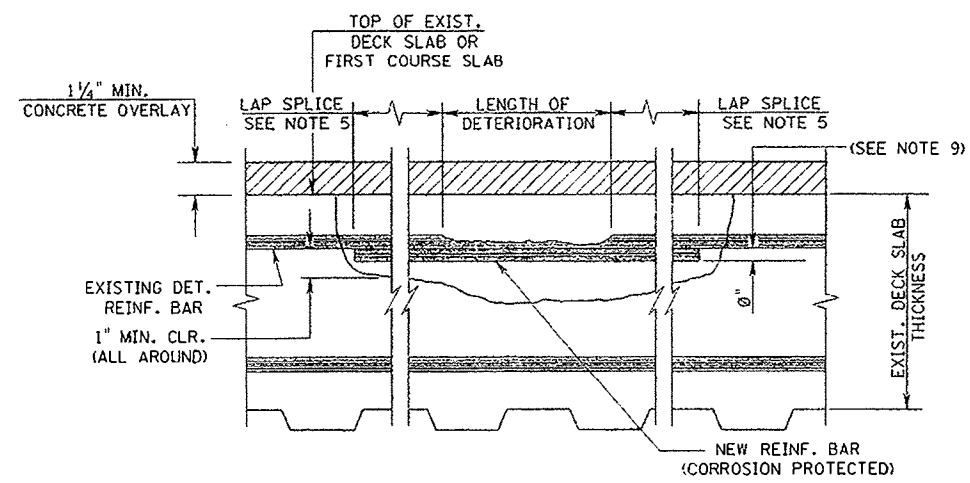

DETERIORATED REINFORCEMENT BAR REPAIR

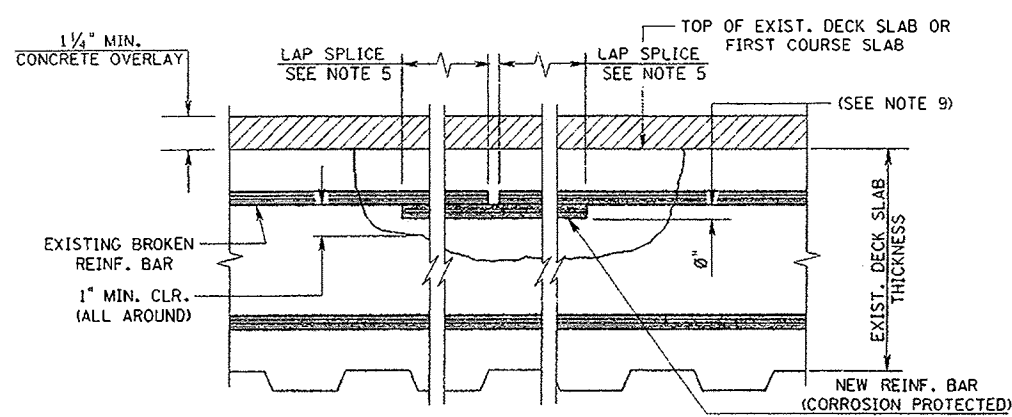

BROKEN REINFORCEMENT BAR REPAIR

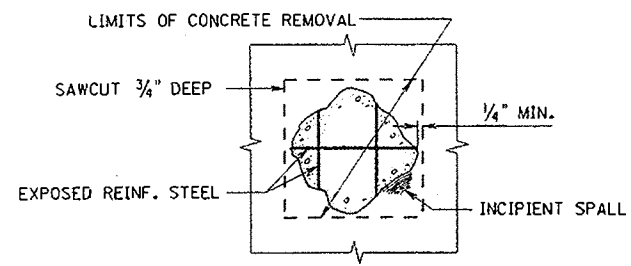

LIMITS OF REPAIR AREA (PLAN VIEW)
(SEE NOTE 7)

DETAIL A

GENERAL NOTES:

1. SPALLED, DELAMINATED, AND DETERIORATED CONCRETE AREAS SHALL BE CLEANED AND REPAIRED WITH THE CONCRETE OVERLAY TYPE THAT IS TO BE USED FOR THE OVERLAY PLACEMENT, OR CLASS A CONCRETE MAY BE USED. REFER TO NJDOT SPECIFICATIONS SECTION 518.
2. REPAIR TYPE-B: ALL DETERIORATED AND DELAMINATED CONCRETE SHALL BE REMOVED TO A MINIMUM DEPTH OF 1" BELOW THE BOTTOM OF THE TOP LAYER OF EXISTING REINFORCEMENT STEEL TO A MAXIMUM OF 50% OF THE THICKNESS OF THE EXISTING CONCRETE DECK.
3. REPAIR TYPE-C: ALL DETERIORATED AND DELAMINATED CONCRETE SHALL BE REMOVED, AND IF THE SOUND CONCRETE SURFACE IS LOCATED AT A DEPTH GREATER THAN 50% OF THE DECK THICKNESS WHEN MEASURED FROM THE TOP OF THE DECK, PERFORM TYPE-C REPAIR UPON APPROVAL OF THE ENGINEER, AS SHOWN IN THE DETAIL "REPAIR TYPE-C". IF THE BOTTOM MAT OF THE DECK REINFORCEMENT STEEL IS EXPOSED, THE DECK SLAB SHALL BE REPLACED TO FULL DEPTH IN THIS AREA OF EXPOSURE.
4. THE TOP SURFACE OF THE CONCRETE FOR TYPE-B AND TYPE-C REPAIRS SHALL BE EVEN WITH THE ADJACENT TOP OF EXISTING DECK SLAB AND SHALL MAINTAIN THE EXISTING GRADES AND CROSS SLOPES.
5. A NEW CORROSION PROTECTED REINFORCEMENT BAR SHALL BE PLACED TO SUPPLEMENT AN EXISTING REINFORCEMENT BAR WHEN AN EXISTING BAR HAS A SECTION LOSS OF 25% OR MORE OF THE ORIGINAL CROSS SECTION, AS DETERMINED BY THE ENGINEER, OR THE EXISTING REINFORCEMENT BAR IS BROKEN. THE NEW BAR SHALL EXTEND 30 BAR DIAMETERS IN EACH DIRECTION FROM WHERE THE SECTION LOSS OR BREAK ENDS. MODIFY THE LIMITS OF THE REPAIR AREA TO MEET THE REINFORCEMENT SPLICE LAP REQUIREMENTS.
6. FOR REPAIR TYPE-B AND TYPE-C SOUND CONCRETE SHALL BE REMOVED TO A DEPTH OF 1/4" MINIMUM TO 1" MAXIMUM IN ALL DIRECTIONS, EXCEPT THAT THE MAXIMUM LIMIT MAY BE MODIFIED UPON APPROVAL OF THE ENGINEER.
7. UPON APPROVAL OF THE ENGINEER, MODIFY THE LIMITS OF CONCRETE REMOVAL AS SHOWN IN THE "LIMITS OF REPAIR AREA (PLAN VIEW)" WHEN SUPPLEMENTARY REINFORCEMENT BARS ARE REQUIRED.
8. DECK REINFORCEMENT BAR DETAILS SHOWN ARE GENERAL. ACTUAL REINFORCEMENT BAR SPACINGS AND LOCATIONS WILL VARY FROM BRIDGE TO BRIDGE.
9. THE NEW REINFORCEMENT BAR SHALL BE PLACED AT THE SAME LEVEL ALONGSIDE THE EXISTING DETERIORATED OR BROKEN REINFORCEMENT BAR.
10. BEFORE PLACEMENT OF THE OVERLAY, ALL PREVIOUSLY PATCHED AREAS SHALL BE COMPLETELY REMOVED.

BCD-1A

NEW JERSEY DEPARTMENT OF TRANSPORTATION

BRIDGE CONSTRUCTION DETAILS
BRIDGE DECK REHABILITATION
WITH CONCRETE OVERLAY

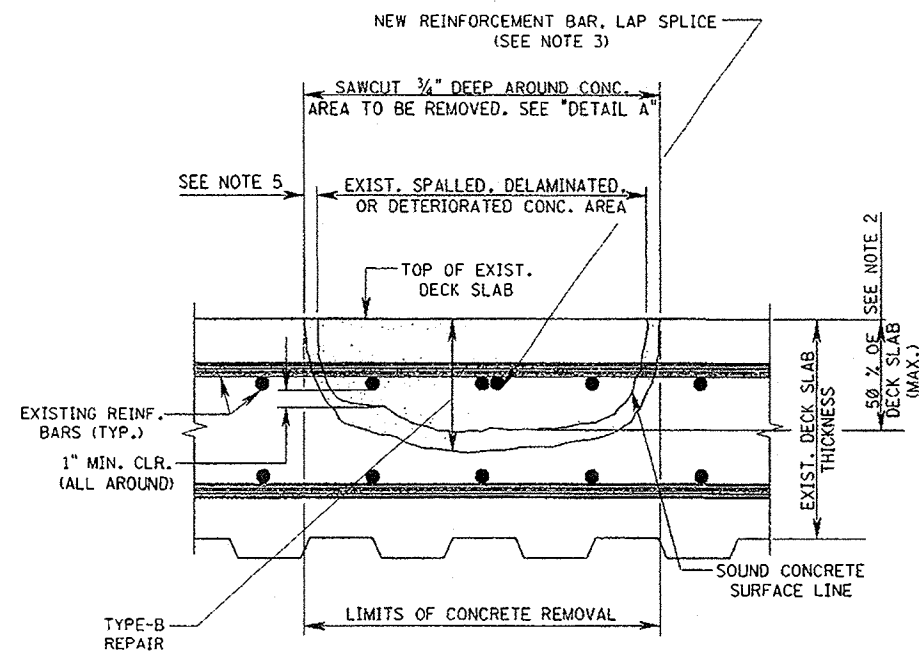

REPAIR TYPE-B
(SEE NOTE 1)

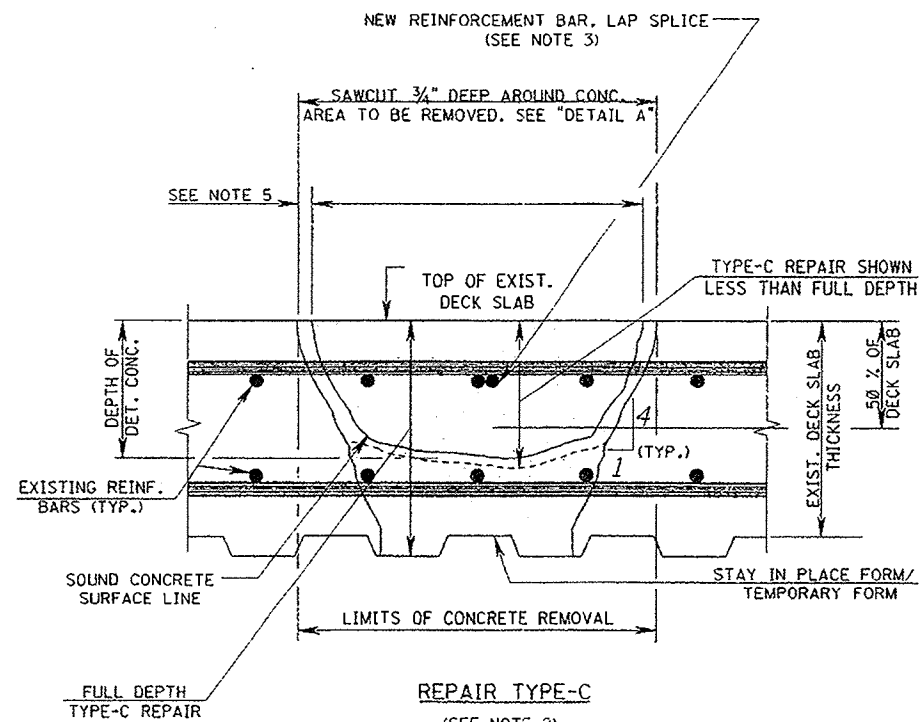

REPAIR TYPE-C
(SEE NOTE 2)

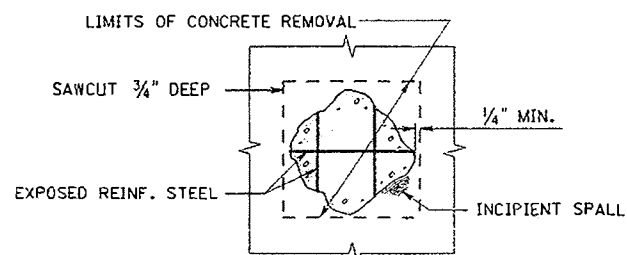

LIMITS OF REPAIR AREA (PLAN VIEW)
(SEE NOTE 6)

DETAIL A

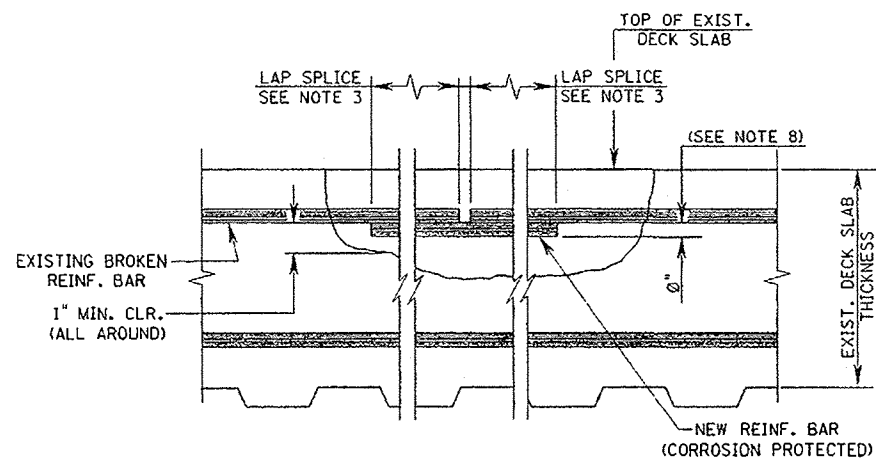

BROKEN REINFORCEMENT BAR REPAIR

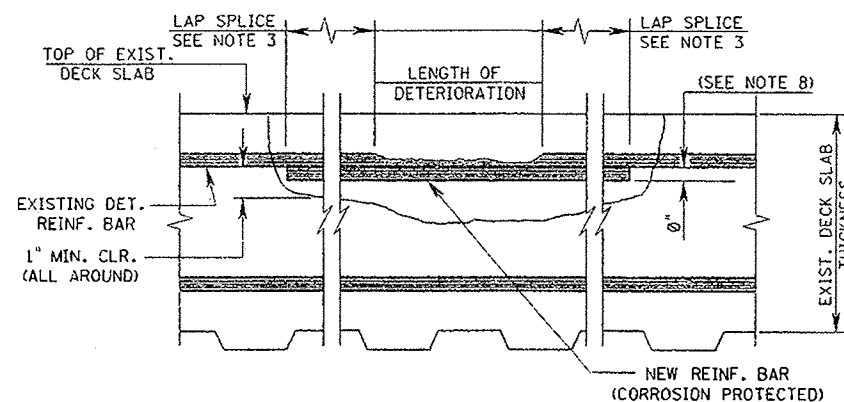

DETERIORATED REINFORCEMENT BAR REPAIR

GENERAL NOTES

1. REPAIR TYPE-B: ALL DETERIORATED AND DELAMINATED CONCRETE SHALL BE REMOVED TO A MINIMUM DEPTH OF 1" BELOW THE BOTTOM OF THE TOP LAYER OF EXISTING REINFORCEMENT STEEL OR UP TO A MAXIMUM OF 50% OF THE THICKNESS OF THE EXISTING CONCRETE DECK.
2. REPAIR TYPE-C: ALL DETERIORATED AND DELAMINATED CONCRETE SHALL BE REMOVED. IF THE SOUND CONCRETE SURFACE IS LOCATED AT A DEPTH GREATER THAN 50% OF THE DECK THICKNESS WHEN MEASURED FROM THE TOP OF THE DECK, PERFORM TYPE-C REPAIR UPON APPROVAL OF THE ENGINEER, AS SHOWN IN THE DETAIL "REPAIR TYPE-C". IF THE BOTTOM MAT OF THE DECK REINFORCEMENT STEEL IS EXPOSED, THE DECK SLAB SHALL BE REPLACED TO FULL DEPTH IN THIS AREA OF EXPOSURE.
3. A NEW CORROSION PROTECTED REINFORCEMENT BAR SHALL BE PLACED TO SUPPLEMENT AN EXISTING REINFORCEMENT BAR WHEN AN EXISTING BAR HAS A SECTION LOSS OF 25% OR MORE OF THE ORIGINAL CROSS SECTION, AS DETERMINED BY THE ENGINEER, OR THE EXISTING REINFORCEMENT BAR IS BROKEN. THE NEW BAR SHALL EXTEND 3Ø BAR DIAMETERS IN EACH DIRECTION FROM WHERE THE SECTION LOSS OR BREAK ENDS. MODIFY THE LIMITS OF THE REPAIR AREA TO MEET THE REINFORCEMENT SPLICE LAP REQUIREMENTS.
4. THE TOP SURFACE OF THE CONCRETE FOR TYPE-B AND TYPE-C REPAIRS SHALL BE EVEN WITH THE ADJACENT TOP OF EXISTING DECK SLAB AND SHALL MAINTAIN THE EXISTING GRADES AND CROSS SLOPES.
5. FOR REPAIR TYPE-B AND TYPE-C SOUND CONCRETE SHALL BE REMOVED TO A DEPTH OF 1/4" MINIMUM TO 1" MAXIMUM IN ALL DIRECTIONS, EXCEPT THAT THE MAXIMUM LIMIT MAY BE MODIFIED UPON APPROVAL OF THE ENGINEER.
6. UPON APPROVAL OF THE ENGINEER, MODIFY THE LIMITS OF CONCRETE REMOVAL AS SHOWN IN THE "LIMITS OF REPAIR AREA (PLAN VIEW)" WHEN SUPPLEMENTARY REINFORCEMENT BARS ARE REQUIRED.
7. DECK REINFORCEMENT BAR DETAILS SHOWN ARE GENERAL. ACTUAL REINFORCEMENT BAR SPACINGS AND LOCATIONS WILL VARY FROM BRIDGE TO BRIDGE.
8. THE NEW REINFORCEMENT BAR SHALL BE PLACED AT THE SAME LEVEL ALONGSIDE THE EXISTING DETERIORATED OR BROKEN REINFORCEMENT BAR.
9. REFER TO THE NJDOT SPECIFICATIONS SECTION 518 FOR GUIDANCE AS TO THE SELECTION OF A QUICK-SETTING PATCH MATERIAL PRODUCT.

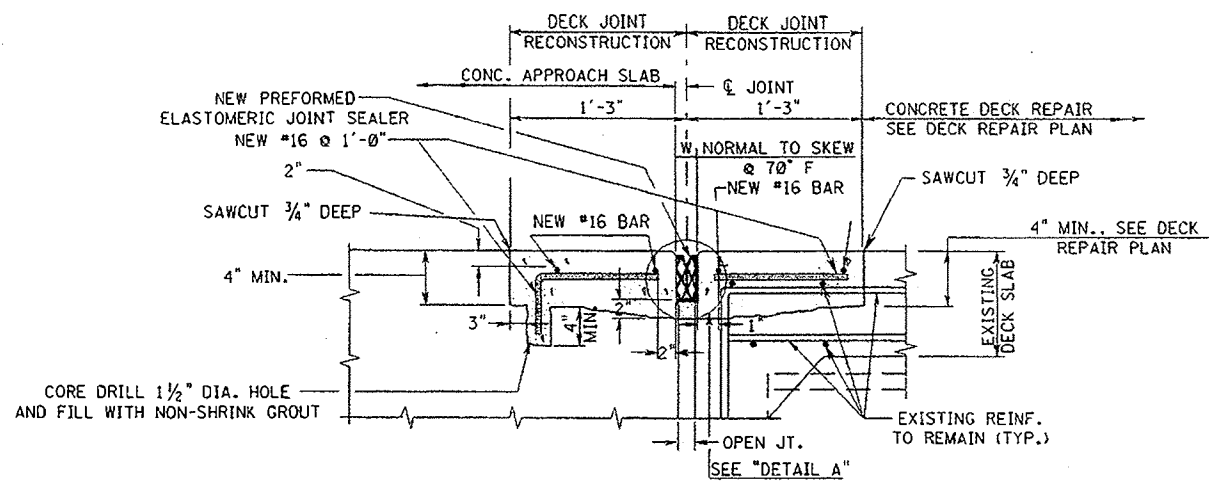

DECK JOINT AT ABUTMENT WITH APPROACH SLAB

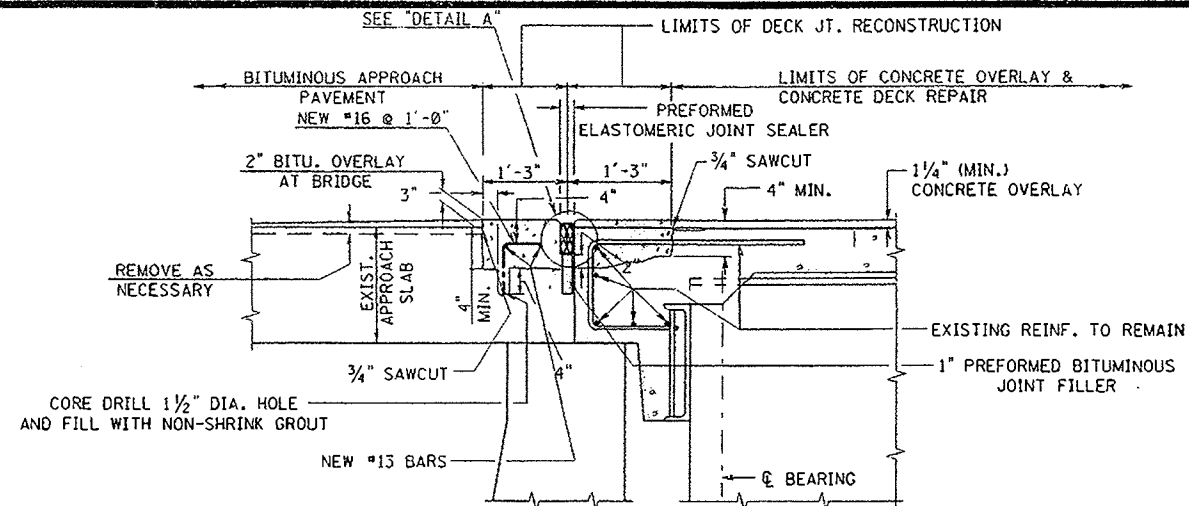

DECK JOINT AT ABUTMENT (WITH APPROACH SLAB AND CONCRETE OVERLAY)

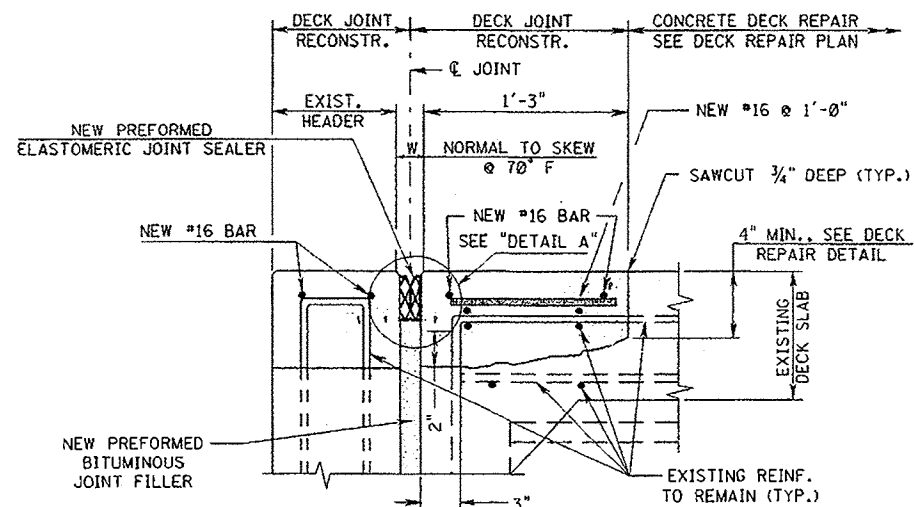

DECK JOINT AT ABUTMENT WITH HEADER

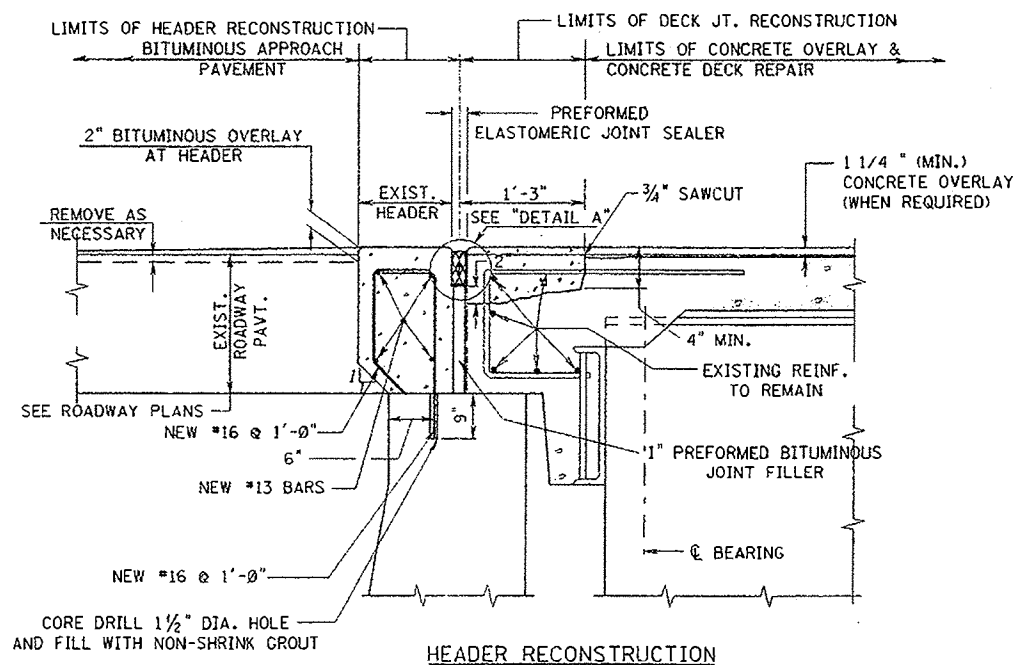

HEADER RECONSTRUCTION

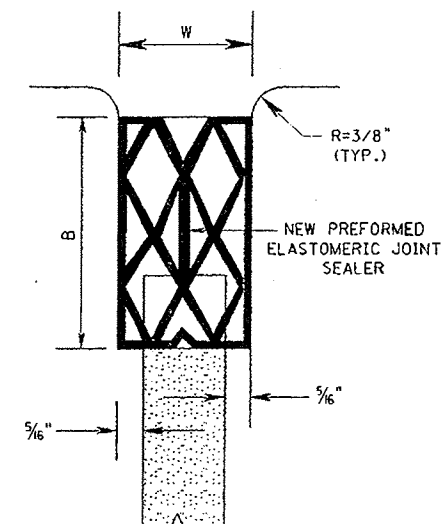

DIMENSIONS W AND B VARY DEPENDING ON THE JOINT SEALER MANUFACTURER.

DETAIL A

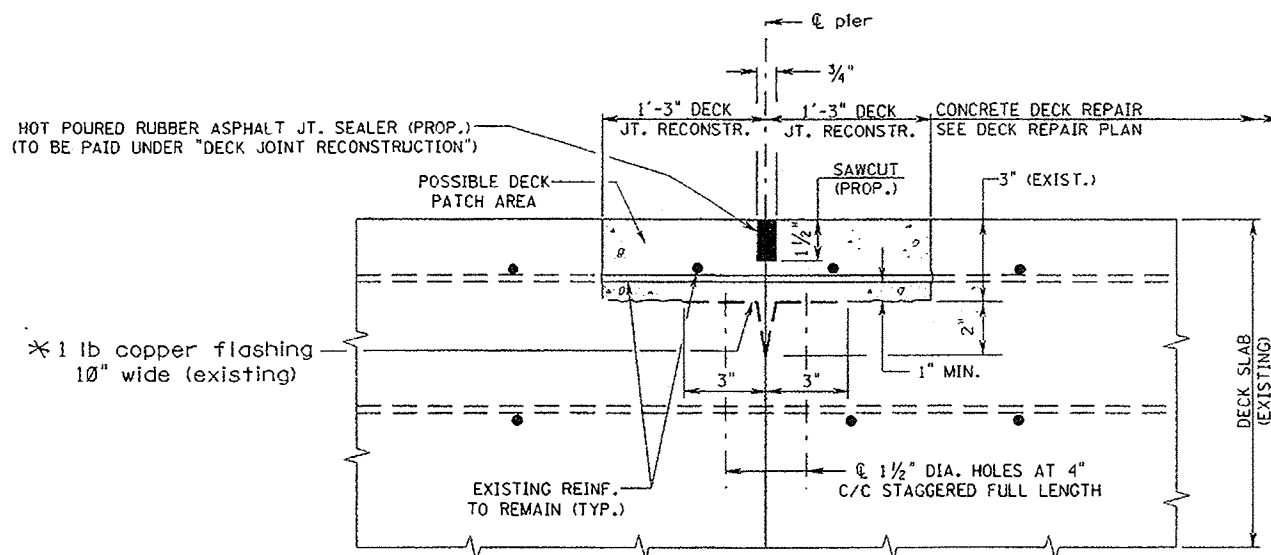

FIXED DECK JOINT AT PIER

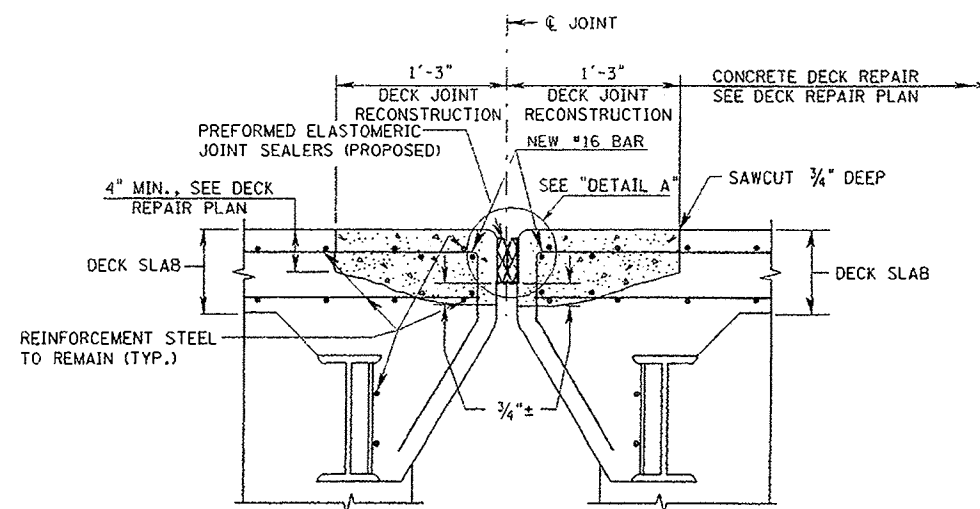

EXP. DECK JOINT AT PIER

GENERAL NOTES:

1. ALL NEW REINFORCEMENT BARS ARE IN METRIC UNITS AND SHALL BE CORROSION PROTECTED. FOR ADDITIONAL NOTES, SEE BCD-1D.
2. MECHANICAL COUPLERS MAY BE NECESSARY IF CONSTRUCTION IS STAGED.
3. PROVIDE AS REQUIRED ARMORED JOINT.

BCD-1C

NEW JERSEY DEPARTMENT OF TRANSPORTATION

BRIDGE CONSTRUCTION DETAILS

BRIDGE DECK REHABILITATION
DECK JOINT REPAIR
(SHEET 1 OF 2)

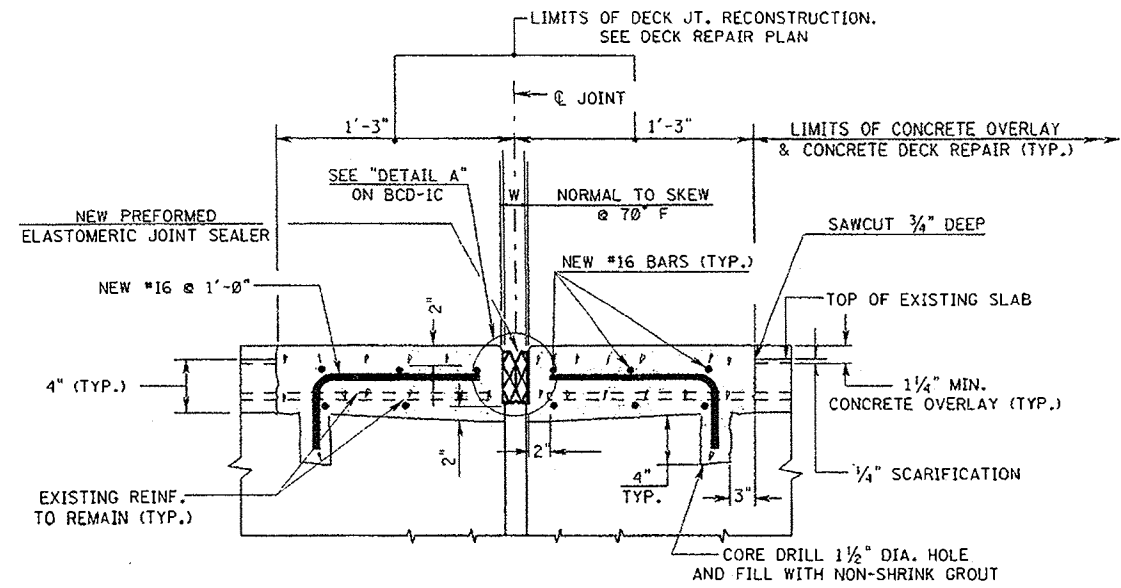

EXPANSION DECK JOINT AT PIER WITH CONCRETE OVERLAY

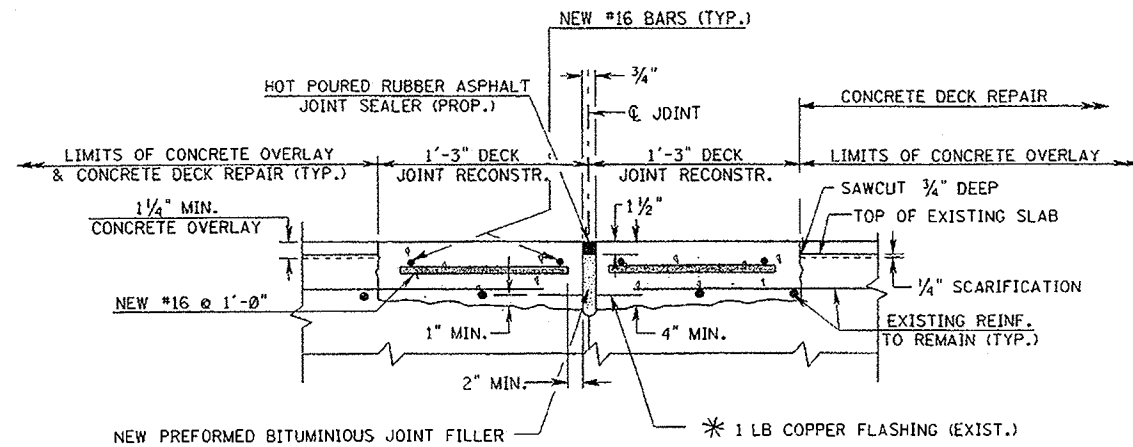

FIXED JOINT AT PIER WITH CONCRETE OVERLAY.

* THE CONTRACTOR SHALL REPLACE THE EXISTING COPPER FLASHING DURING DECK JOINT RECONSTRUCTION ONLY IF THE CONCRETE BELOW COPPER FLASHING IS DETERIORATED OR IF EXISTING REINFORCEMENT IS LESS THAN 1" ABOVE TOP OF FLASHING. PAY UNDER ITEM "DECK JOINT RECONSTRUCTION".

GENERAL NOTES:

1. ALL NEW REINFORCEMENT BARS ARE IN METRIC UNITS AND SHALL BE CORROSION PROTECTED.
2. "DECK JOINT RECONSTRUCTION" AND "HEADER RECONSTRUCTION" SHALL INCLUDE:
 - A. 3/4" SAWCUT AS SHOWN IN JOINT DETAILS.
 - B. REMOVE CONCRETE AND DISPOSE OF MATERIALS TO LIMITS SHOWN AND REPLACE WITH CONCRETE.
 - C. REMOVE PREFORMED BITUMINOUS JOINT FILLER (IF ANY) TO DEPTH SHOWN OR AS DIRECTED BY THE ENGINEER.
 - D. BLOCKING FOR PROPOSED PREFORMED ELASTOMERIC JOINT SEALER.
 - E. REPLACEMENT OF CORROSION PROTECTED REINFORCING BARS.
 - F. PROPOSED PREFORMED BITUMINOUS JOINT FILLER WHERE REQUIRED.
 - G. DRILL AND FILL HOLES WITH NON-SHRINK GROUT.
 - H. SAWCUTTING THE CURB AND SIDEWALK TO INSTALL THE SEALER.
3. EPOXY BONDING COMPOUND SHALL BE USED BETWEEN NEW AND EXISTING CONCRETE. REFER TO NJDOT SPECIFICATION SECTION 518.
4. PROVIDE AS REQUIRED ARMORED JOINT.

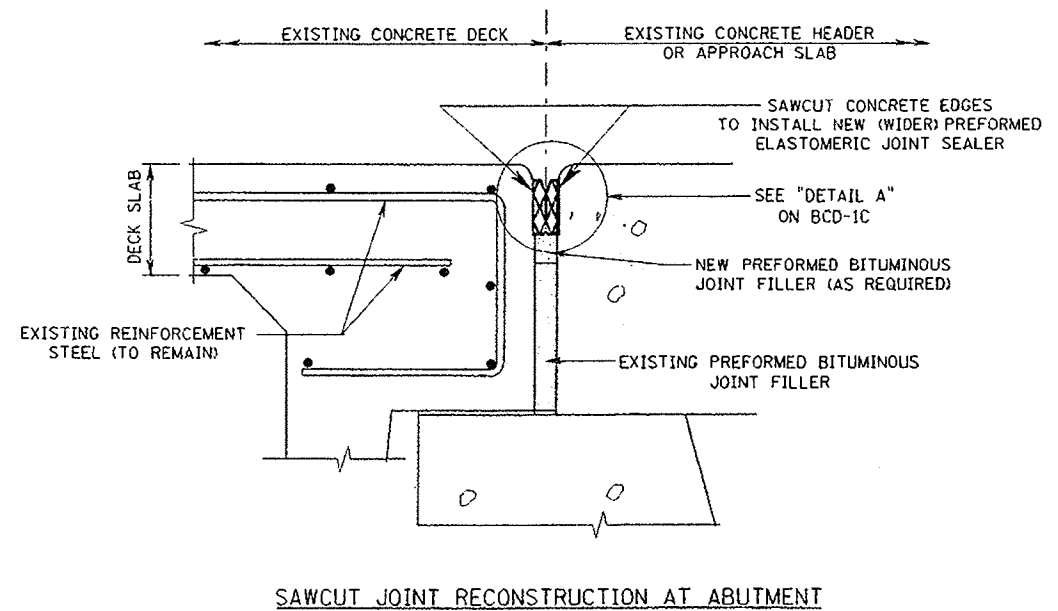

SAWCUT JOINT RECONSTRUCTION AT ABUTMENT

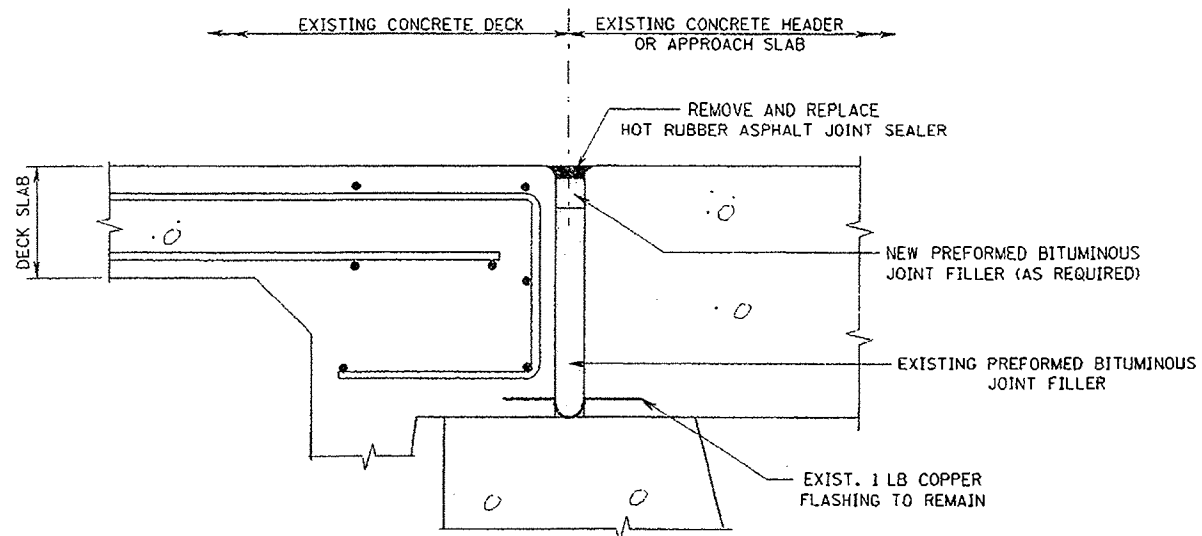

DECK JOINT RE-SEAL AT ABUTMENT

BCD-1D

NEW JERSEY DEPARTMENT OF TRANSPORTATION
 BRIDGE CONSTRUCTION DETAILS
 BRIDGE DECK REHABILITATION
 DECK JOINT REPAIR
 (SHEET 2 OF 2)

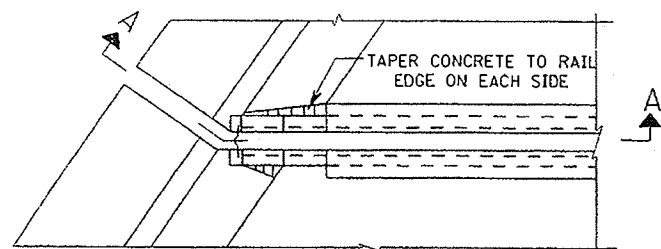

PARAPET PLAN FOR SKEWS > 30°

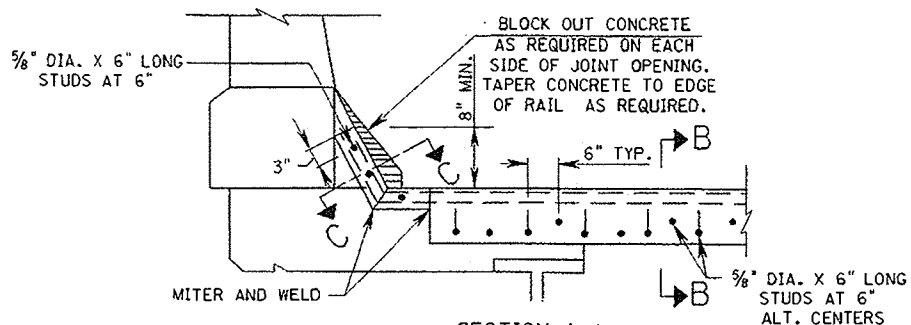

SECTION A-A

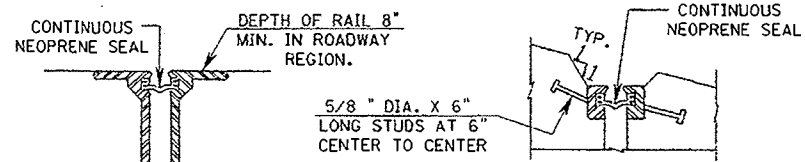

SECTION B-B

SECTION C-C

NOTES:

1. THE DETAIL ABOVE IS INTENDED AS A GENERAL GUIDE TO A TYPICAL GLANDULAR TYPE STRIP SEAL SYSTEM. VARIATIONS TO THE GLAND SHAPE, RAIL SHAPE, STUD ARRANGEMENT, AND SUPPORT DETAILS SHALL BE SUBMITTED ACCORDING TO THE NJDOT WORKING DRAWING SPECIFICATIONS.
2. DETAILS FOR MEDIAN BARRIER ARE SIMILAR.
3. THE JOINT OPENING IN THE PARAPET SHALL BE PARALLEL TO THE SKEW FOR SKEWS LESS THAN 30 DEGREES.

BCD-2.1

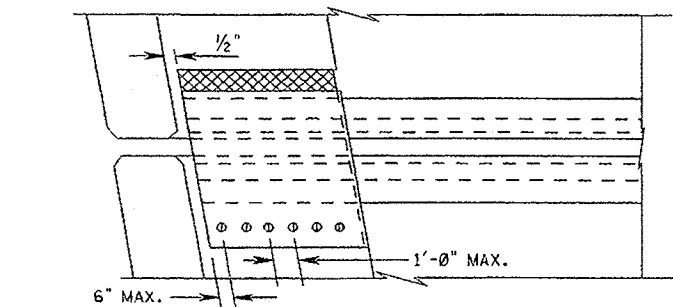

SIDEWALK PLAN
Skew < 15°

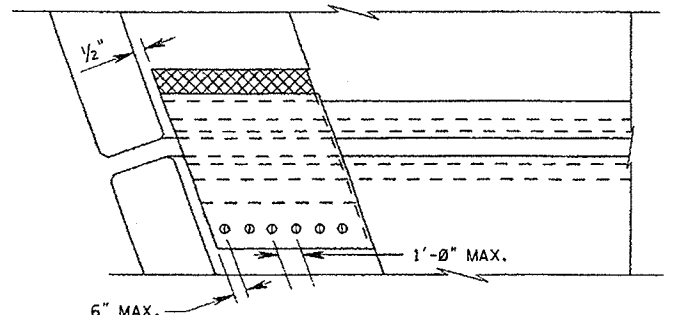

SIDEWALK PLAN
Skew > 15°

BCD-2.4

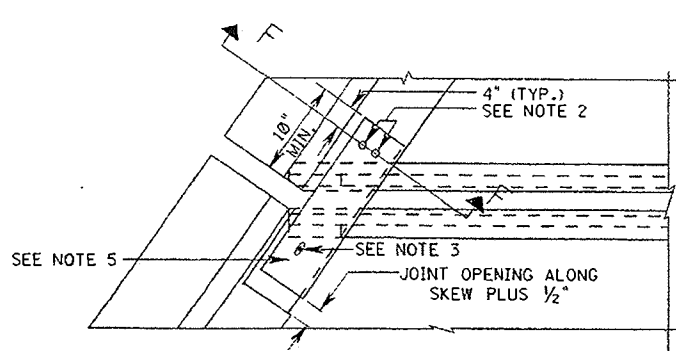

PARAPET PLAN

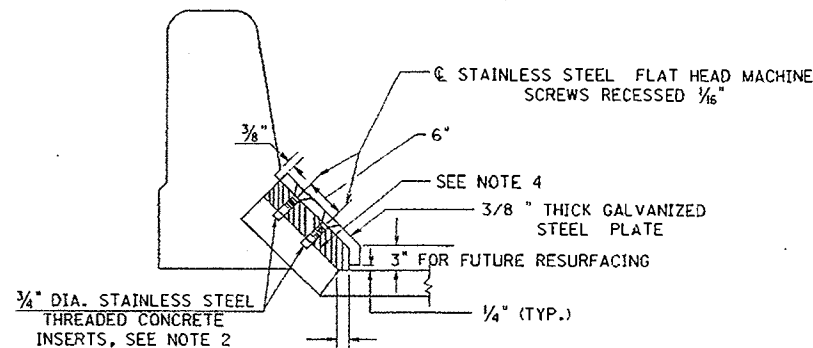

SECTION F-F

NOTES:

1. THE DETAIL ABOVE IS INTENDED AS A GENERAL GUIDE TO A TYPICAL GLANDULAR TYPE STRIP SEAL SYSTEM. VARIATIONS TO THE GLAND SHAPE, RAIL SHAPE, STUD ARRANGEMENT, AND SUPPORT DETAILS SHALL BE SUBMITTED ACCORDING TO THE NJDOT WORKING DRAWING SPECIFICATIONS.
2. 2 - 3/4" DIA. X 1 1/2" STAINLESS STEEL FLAT HEAD MACHINE SCREWS WITH 2 - 3/4" DIA. CAST-IN-PLACE STAINLESS STEEL THREADED CONCRETE INSERTS. RECESS 1/16" BELOW PLATE SURFACE.
3. 1" X 5" SLOTTED HOLE FOR SKEWS TO 45°; 1" X 6" SLOTTED HOLE FOR SKEWS OVER 45°. HOLE SLOTTED PARALLEL TO DIRECTION OF MOVEMENT WITH 1 - 3/4" X 1 1/2" STAINLESS STEEL FLAT HEAD MACHINE SCREW RECESSED 1/16" BELOW PLATE SURFACE IN 3/4" CAST-IN-PLACE STAINLESS STEEL THREADED CONCRETE INSERT. DO NOT OVER TIGHTEN MACHINE SCREWS.
4. BLOCK OUT CONCRETE AS REQUIRED ABOVE JOINT OPENING.
5. 3/8" THICK BY 1'-2" WIDE X (2'-0" LONG FOR SKEWS TO 45° AND 3'-0" LONG FOR SKEWS LARGER THAN 45°) GRADE 36 GALVANIZED STEEL PLATE BENT WITH HOLES AS SHOWN.

BCD-2.2

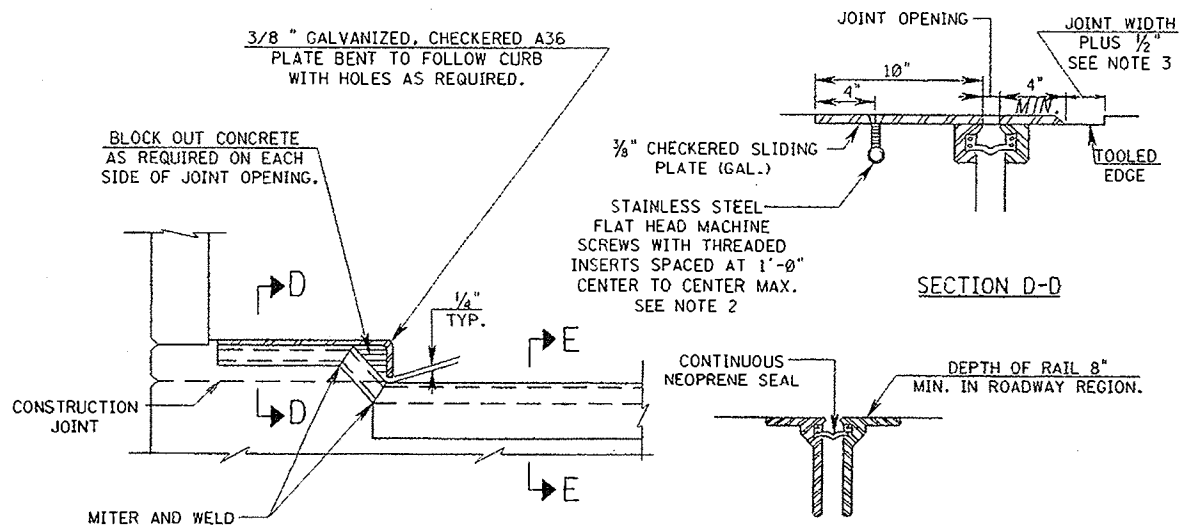

SIDEWALK ELEVATION

SECTION D-D

BCD-2.5

NOTES:

1. THE DETAIL SHOWN HERE IS INTENDED AS A GENERAL GUIDE TO A TYPICAL GLANDULAR TYPE STRIP SEAL SYSTEM. VARIATIONS TO THE GLAND SHAPE, RAIL SHAPE, STUD ARRANGEMENT, AND SUPPORT DETAILS SHALL BE SUBMITTED ACCORDING TO THE NJDOT WORKING DRAWING SPECIFICATIONS.
2. 3/4" DIA. X 1 1/2" STAINLESS STEEL FLAT HEAD MACHINE SCREWS WITH 3/4" DIA. CAST-IN-PLACE STAINLESS STEEL THREADED CONCRETE INSERTS. RECESS 1/16" BELOW PLATE SURFACE.
3. UPON COMPLETION, FILL JOINT OPENING WITH A LOW MODULUS SILICON RUBBER JOINT SEALER CONFORMING TO ASTM D 5893 WITH A MIN. ULTIMATE ELONGATION OF 1200 PERCENT. THE JOINT FILLER SHALL MATCH THE COLOR OF THE CONCRETE.

BCD-2

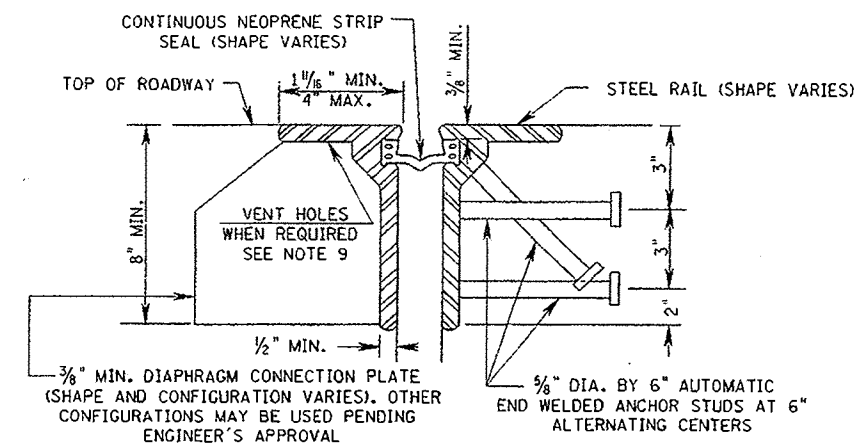

TYPICAL SECTION

NOTES:

1. THE DETAIL ABOVE IS INTENDED AS A GENERAL GUIDE TO A TYPICAL GLANDULAR TYPE STRIP SEAL SYSTEM. VARIATIONS TO THE GLAND SHAPE, RAIL SHAPE, STUD ARRANGEMENT, AND SUPPORT DETAILS SHALL BE SUBMITTED ACCORDING TO THE NJDOT WORKING DRAWING SPECIFICATIONS.
2. STEEL RAILS SHALL CONFORM TO AASHTO M270, GRADE 36.
3. AUTOMATIC END WELDED STUDS SHALL CONFORM TO AASHTO M169 (ASTM A108), GRADES 1015, 1018 OR 1020.
4. PLATES, SHAPES AND OTHER STRUCTURAL STEEL MATERIAL USED IN THE DECK JOINT SYSTEM WITH THE STEEL RAILS SHALL CONFORM TO AASHTO M183.
5. ALL STRUCTURAL STEEL SHALL BE HOT DIP GALVANIZED AFTER FABRICATION PER AASHTO M111.
6. FIELD SPLICES FOR STEEL RAILS SHALL BE PLACED AT GRADE BREAKS AND LONGITUDINAL BREAKS IN THE DECK.
7. NEOPRENE STRIP SEAL SHALL BE INSTALLED IN A CONTINUOUS LENGTH OVER THE ENTIRE WIDTH OF THE SUPERSTRUCTURE WITH NO FIELD SPLICES PERMITTED. AN APPROVED LUBRICANT/ADHESIVE FOR THE INSTALLATION AND PERMANENT BONDING TO THE STEEL RAIL SHALL BE PLACED PRIOR TO THE STRIP SEAL INSTALLATION.
8. WHERE A LONGITUDINAL AND TRANSVERSE JOINT INTERSECT, THE JOINT SUBJECTED TO THE GREATER MOVEMENT SHALL BE MADE CONTINUOUS AND THE OTHER SEAL SHALL BUTT UP AGAINST IT. ALL JOINT INTERSECTIONS SHALL BE SUBJECT TO APPROVAL BY THE ENGINEER.
9. 5/8" DIA. VENT HOLES SPACED BETWEEN STUDS AT 1'-0" CENTER TO CENTER MAX. ARE REQUIRED WHEN TOP OF STEEL RAIL IS WIDER THAN 3".

BCD-2.3

NEW JERSEY DEPARTMENT OF TRANSPORTATION

BRIDGE CONSTRUCTION DETAILS
STRIP SEAL DECK JOINTS

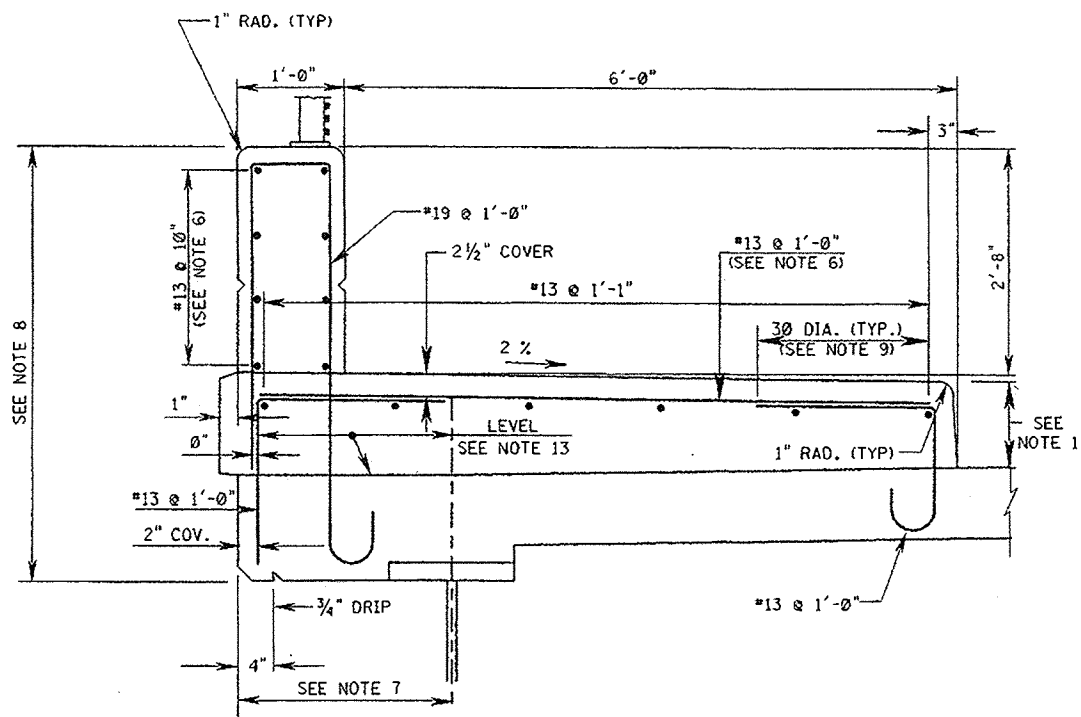

2'-8" HIGH PARAPET WITH SIDEWALK

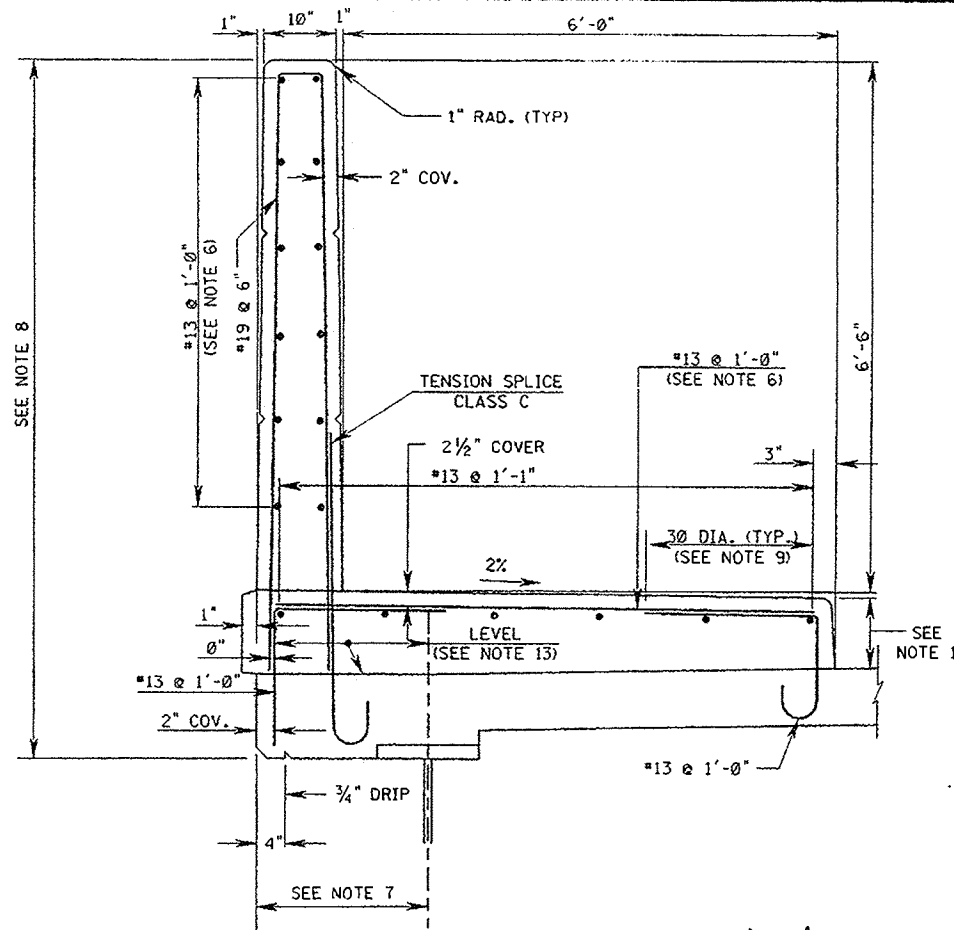

6'-6" HIGH PARAPET WITH SIDEWALK OVER ELECTRIFIED RAILROAD

NOTES:

1. CURB HEIGHT TO MATCH ROADWAY APPROACH CURB.
2. 3/16" OPEN DEFLECTION JOINT SHALL BE PROVIDED IN PARAPETS AT INTERVALS NOT EXCEEDING 20'-0" AND CONTRACTION JOINTS SHALL BE PROVIDED AT THE MIDPOINT BETWEEN THE OPEN JOINTS.
3. THE 3/16" OPEN JOINT SHALL STOP AT THE LINE INDICATED AND A CONTRACTION JOINT SHALL BE PROVIDED BELOW THAT LINE.
4. CONTRACTION JOINTS SHALL BE PROVIDED IN SIDEWALKS AT LOCATIONS OF 3/16" OPEN PARAPET DEFLECTION JOINTS.
5. FULL DEPTH JOINTS SHALL BE PROVIDED AT LOCATION OF TRANSVERSE DECK JOINTS. THE FULL DEPTH JOINT OPENING WIDTH SHALL EQUAL THE TRANSVERSE DECK JOINT OPENING WIDTH.
6. ALL REINFORCEMENT BARS IN PARAPET AND SIDEWALK SHALL BE CORROSION PROTECTED.
7. PREFERRED MAXIMUM OVERHANG 2'-6". PERMANENT METAL STAY-IN-PLACE FORMS NOT PERMITTED IN THIS AREA.
8. FASCIA RUSTICATION AND CONFIGURATION AS PER NJDOT SPECIFICATIONS.
9. AS AN OPTION, THE CONTRACTOR MAY ELIMINATE SPLICES AT EACH END OF THE TOP TRANSVERSE REINFORCEMENT IN SIDEWALKS BY PROVIDING A SINGLE BAR OF THE SAME CONFIGURATION WITH HOOKS AT EACH END, EMBEDDED IN THE DECK SLAB.
10. IF CONDUITS ARE USED WITHIN THE PARAPET, PROVIDE A SLEEVE OF SUFFICIENT LENGTH TO ACCOMMODATE MAXIMUM EXPANSION AND CONTRACTION OF THE EXPANSION JOINT.
11. IN CONSIDERING THE HEIGHT OF THE PARAPET AND RAILING COMBINATION, THE MINIMUM HEIGHT SHALL BE 4'-6" FOR BICYCLE TRAFFIC AND 3'-6" FOR PEDESTRIAN TRAFFIC.
12. FOR ADDITIONAL REINFORCEMENT THAT IS REQUIRED IN THE VICINITY OF PARAPET JOINTS TO PREVENT CONCRETE CRACKING IN THE OVERHANG PORTIONS OF THE DECK SLAB, SEE "DETAIL 1."
13. THE BRIDGE DECK PORTION UNDER THE PARAPET SHALL BE POURED LEVEL.
14. ALL REINFORCEMENT BARS ARE IN METRIC UNITS.

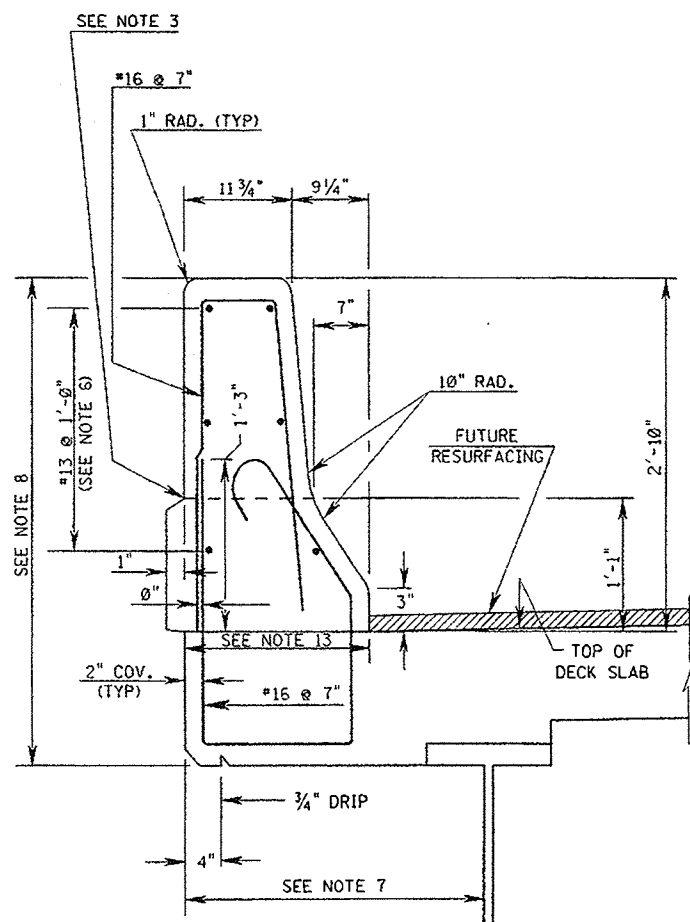

2'-10" HIGH PARAPET WITH BARRIER CURB

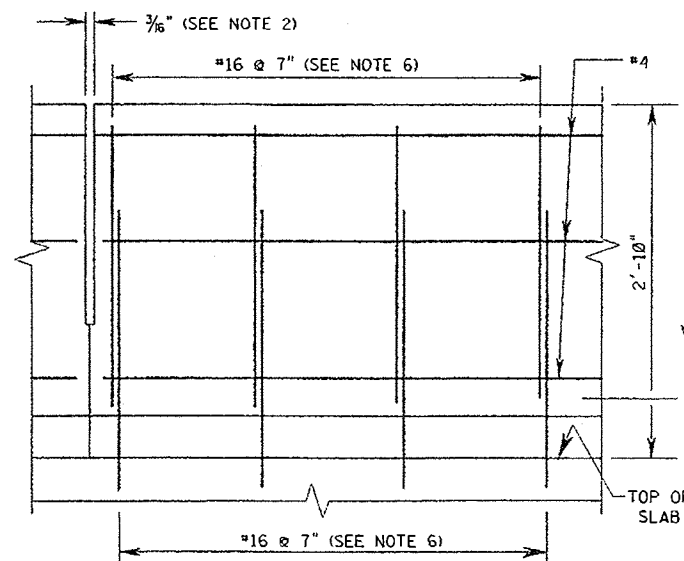

ELEVATION

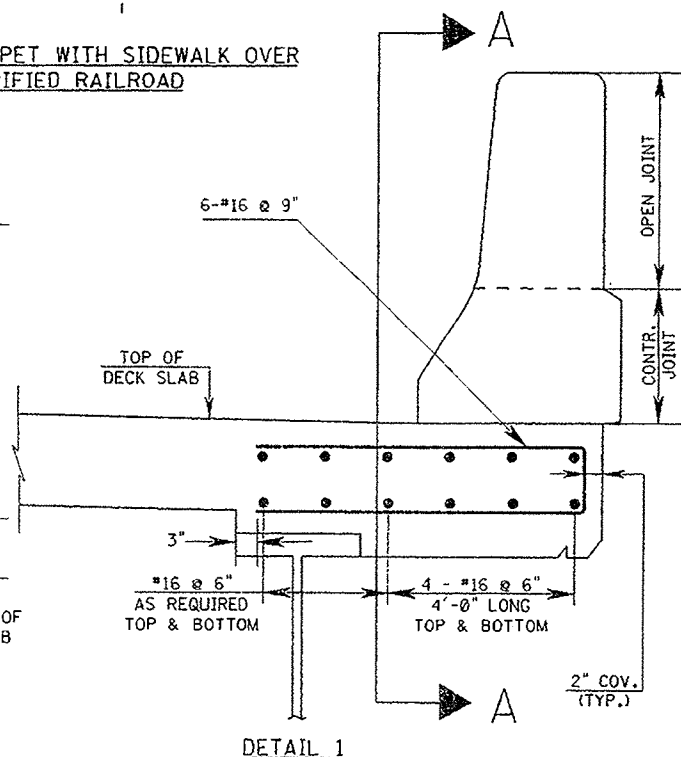

DETAIL 1

DECK REINFORCEMENT AT BARRIER/PARAPET JOINTS

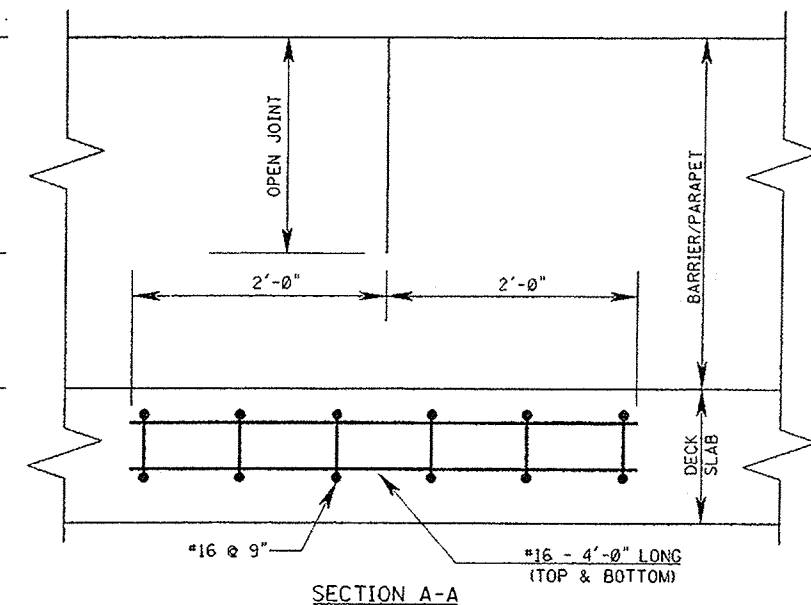

SECTION A-A

BCD-3

NEW JERSEY DEPARTMENT OF TRANSPORTATION

BRIDGE CONSTRUCTION DETAILS

2'-8", 2'-10", AND 6'-6" PARAPETS

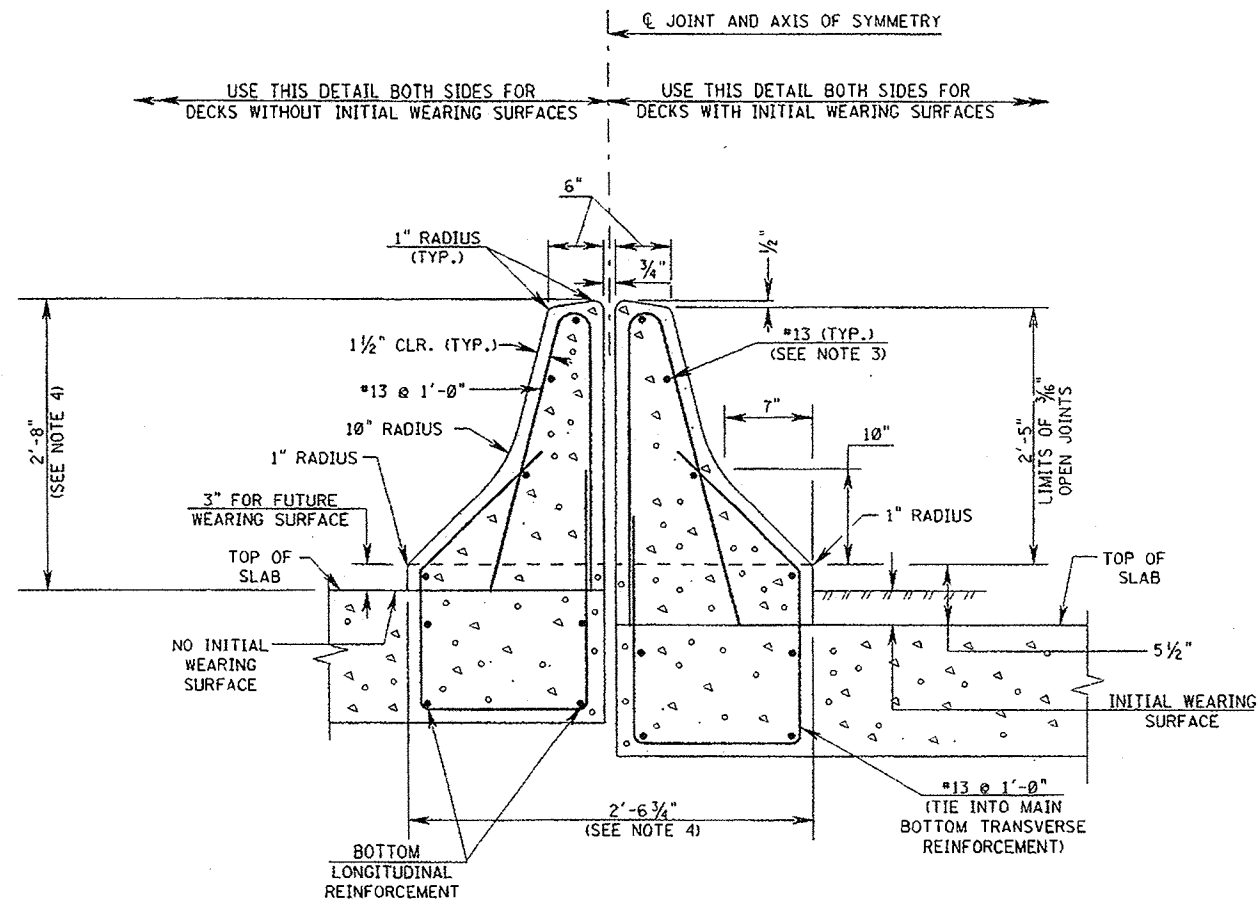

TYPICAL SECTION

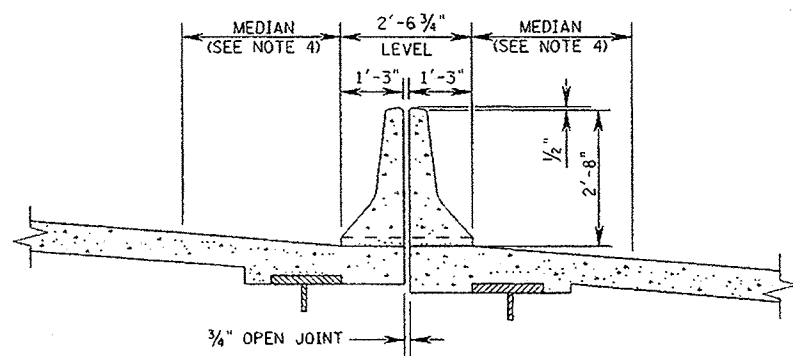

CROSS SECTION

2'-8" HIGH SPLIT MEDIAN BARRIER ON BRIDGE

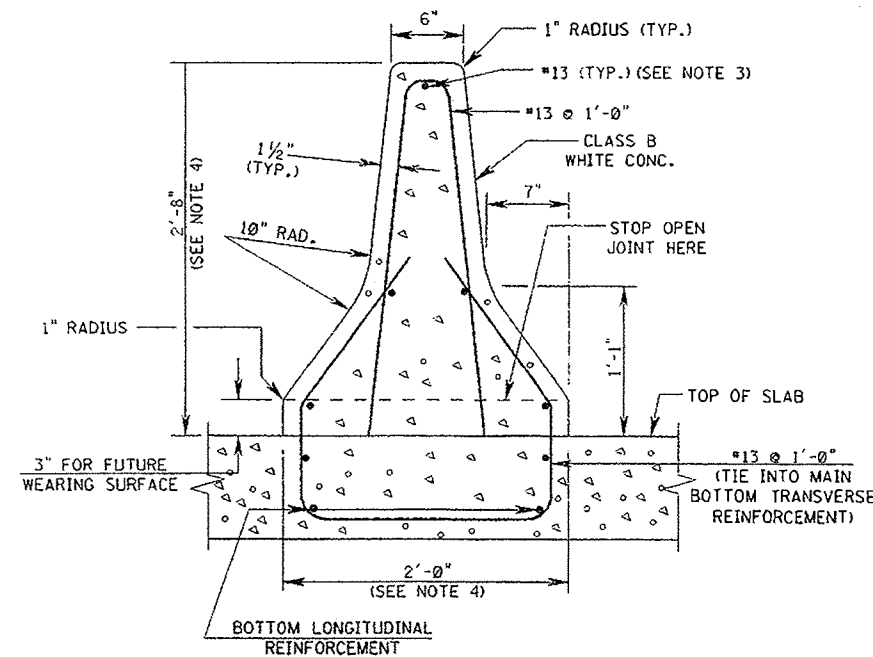

SECTION A-A

2'-8" HIGH MEDIAN BARRIER ON BRIDGE

NOTES:

1. 3/16" OPEN DEFLECTION JOINT SHALL BE PROVIDED AT INTERVALS NOT EXCEEDING 15'-0". THERE SHALL BE NO CONTRACTION JOINTS BETWEEN THE OPEN JOINTS AND NO CONTRACTION JOINTS LOCATED BELOW THE OPEN DEFLECTION JOINTS.
2. FULL DEPTH JOINTS SHALL BE PROVIDED AT LOCATION OF TRANSVERSE DECK JOINTS. THE FULL DEPTH JOINT OPENING WIDTH SHALL EQUAL THE TRANSVERSE DECK JOINT OPENING WIDTH.
3. ALL REINFORCEMENT BARS IN MEDIAN BARRIER ARE IN METRIC UNITS AND SHALL BE CORROSION PROTECTED.
4. WIDTH AND HEIGHT TO BE DETERMINED BY ROADWAY APPROACH BARRIER. REINFORCEMENT MUST BE ADJUSTED ACCORDINGLY.
5. IF CONDUITS ARE USED WITHIN THE MEDIAN BARRIER, PROVIDE A SLEEVE OF SUFFICIENT LENGTH TO ACCOMMODATE MAXIMUM EXPANSION OF THE EXPANSION JOINT. (REFER TO STANDARD ELECTRICAL DETAILS FOR CONDUIT EXPANSION FITTINGS.)

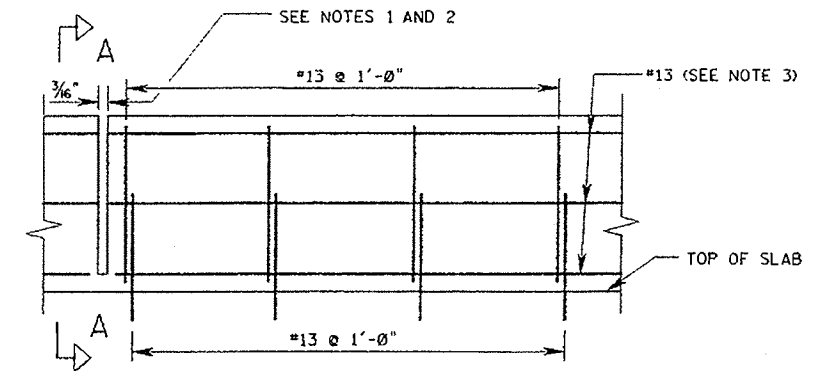

ELEVATION

BCD-4

NEW JERSEY DEPARTMENT OF TRANSPORTATION

BRIDGE CONSTRUCTION DETAILS

BRIDGE MEDIAN BARRIER

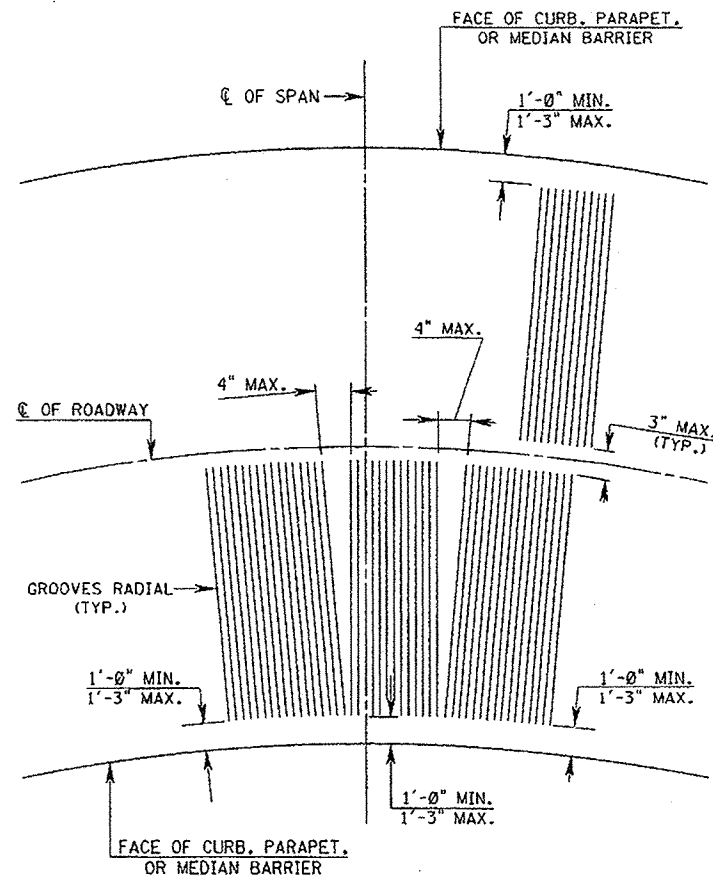

SAWCUT GROOVING FOR BRIDGE DECKS ON CURVED ALIGNMENT

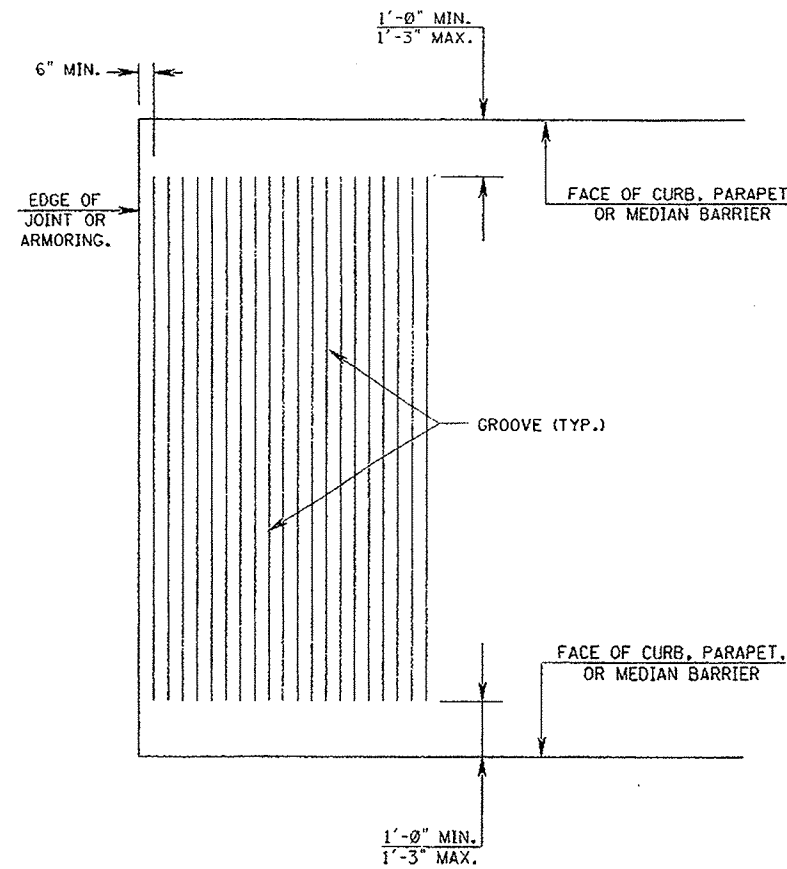

SAWCUT GROOVING FOR BRIDGE DECKS

NOTES:

SAWCUT GROOVES SHALL BE RECTANGULAR IN CROSS SECTION WITH THE FOLLOWING DIMENSIONS:

WIDTH 0.10" TO 0.15"
 DEPTH 0.25" TO 0.375"

GROOVES SHALL BE SPACED AT $1\frac{1}{2} \pm \frac{1}{16}$ " CENTER TO CENTER.

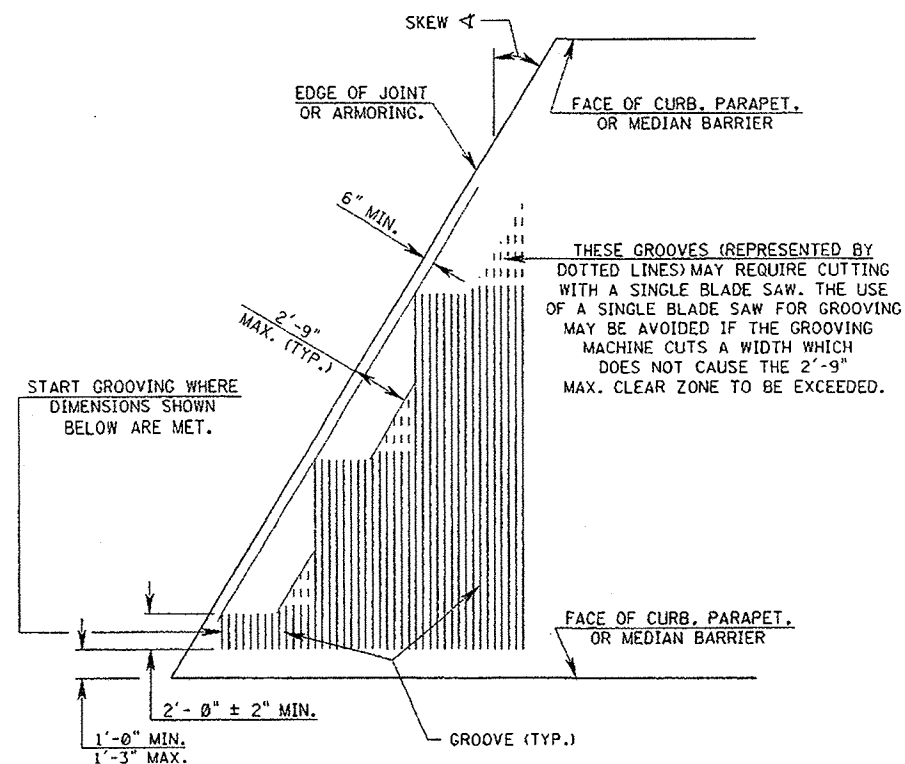

SAWCUT GROOVING FOR SKEWED BRIDGE DECKS

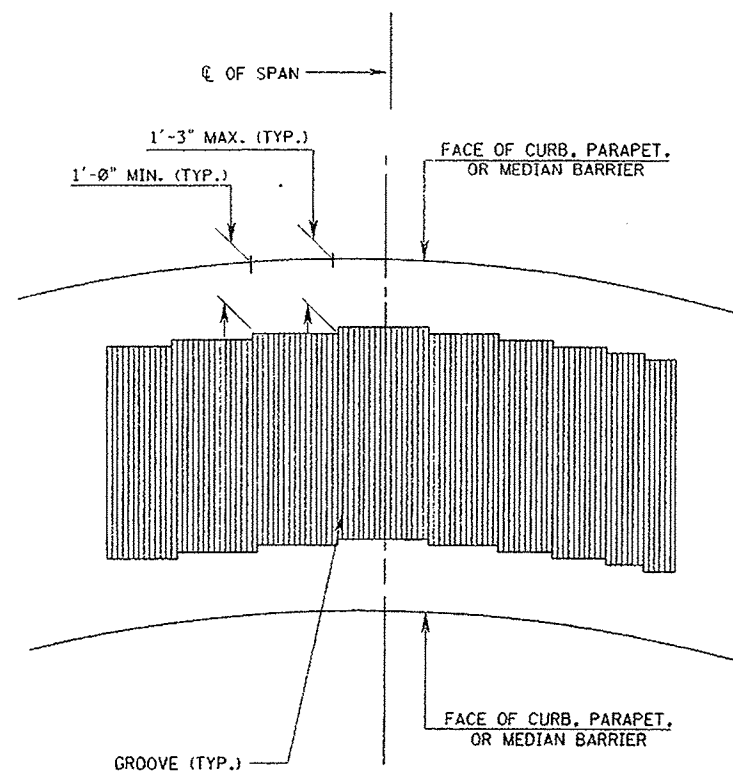

SAWCUT GROOVING FOR BRIDGE DECKS ON TIGHT CURVED ALIGNMENT

BCD-5

NEW JERSEY DEPARTMENT OF TRANSPORTATION

BRIDGE CONSTRUCTION DETAILS

SAWCUT GROOVING FOR BRIDGE DECKS

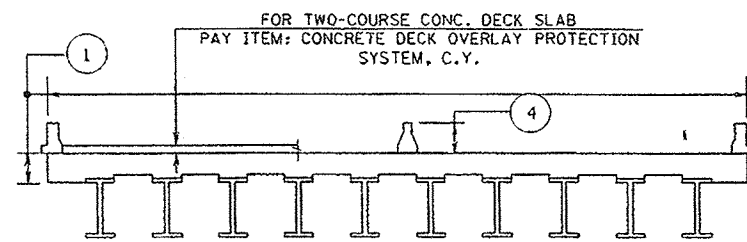

TYPICAL SECTION - BRIDGE DECK

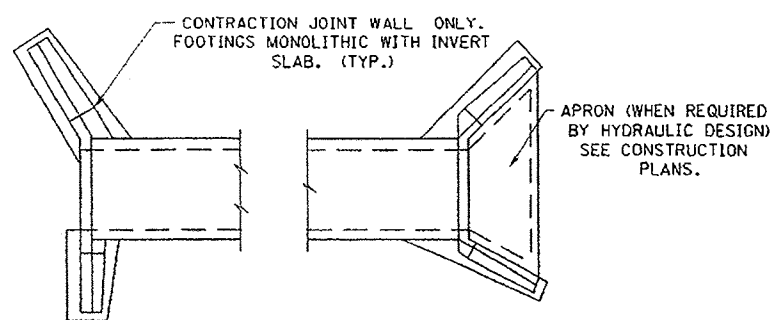

TYPICAL PLAN - CULVERT AND HEADWALLS

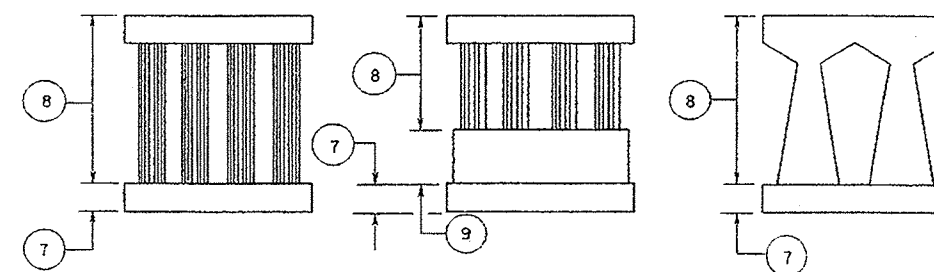

TYPICAL RIGID FRAME TYPE PIER - ELEVATIONS

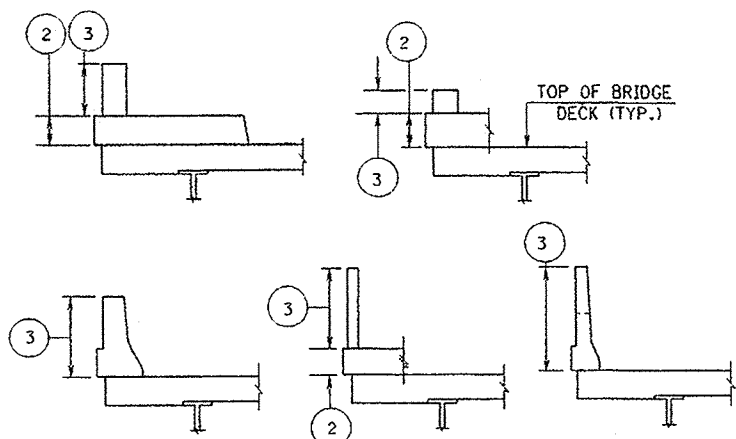

TYPICAL SECTION - BRIDGE PARAPETS

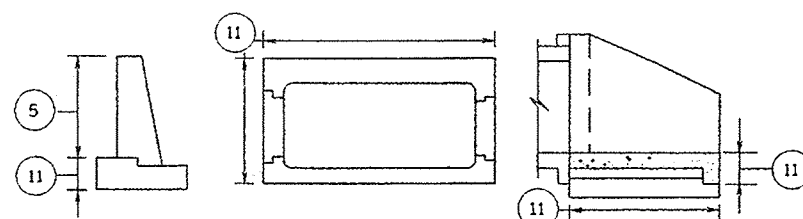

TYPICAL SECTION - CULVERT AND HEADWALLS

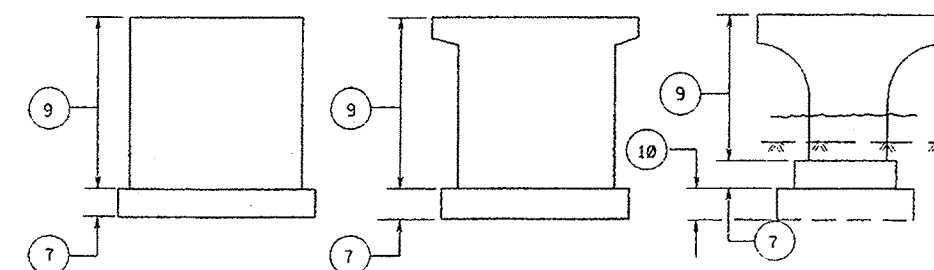

TYPICAL SOLID SHAFT TYPE PIER - ELEVATIONS

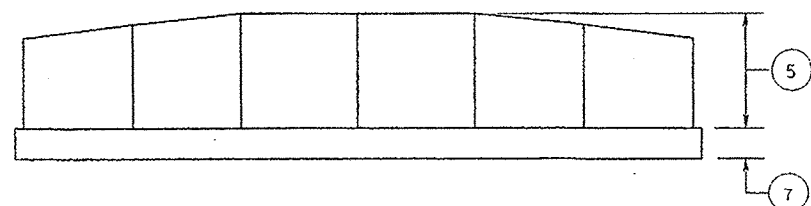

TYPICAL ELEVATION - RETAINING WALL

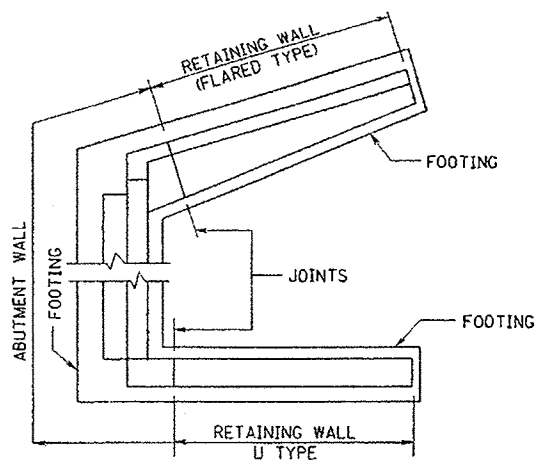

TYPICAL PLAN - ABUTMENTS

ITEM	CONCRETE CLASS	PAY ITEM	UNIT
①	A	CONCRETE IN SUPERSTRUCTURE, DECK SLAB	C.Y.
②	A	CONCRETE IN SUPERSTRUCTURE, SIDEWALKS	C.Y.
③	A	CONCRETE IN SUPERSTRUCTURE, PARAPETS	L.F.
④	B	---" x ---" WHITE CONCRETE BARRIER CURB, BRIDGE	L.F.
⑤	B	CONCRETE IN STRUCTURES, RETAINING WALLS	C.Y.
⑥	B	CONCRETE IN SUBSTRUCTURES, ABUTMENT WALLS	C.Y.
⑦	B	CONCRETE IN STRUCTURES, FOOTINGS	C.Y.
⑧	A	CONCRETE IN SUBSTRUCTURES, PIER COLUMNS AND CAPS	C.Y.
⑨	B	CONCRETE IN SUBSTRUCTURES, PIER SHAFTS	C.Y.
⑩	B	CONCRETE SEAL IN COFFERDAMS	C.Y.
⑪	A	CONCRETE IN STRUCTURES, CULVERTS	C.Y.

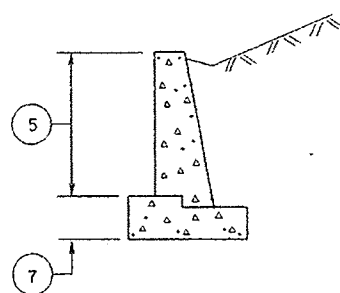

TYPICAL SECTION - RETAINING WALL

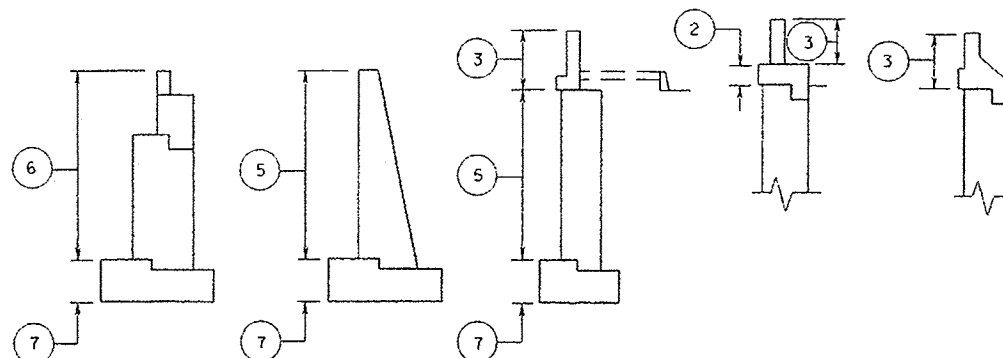

TYPICAL SECTION - VARIOUS WALLS AND PARAPETS

BCD-6

NEW JERSEY DEPARTMENT OF TRANSPORTATION

BRIDGE CONSTRUCTION DETAILS
CONCRETE CLASSES AND
PAY ITEMS

125
129

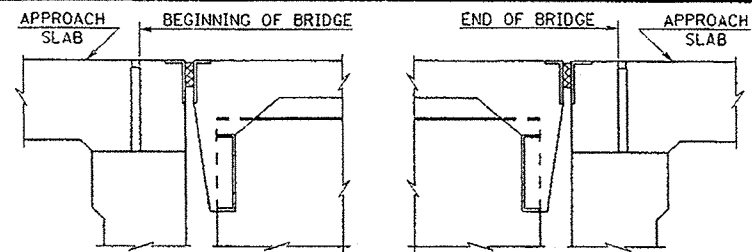

STEEL STRINGERS

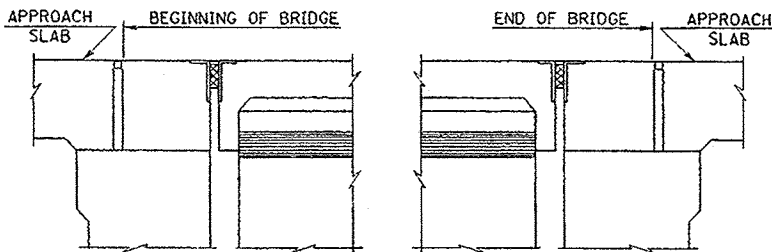

P.C.I. BEAMS

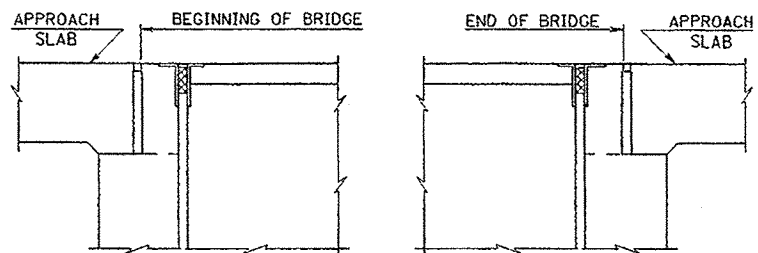

P.C. SLAB AND BOX BEAMS

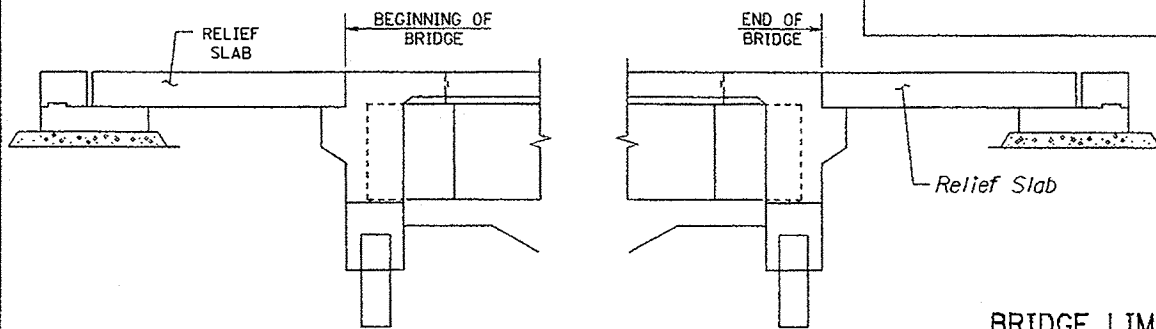

INTEGRAL ABUTMENT BRIDGE

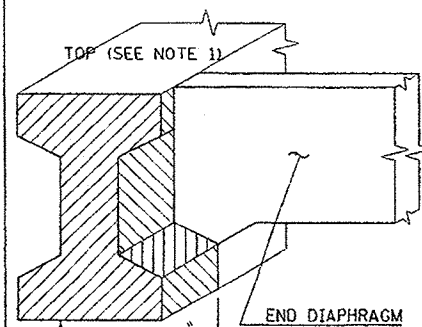

INTERIOR FACE OF BEAMS

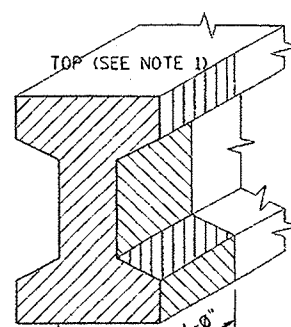

EXTERIOR FACE OF FASCIA BEAMS

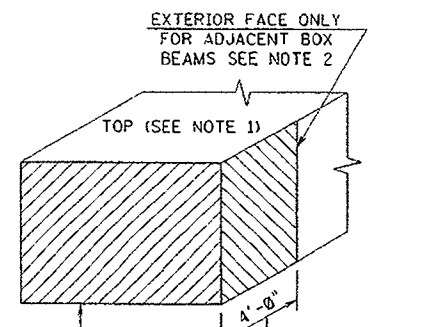

EXTERIOR FACE OF FASCIA BOX BEAMS

NOTES:

1. NO SEALER SHALL BE APPLIED TO THE TOP SURFACE OF ANY BEAM.
2. SEALER SHALL BE APPLIED TO THE ENDS, BOTTOMS AND EXTERIOR SIDES OF FASCIA BEAMS FOR ALL ADJACENT BOX BEAMS. SIDES OF INTERIOR BOX BEAMS SHALL NOT BE COATED. SEALER SHALL BE APPLIED TO THE ENDS, SIDES AND BOTTOMS OF ALL I-BEAMS.
3. THE SEAL COAT SHALL ONLY BE APPLIED TO BEAM ENDS UNDER DECK JOINTS.
4. VOIDED SLAB BEAMS SIMILAR TO BOX BEAM DETAILS FOR EPOXY WATERPROOFING SEAL COAT LIMITS.
5. EPOXY WATERPROOFING SEAL COAT SHALL BE OMITTED FROM THE BEARING CONTACT AREAS FOR VARIOUS TYPES OF BEARINGS, CHECK BEARING MANUFACTURER'S RECOMMENDATIONS.

PRESTRESSED CONCRETE I-BEAMS, VOIDED SLAB AND BOX BEAMS
EPOXY WATERPROOFING SEAL COAT LIMITS

BCD-7.2

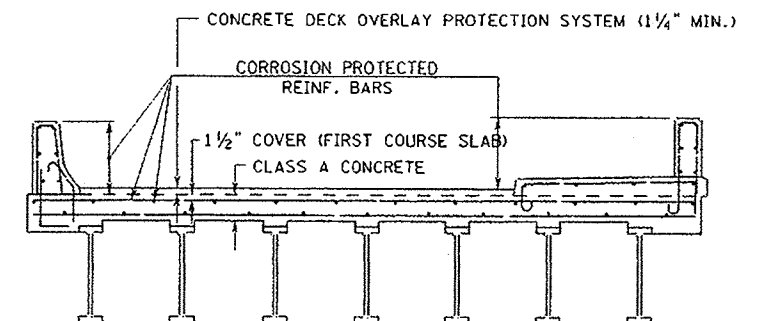

TWO-COURSE CONCRETE DECK SLAB

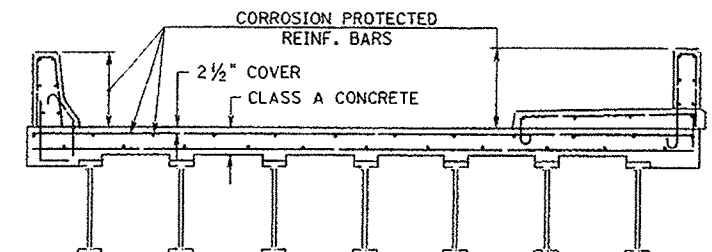

ONE-COURSE CONCRETE DECK SLAB

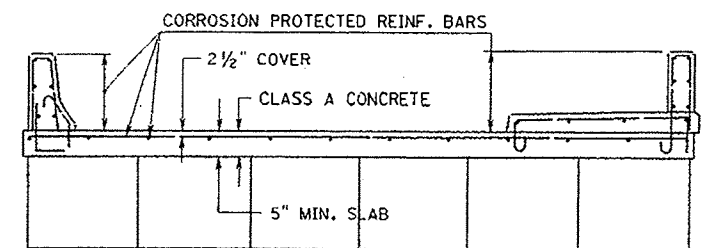

CONCRETE OVERLAY SLAB ON PRESTRESSED CONCRETE VOIDED SLAB OR BOX BEAMS

NOTE:

ALL REINFORCEMENT BARS IN PARAPETS AND SIDEWALKS SHALL BE EPOXY COATED.

BRIDGE DECK CONSTRUCTION PROTECTIVE SYSTEMS (NEW BRIDGE DECKS)

BCD-7.3

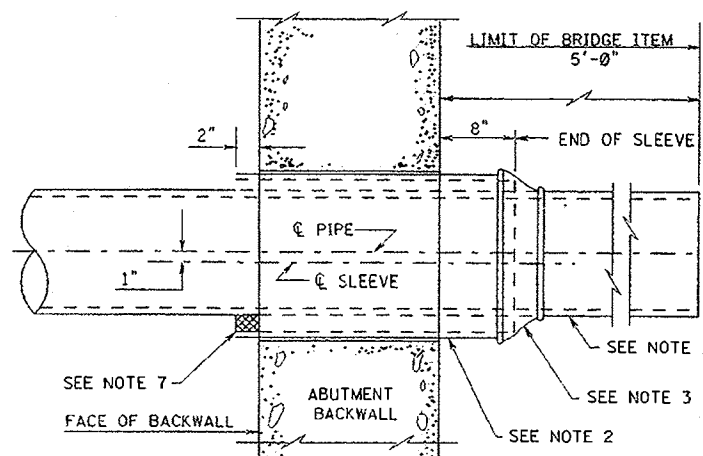

SLEEVE DETAIL FOR STEEL GAS MAINS

NOTES:

1. GAS MAIN FURNISHED AND INSTALLED BY UTILITY COMPANY.
2. GALVANIZED SLEEVE FURNISHED AND INSTALLED BY CONTRACTOR.
3. CASING SEAL FURNISHED AND INSTALLED BY UTILITY COMPANY.
4. ENDS OF SLEEVE SHALL BE CUT SQUARE AND FREE FROM BURRS.
5. GRADE (SLOPE) OF SLEEVE SHALL BE SAME AS GRADE OF GAS MAIN.
6. ϕ OF GAS MAIN SHALL BE INSTALLED 1" HIGHER THAN ϕ OF SLEEVE.
7. BLOCK INSTALLED TO INITIALLY POSITION THE PIPE AND SHALL BE REMOVED AFTER GAS MAIN APPROACH ROAD HAS BEEN CONNECTED AND BACKFILLED AND COMPACTED FOR BOTTOM HALF OF THE PIPE.
8. PIPE AND SLEEVE SHALL BE TEMPORARILY PLUGGED.
9. THE OPENING BETWEEN THE PIPE AND THE SLEEVE SHALL BE PACKED WITH HEMP, JUTE OR SIMILAR MATERIAL TO PREVENT LEAKAGE THROUGH THE BACKWALL.

BCD-7

NEW JERSEY DEPARTMENT OF TRANSPORTATION

BRIDGE CONSTRUCTION DETAILS
MISCELLANEOUS
BRIDGE ITEMS

126
129

BCD-7.5

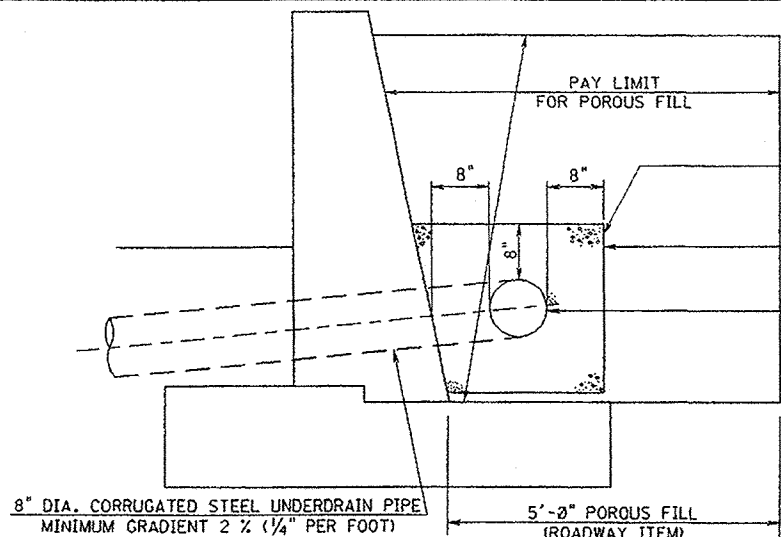

DRAINAGE BACK OF WALL

NOTE:

1. DRAINAGE FOR ABUTMENT WALL STEMS ARE SIMILAR.
2. THE COST OF GEOTEXTILE AND STONE POCKET SHALL BE INCLUDED IN THE PAYMENT FOR 8" DIA. PERFORATED UNDERDRAIN.

BCD-7.4

BD0005-1 - ORIGINAL SHEET

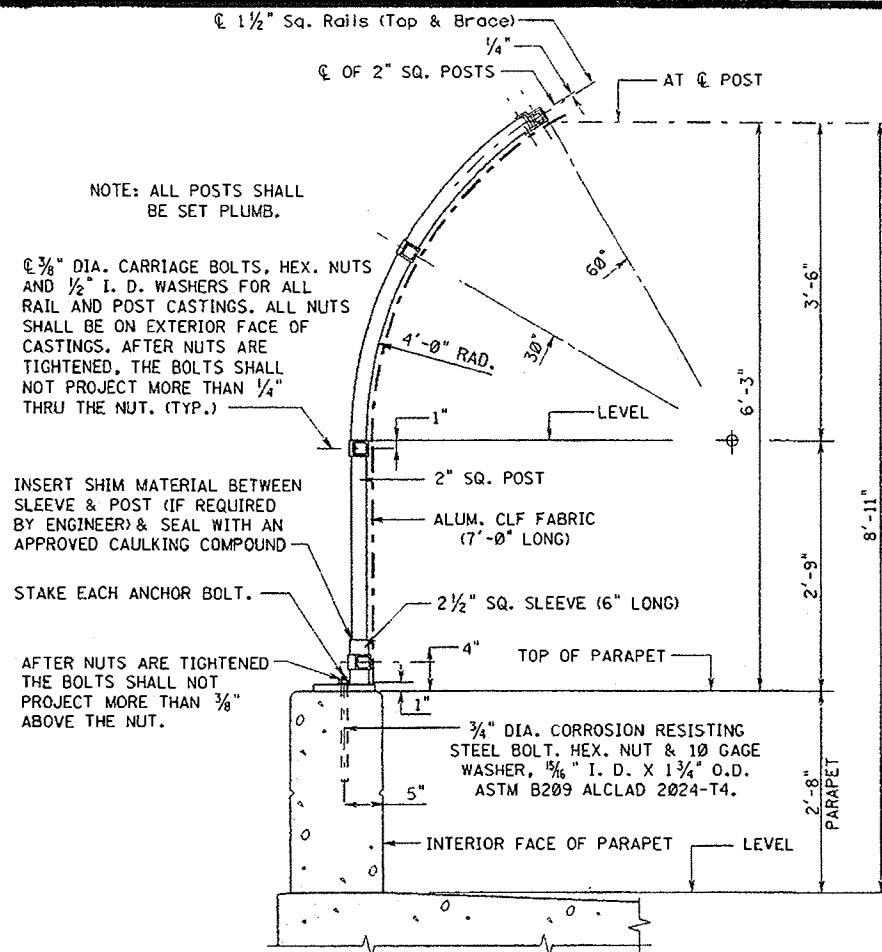

TYPICAL SECTION

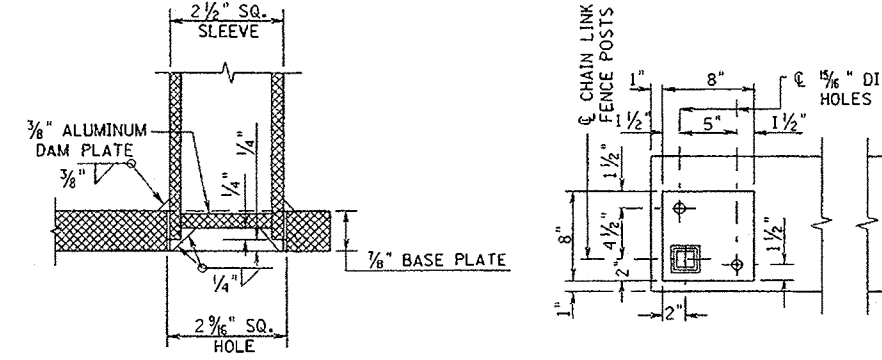

DETAIL OF SLEEVE ATTACHMENT

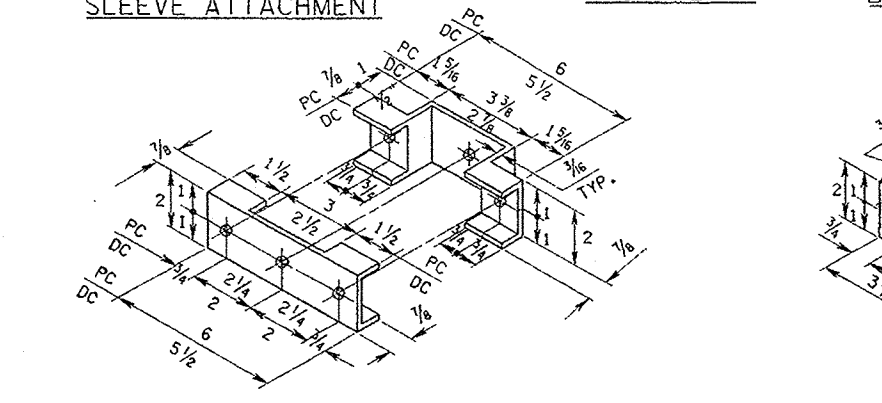

ALL DIMENSIONS ARE IN INCHES

DETAIL PC & DETAIL DC

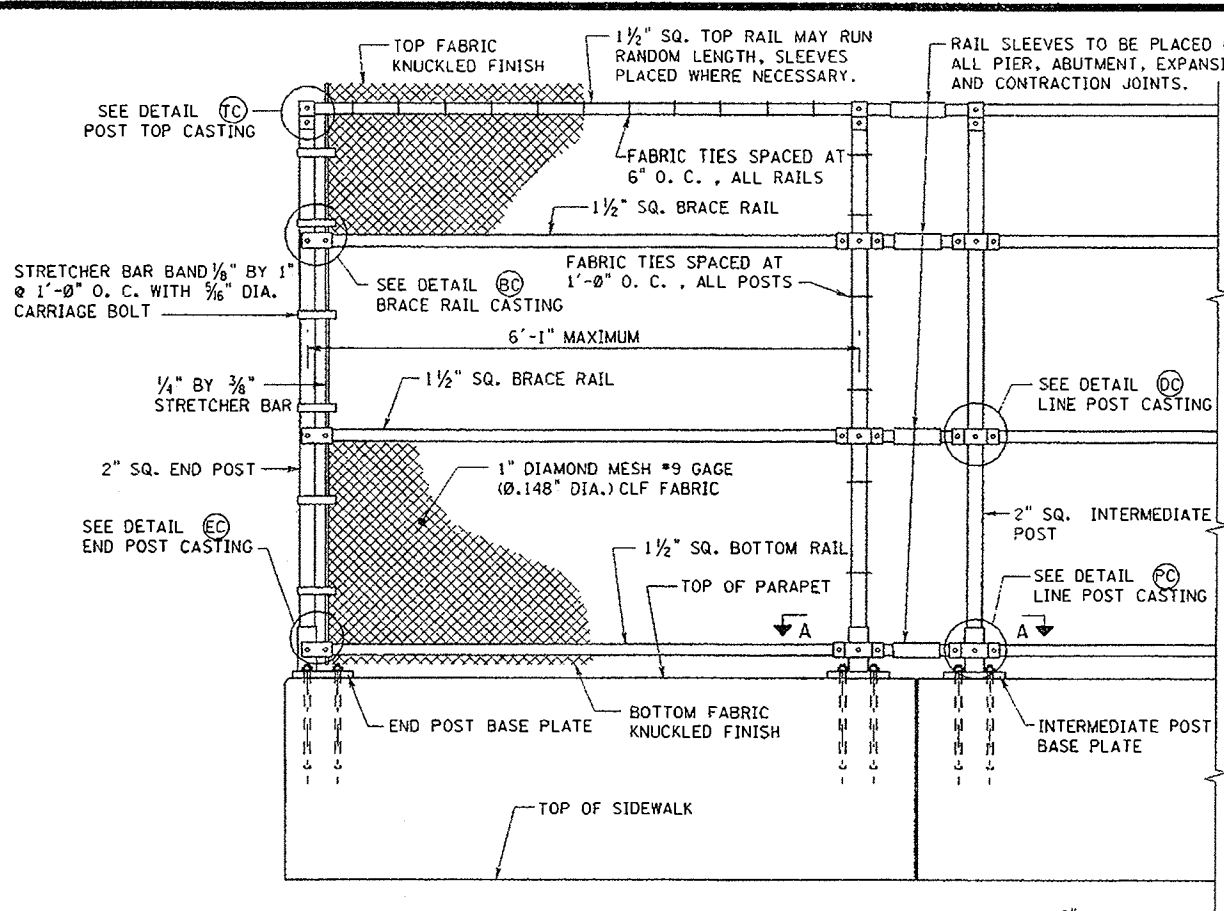

PART EXTERIOR ELEVATION

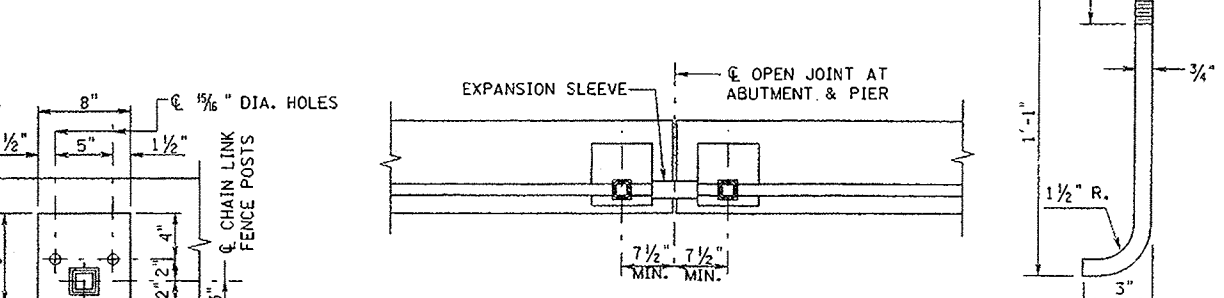

SECTION A-A



ANCHOR BOLT

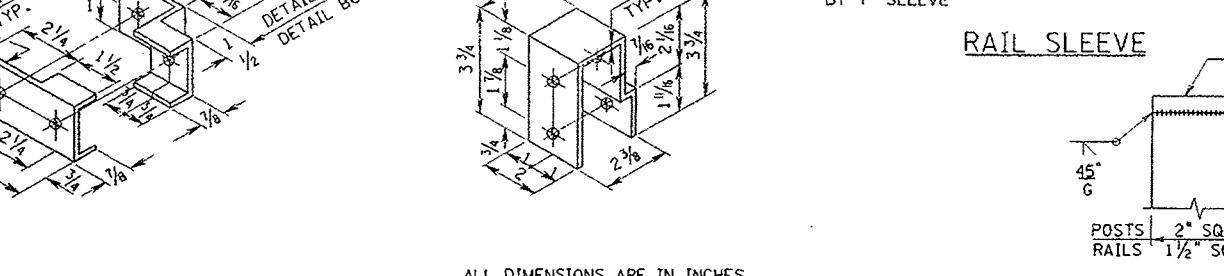

ALL DIMENSIONS ARE IN INCHES

DETAIL TC



ALL DIMENSIONS ARE IN INCHES

DETAIL EC & DETAIL BC

GENERAL NOTES:

DESIGN CRITERIA: "STANDARD SPECIFICATIONS FOR STRUCTURAL SUPPORTS FOR HIGHWAY SIGNS, LUMINAIRES AND TRAFFIC SIGNALS." AASHTO 1994 AND REVISIONS THERETO.

MAXIMUM DESIGN WIND VELOCITY: 80 MPH.

WIND PRESSURE DRAG COEFFICIENT FOR MESH FROM FIG. 1-13, "WIND LOAD ON SCREENS", NAVDOCKS DM-2; DESIGN MANUAL, STRUCTURAL ENGINEERING.

THE COMPONENT PARTS OF THE CHAIN LINK FENCING SHALL CONFORM TO THE MATERIAL REQUIREMENTS OF THE SPECIFICATIONS.

ANCHOR BOLTS SHALL BE ASTM A 276, TYPE 302. ANCHOR BOLTS SHALL BE SET BY THE CONTRACTOR WITH 2" OF CLEAR THREADS, SET CLEAN.

ALUMINUM SURFACES PLACED IN CONTACT WITH CONCRETE SHALL BE GIVEN A HEAVY COAT OF ALUMINUM PIGMENTED ALKALINE RESISTANT BITUMINOUS PAINT EQUAL TO FEDERAL SPECIFICATIONS TT-C-498C.

BASE PLATES FOR ALL CLF SHALL BE AS SHOWN, 3/8" THICK. (ALUMINUM ALLOY 6061-T6)

FILLET WELD MATERIAL SHALL BE FILLER ALLOY ER 5356 OR ER 5556.

POST SLEEVES SHALL BE 2 1/2" SQ., 1/2" WALL THICKNESS, ASTM B 221, AND SHALL BE WELDED TO BASE PLATE. (ALUMINUM ALLOY 6061-T6)

POSTS SHALL BE 2" SQ., 1/4" WALL THICKNESS, ASTM B 221, TO BE SET PLUMB AND SPACED AS SHOWN ON PLANS FOR EACH STRUCTURE. (ALUMINUM ALLOY 6061-T6)

SHIM MATERIAL SHALL BE USED WHERE NECESSARY FOR POST ALIGNMENT, ASTM B 209. (ALUMINUM ALLOY 1100-0)

ALL HORIZONTAL RAILS (TOP, BOTTOM, BRACE) SHALL BE 1 1/2" SQ., 1/8" WALL THICKNESS. (ALUMINUM ALLOY 6061-T6)

DAM PLATES, 3/8" THICK, WELDED TO CLOSE ALL EXPOSED ENDS OF RAIL TUBES AND TOP OF CHAIN LINK FENCE POSTS. (ALUMINUM ALLOY 6061-T6)

BRACE RAILS SHALL BE INSTALLED AT END UNITS WHERE CLF FABRIC IS TENSIONED.

RAILING EXPANSION SLEEVES SHALL BE 2" SQ. X 7" LONG, WITH HOT-DIP GALVANIZED SPRING IN SLEEVE, SPRING NOT TO EXCEED 1 1/2" FULLY COMPRESSED. RAIL ENDS TO BE 3" APART IN SLEEVE AT "V" CRIMP, (ALUMINUM ALLOY 6061-T6) ASTM B 221.

STRETCHER BARS TO BE 1/4" BY 3/8". (ALUMINUM ALLOY 6061-T6)

STRETCHER BAR BANDS TO BE 1/8" X 1" BEVELLED EDGES. (ALUMINUM ALLOY 6063-T6)

FABRIC TIES SHALL BE #9 GAGE (0.148" DIA.), A MINIMUM OF ONE (1) COMPLETE TURN IS REQUIRED AT ENDS OF ALL TIES. (ALUMINUM ALLOY 6061-T6)

CLF FABRIC SHALL BE #9 GAGE (0.148" DIA.) HAVING A 1" DIAMOND MESH, TOP AND BOTTOM SELVAGE TO BE KNUCKLED. FABRIC SHALL BE CONTINUOUS ACROSS ALL JOINTS.

STRETCHER BAR BAND FASTENERS TO BE 5/8" DIA. BY 1/4" CARRIAGE BOLTS. (ALUMINUM ALLOY 2024-T4)

STAKE EACH ANCHOR BOLT AT ONE (1) POINT ONLY.

ALL HOLES IN CASTINGS SHALL BE 7/8" DIA. CASTINGS SHALL BE ALUMINUM TENZALLOY ALLOY ZC81A, CONDITION T5. ALL CASTINGS SHALL BE DESIGNED TO ACCOMMODATE RAILS AT GRADES AS REQUIRED.

AFTER ERECTION, ALL ANCHOR BOLT HOLES & SPACES BETWEEN BASE PLATES & CONCRETE SHALL BE THOROUGHLY CAULKED WITH AN ALUMINUM IMPREGNATED CAULKING COMPOUND CONFORMING TO FEDERAL SPECIFICATIONS TT-C-598B(2).

AFTER ERECTION OF POSTS, DRILL 3/8" DIA. HOLE THROUGH POST SLEEVE AND POST, 1/2" ABOVE BASE PLATE FOR DRAINAGE. LOCATE HOLE PARALLEL TO FENCING.

THE CONTRACTOR SHALL VERIFY ALL DIMENSIONS & CONDITIONS IN THE FIELD.

SHOP DRAWINGS SHALL BE SUBMITTED ACCORDING TO THE NJDOT SPECIFICATIONS.

BCD-8A

NEW JERSEY DEPARTMENT OF TRANSPORTATION

BRIDGE CONSTRUCTION DETAILS
BRIDGE CHAIN LINK FENCE
(CURVED TOP)

127
129

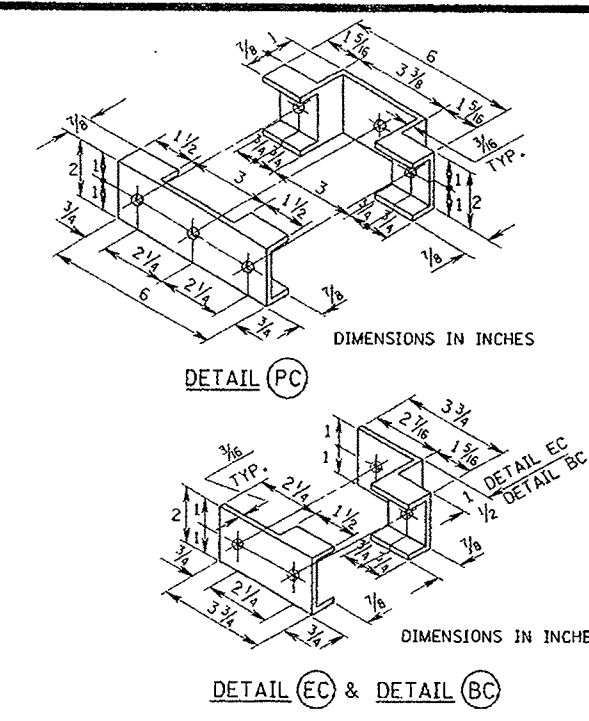
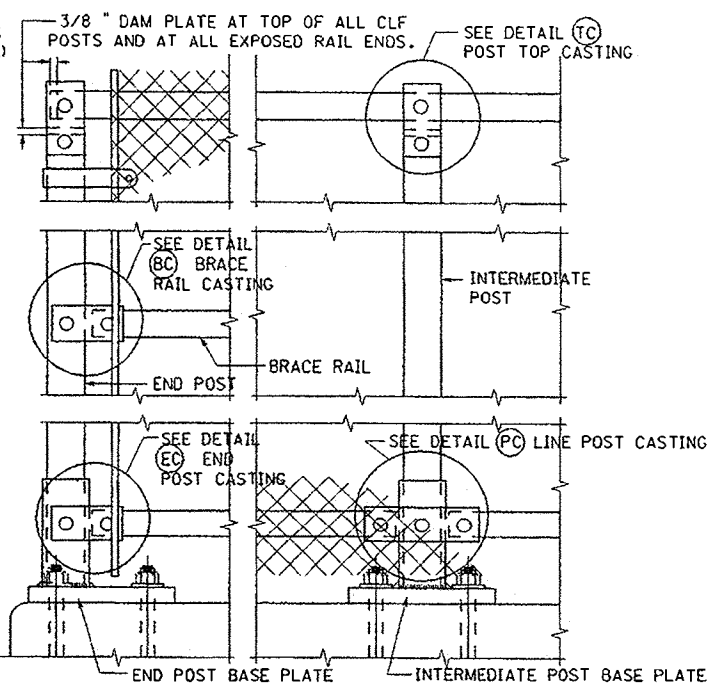
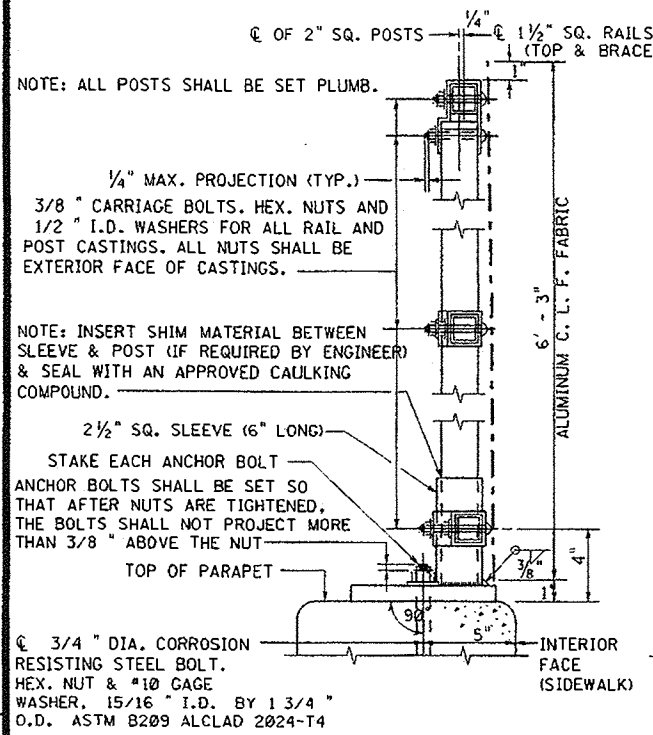

GENERAL NOTES:

DESIGN CRITERIA: "STANDARD SPECIFICATIONS FOR STRUCTURAL SUPPORTS FOR HIGHWAY SIGNS, LUMINAIRES AND TRAFFIC SIGNALS." AASHTO 1994 AND REVISIONS THERETO.

MAXIMUM DESIGN WIND VELOCITY: 80 MPH.

WIND PRESSURE DRAG COEFFICIENT FOR MESH FROM FIG. 1-13, "WIND LOAD ON SCREENS", NAVDOCKS DM-2; DESIGN MANUAL, STRUCTURAL ENGINEERING.

THE COMPONENT PARTS OF THE CHAIN LINK FENCING SHALL CONFORM TO THE MATERIAL REQUIREMENTS OF THE SPECIFICATIONS.

ANCHOR BOLTS SHALL BE ASTM A 276, TYPE 302. ANCHOR BOLTS SHALL BE SET BY THE CONTRACTOR WITH 2" OF CLEAR THREADS, SET CLEAN.

ALUMINUM SURFACES PLACED IN CONTACT WITH CONCRETE SHALL BE GIVEN A HEAVY COAT OF ALUMINUM PIGMENTED ALKALINE RESISTANT BITUMINOUS PAINT EQUAL TO FEDERAL SPECIFICATIONS TT-C-498C.

BASE PLATES FOR ALL CLF SHALL BE AS SHOWN, 3/8" THICK. (ALUMINUM ALLOY 6061-T6)

FILLET WELD MATERIAL SHALL BE FILLER ALLOY ER 5356 OR ER 5556.

POST SLEEVES SHALL BE 2 1/2" SQ., 7/8" WALL THICKNESS, ASTM B 221, AND SHALL BE WELDED TO BASE PLATE. (ALUMINUM ALLOY 6061-T6)

POSTS SHALL BE 2" SQ., 1/4" WALL THICKNESS, ASTM B 221, TO BE SET PLUMB AND SPACED AS SHOWN ON PLANS FOR EACH STRUCTURE. (ALUMINUM ALLOY 6061-T6)

SHIM MATERIAL SHALL BE USED WHERE NECESSARY FOR POST ALIGNMENT, ASTM B 209. (ALUMINUM ALLOY 1100-0)

ALL HORIZONTAL RAILS (TOP, BOTTOM, BRACE) SHALL BE 1 1/2" SQ., 1/8" WALL THICKNESS. (ALUMINUM ALLOY 6061-T6)

DAM PLATES, 3/8" THICK, WELDED TO CLOSE ALL EXPOSED ENDS OF RAIL TUBES AND TOP OF CHAIN LINK FENCE POSTS. (ALUMINUM ALLOY 6061-T6)

BRACE RAILS SHALL BE INSTALLED AT END UNITS WHERE CLF FABRIC IS TENSIONED.

RAILING EXPANSION SLEEVES SHALL BE 2" SQ. X 7" LONG, WITH HOT-DIP GALVANIZED SPRING IN SLEEVE, SPRING NOT TO EXCEED 1 1/2" FULLY COMPRESSED. RAIL ENDS TO BE 3" APART IN SLEEVE AT 1/2" SLEEVE "V" CRIMP, (ALUMINUM ALLOY 6061-T6) ASTM B 221.

STRETCHER BARS TO BE 1/4" X 3/8". (ALUMINUM ALLOY 6061-T6)

STRETCHER BAR BANDS TO BE 1/8" X 1" BEVELLED EDGES. (ALUMINUM ALLOY 6063-T6)

FABRIC TIES SHALL BE #9 GAGE (0.148" DIA.), A MINIMUM OF ONE (1) COMPLETE TURN IS REQUIRED AT ENDS OF ALL TIES. (ALUMINUM ALLOY 6061-T6)

CLF FABRIC SHALL BE #9 GAGE (0.148" DIA.) HAVING A 1" DIAMOND MESH, TOP AND BOTTOM SELVAGE TO BE KNUCKLED. FABRIC SHALL BE CONTINUOUS ACROSS ALL JOINTS.

STRETCHER BAR BAND FASTENERS TO BE 3/8" DIA. BY 1/4" CARRIAGE BOLTS. (ALUMINUM ALLOY 2024-T4)

STAKE EACH ANCHOR BOLT AT ONE (1) POINT ONLY.

ALL HOLES IN CASTINGS SHALL BE 7/8" DIA. CASTINGS SHALL BE ALUMINUM TENZALY ALLOY ZC81A, CONDITION T5. ALL CASTINGS SHALL BE DESIGNED TO ACCOMMODATE RAILS AT GRADES AS REQUIRED.

AFTER ERECTION, ALL ANCHOR BOLT HOLES & SPACES BETWEEN BASE PLATES & CONCRETE SHALL BE THOROUGHLY CAULKED WITH AN ALUMINUM IMPREGNATED CAULKING COMPOUND CONFORMING TO FEDERAL SPECIFICATIONS TT-C-5988(2).

AFTER ERECTION OF POSTS, DRILL 3/8" DIA. HOLE THROUGH POST SLEEVE AND POST, 1/2" ABOVE BASE PLATE FOR DRAINAGE. LOCATE HOLE PARALLEL TO FENCING.

THE CONTRACTOR SHALL VERIFY ALL DIMENSIONS & CONDITIONS IN THE FIELD.

SHOP DRAWINGS SHALL BE SUBMITTED ACCORDING TO THE NJDOT SPECIFICATIONS.

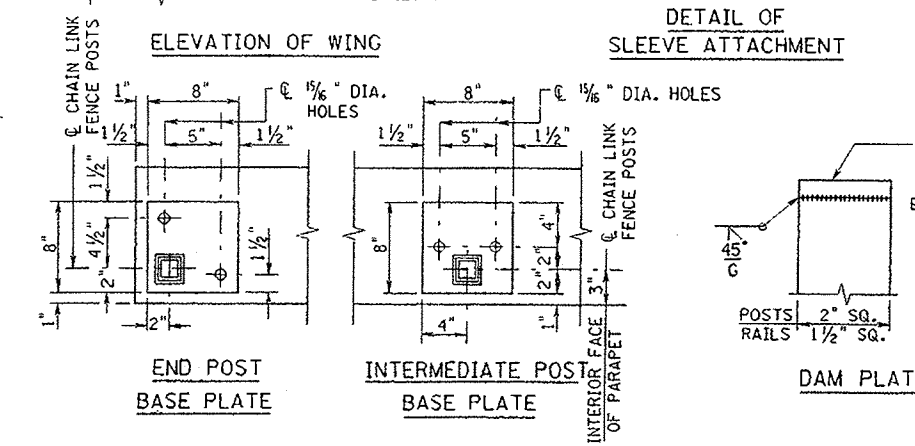
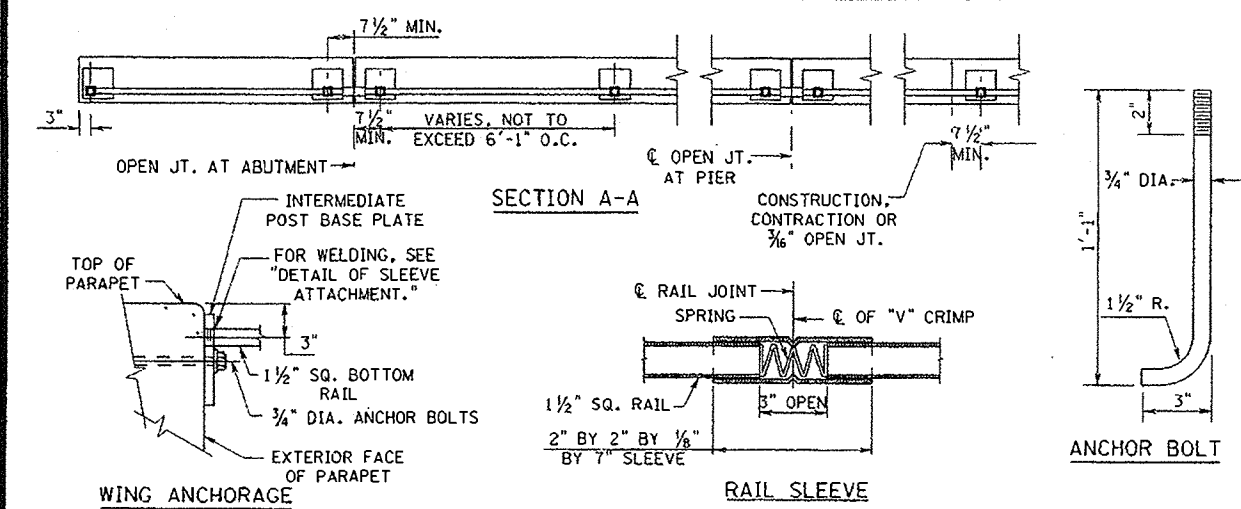
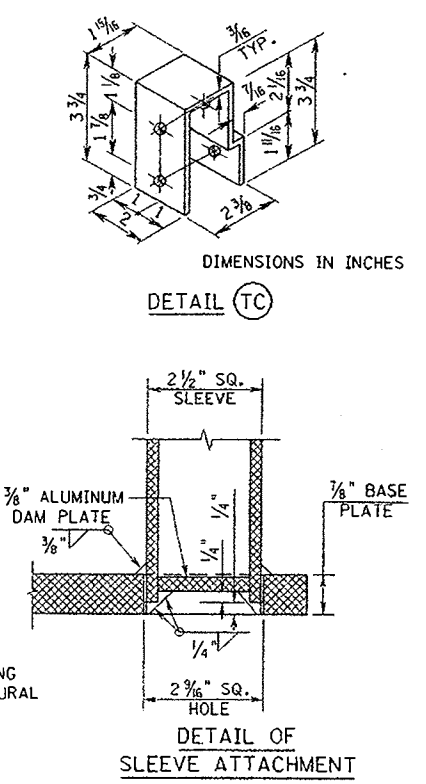
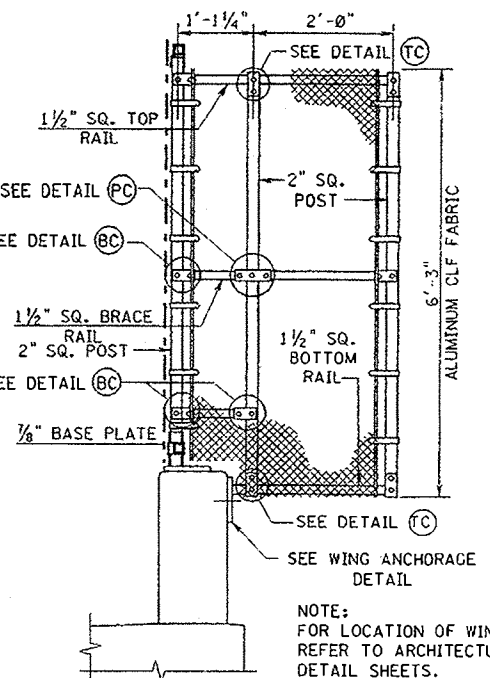
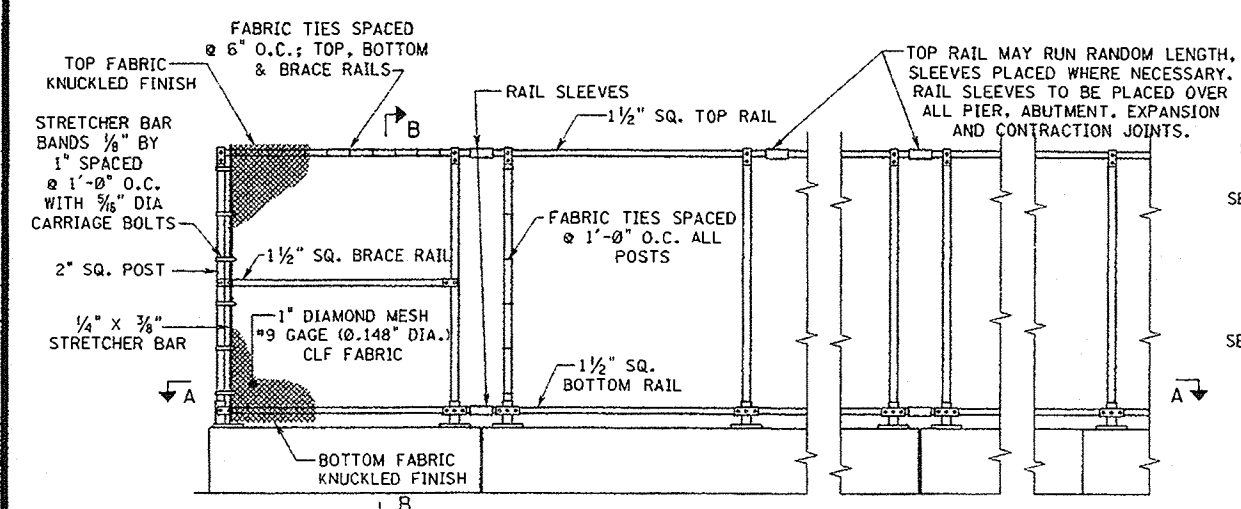

BCD-88

NEW JERSEY DEPARTMENT OF TRANSPORTATION

BRIDGE CONSTRUCTION DETAILS
BRIDGE CHAIN LINK FENCE
(6' - 3" HIGH)

128
129

S-I-P FORMS BETWEEN STRINGERS
VARIABLE SLAB ELEVATION
NORMAL L SUPPORTS

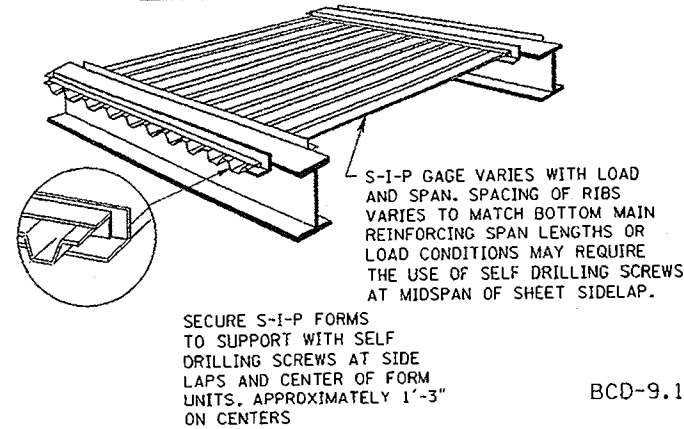
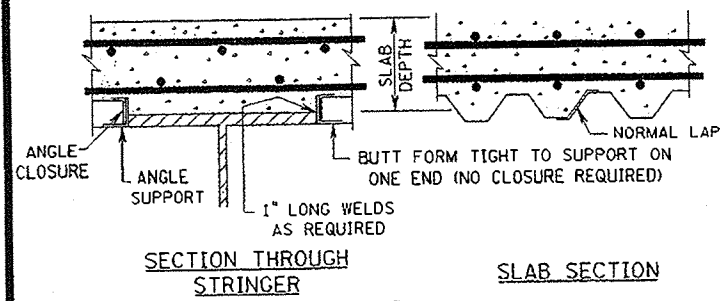

BCD-9.1

S-I-P FORMS BETWEEN STRINGERS
VARIABLE SLAB ELEVATION
INVERTED L SUPPORTS

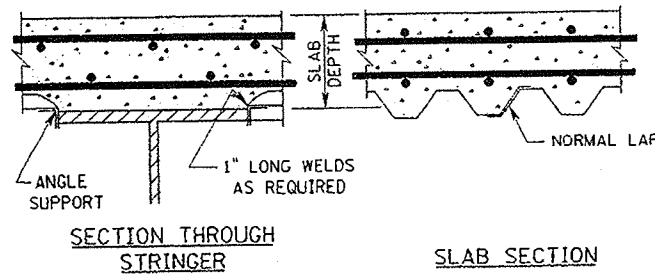

SPAN LENGTHS OR LOAD CONDITIONS MAY REQUIRE THE USE OF SELF DRILLING SCREWS AT MIDSPAN OF SHEET SIDELAP.

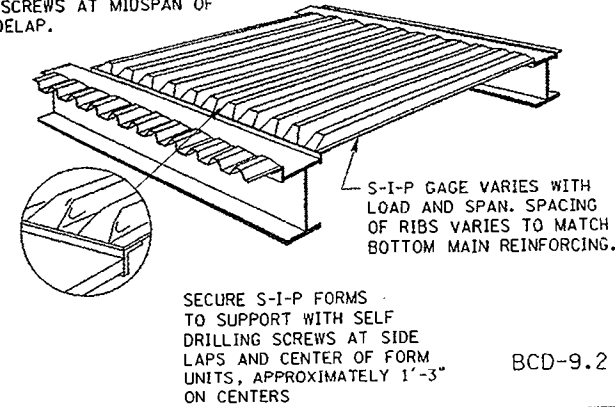

BCD-9.2

S-I-P FORMS
WITH ADJUSTABLE SUPPORTS
NOT WELDED TO STRINGERS
(TO BE USED IN THE TENSION ZONE OF CONTINUOUS SPAN BRIDGES)

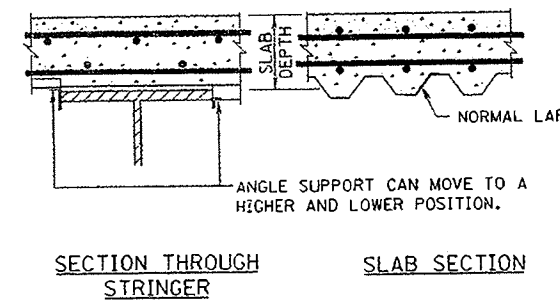

1/4" x 1/4" ANGLE FIELD CUT TO FIT. SPACED AND WELDED AS REQUIRED.

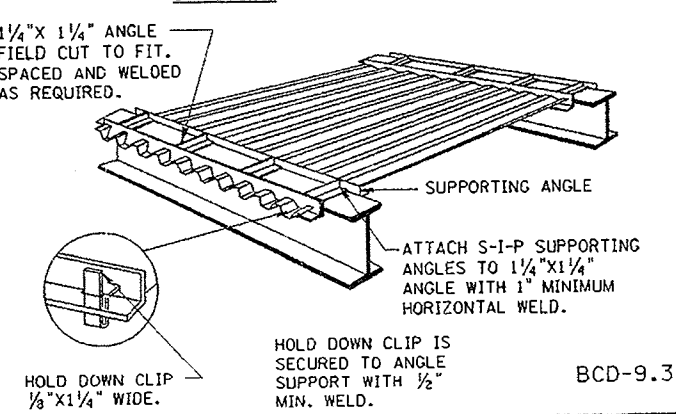

BCD-9.3

S-I-P FORMS
WITH ADJUSTABLE L SUPPORTS
STRINGER FLANGE ENCASEMENT PROVIDED

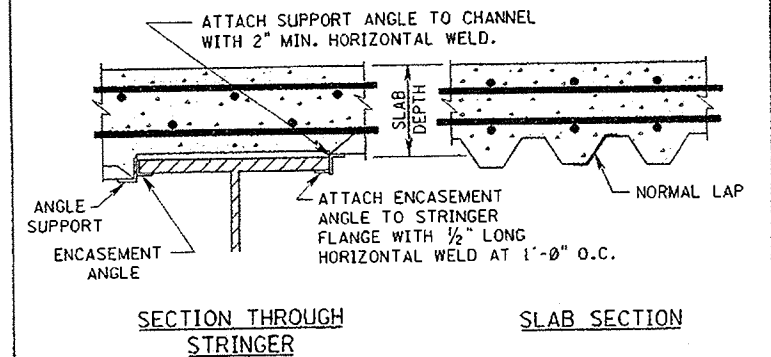

1/4" x 2 1/2" x 1/4" CHANNEL SHOP CUT TO LENGTH SPACED AS REQUIRED.

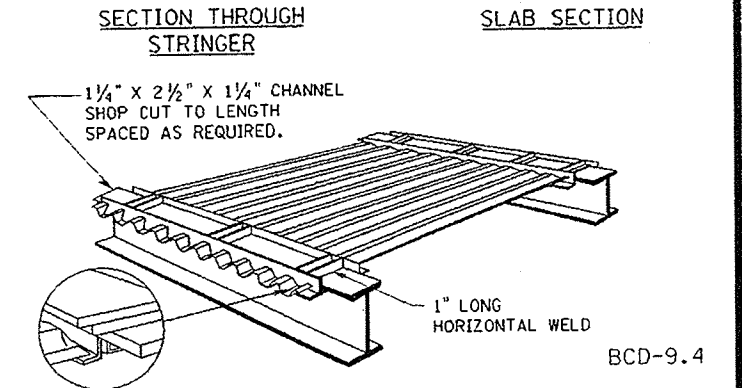

BCD-9.4

S-I-P FORMS BETWEEN PRECAST CONCRETE STRINGERS

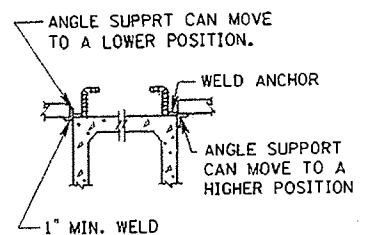
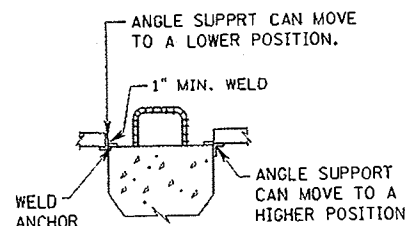
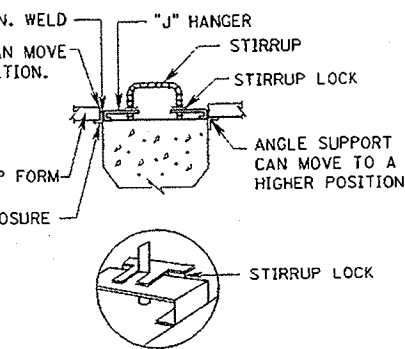
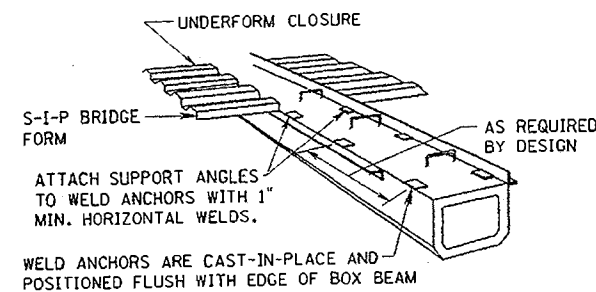
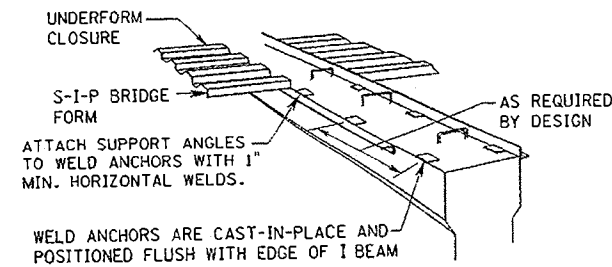
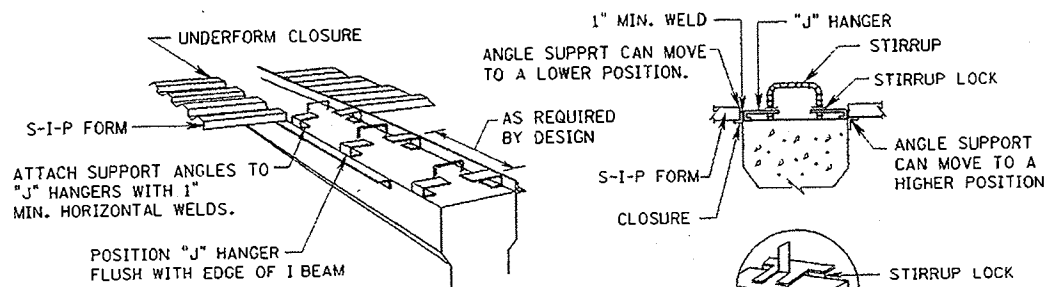

BCD-9.5

NOTE:

THE CONTRACTOR SHALL SURVEY THE TOP OF BEAM ELEVATIONS AS REQUIRED TO ESTABLISH HAUNCH DIMENSIONS X AND Y AND CUT-OFF DIMENSION Z.

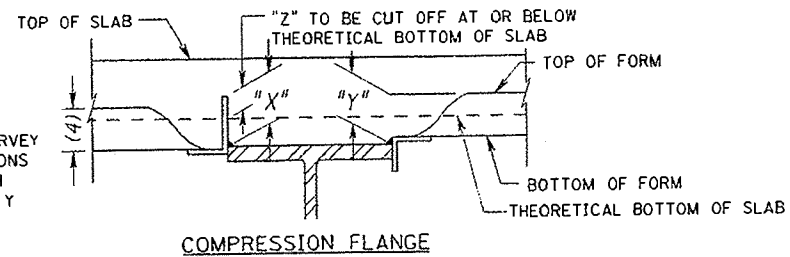

THE ABOVE SKETCH AND NOTE SHALL APPEAR ON THE SHOP PLANS FOR STAY-IN-PLACE DECK FORMS SUBMITTED BY THE FABRICATOR. ANY SHOP DRAWING SUBMITTED WITHOUT THE SKETCH AND NOTE SHALL BE RETURNED FOR REVISION AND RESUBMISSION.

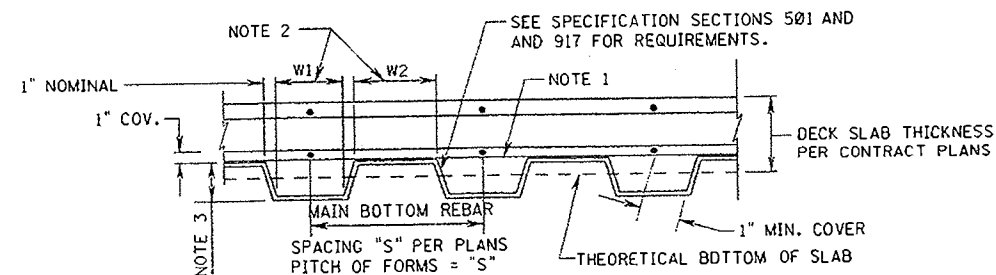

GENERALLY, THE SPACING (PITCH) OF RIBS (FLUTES) SHALL MATCH SPACING OF BOTTOM MAIN REINFORCEMENT STEEL AND BOTTOM MAIN REBARS SHALL BE PLACED AT THE CENTER OF EACH RIB TO PROVIDE MAXIMUM CONCRETE COVER. OCCASIONALLY, THE DECK FORMS MUST BE DROPPED WHEN RIBS AND BOTTOM MAIN REBARS CAN NOT BE ALIGNED. REFER TO THE ALTERNATE BELOW FOR MORE DETAILS ON THIS CONDITION.

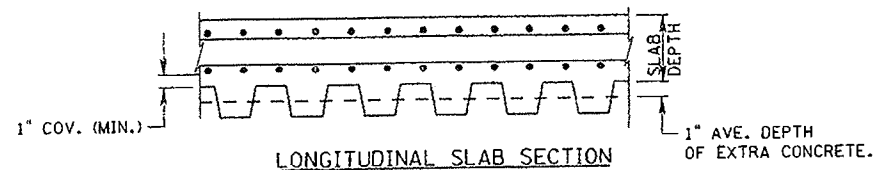

NOTES:

- 1/2" CORROSION PROTECTED STEEL BARS MAY BE USED AS REBAR SUPPORTS.
- W1 SHALL BE EQUAL TO OR LESS THAN W2.
- RIBS ARE ASSUMED TO BE 2" DEEP. SPECIAL DESIGN CONSIDERATIONS ARE REQUIRED FOR DEEPER FORMS.

BCD-9.6

GENERAL NOTE:

THE DETAILS SHOWN ARE GENERAL. SHOP DRAWINGS ACCORDING TO THE NJDOT SPECIFICATIONS SHALL BE SUBMITTED FOR ACTUAL DETAILS.

NEW JERSEY DEPARTMENT OF TRANSPORTATION

BRIDGE CONSTRUCTION DETAILS
STAY-IN-PLACE FORMS

BCD-9

129